

SCALE :

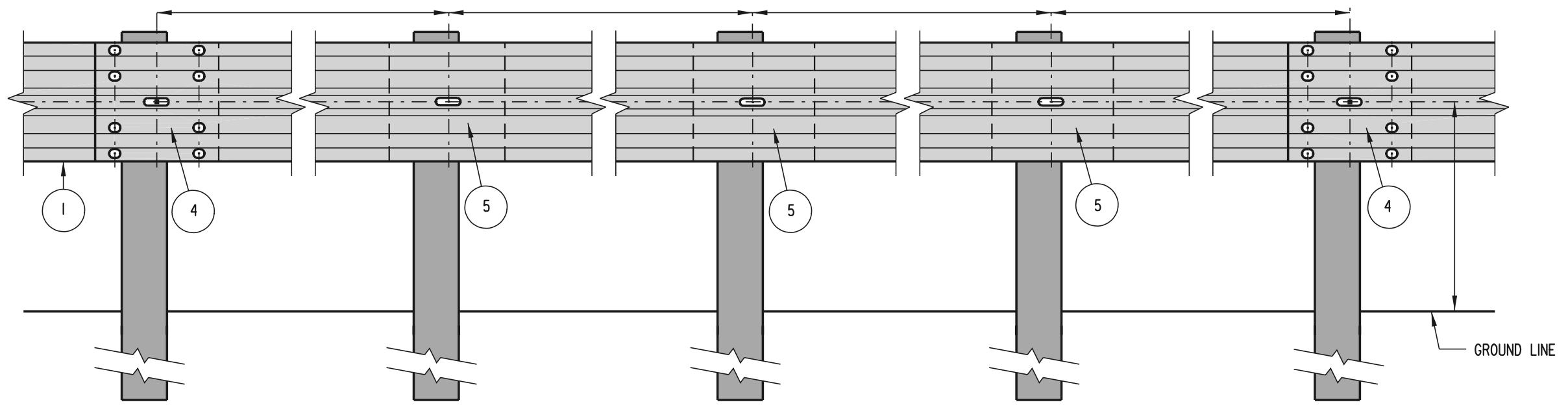

**TYPE 2**

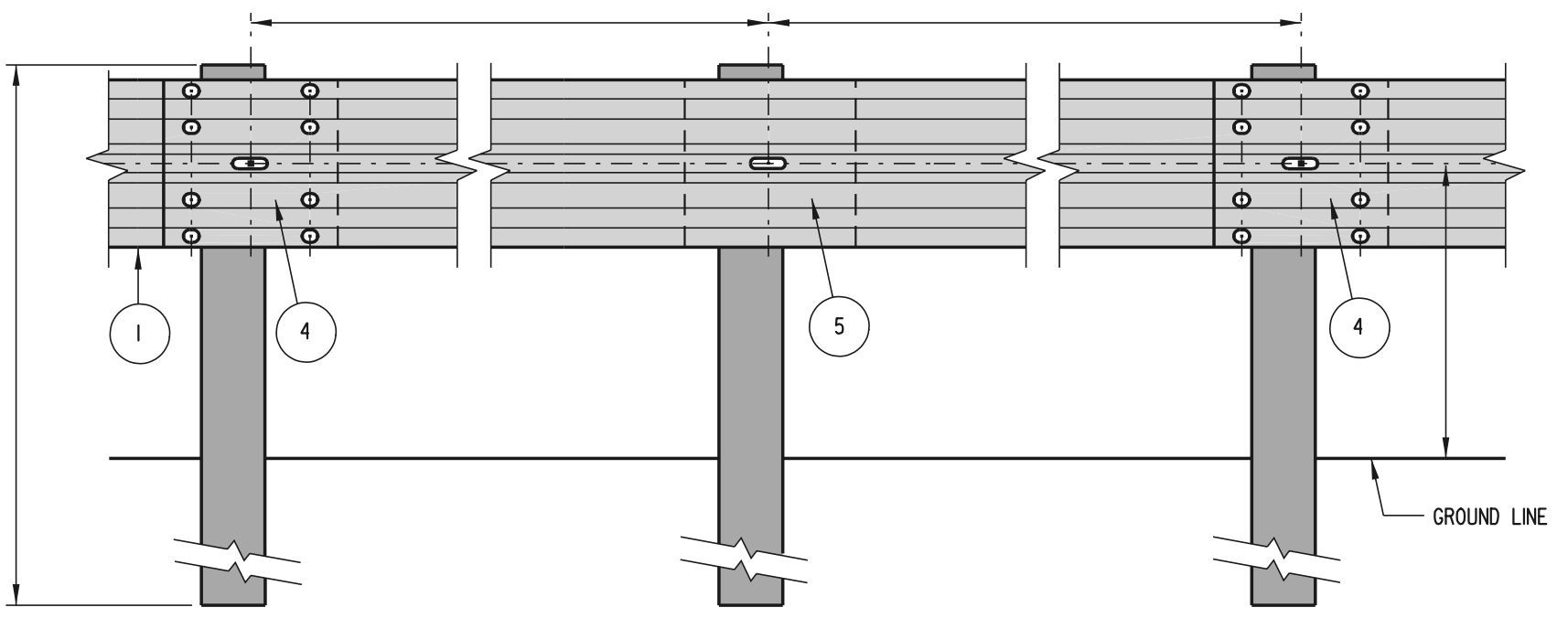
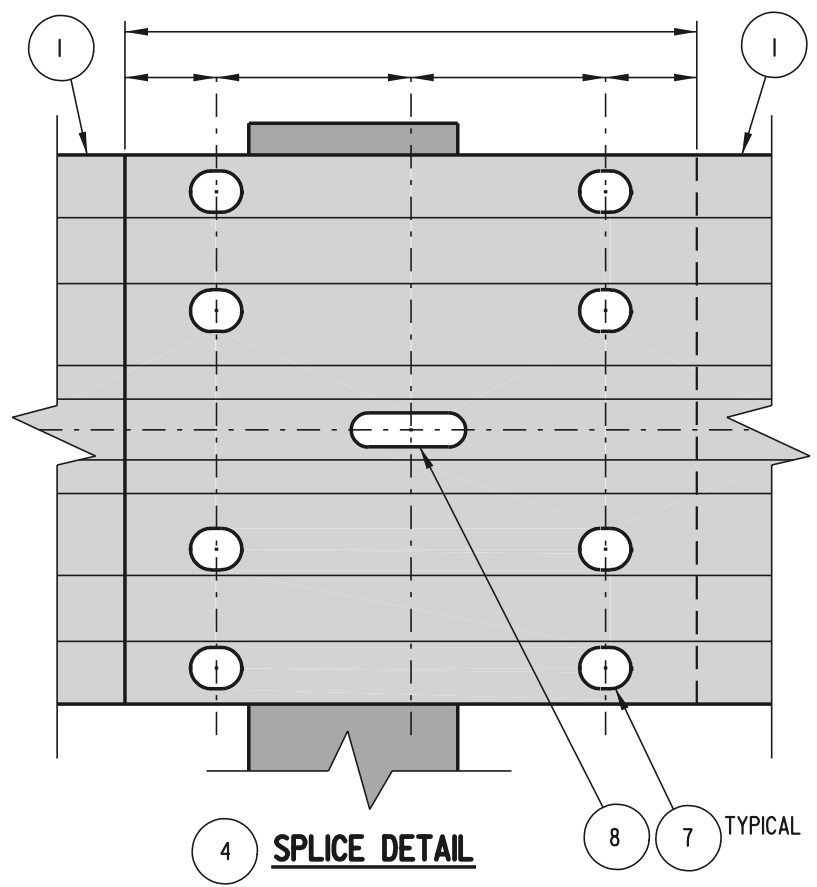

**TYPE 1 OR 3**

NOTES : 1). OVERLAP W-BEAMS IN DIRECTION OF TRAVEL.  
2). PLACE REFLECTORIZED WASHER EVERY FIFTH POST.