

SCALE :

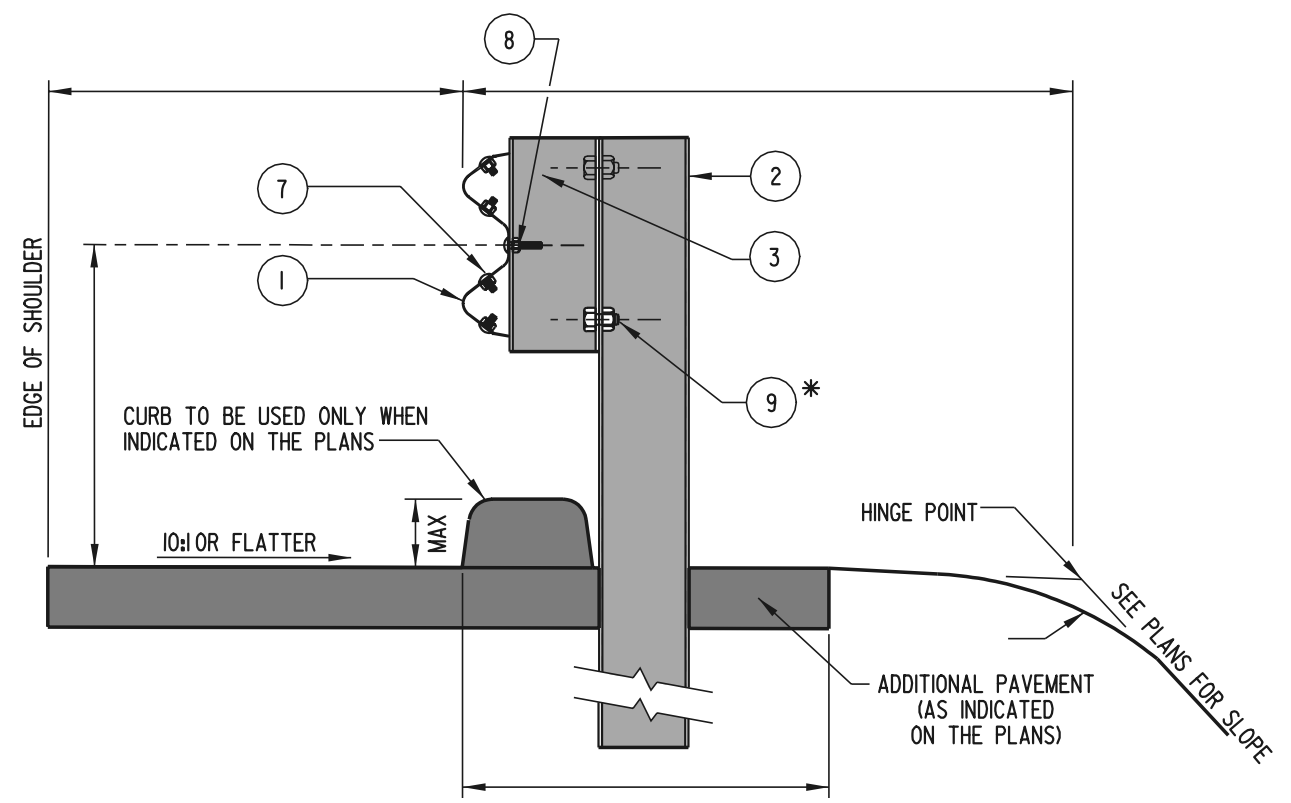

GUARDRAIL SECTION
(RURAL SHOULDER APPLICATION)

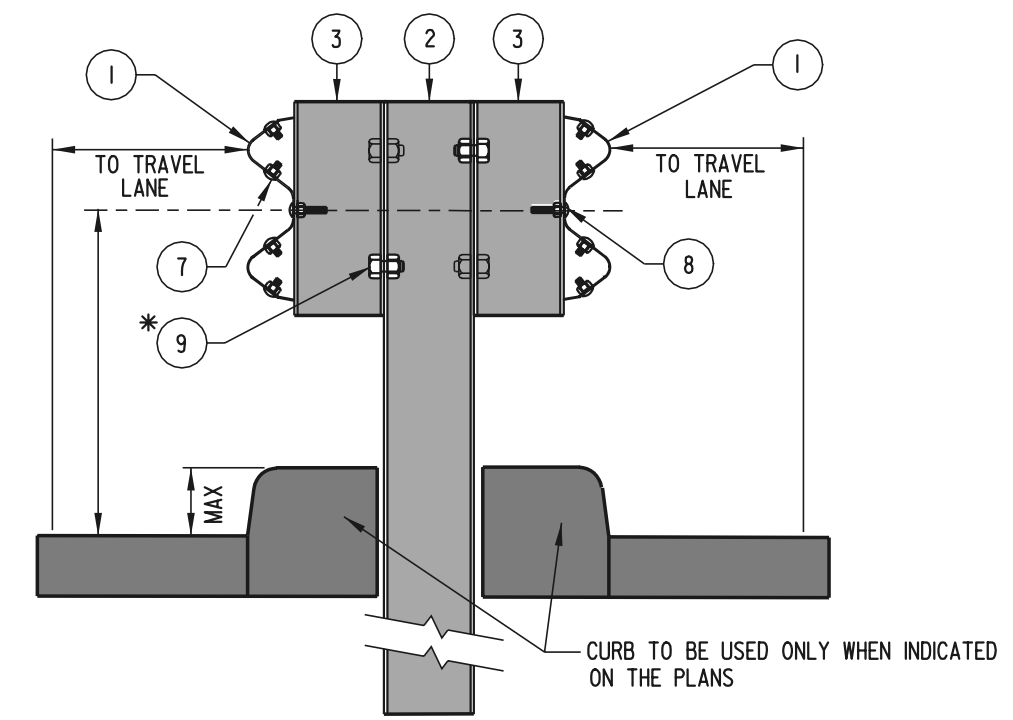

GUARDRAIL SECTION
(MEDIAN APPLICATION)

* USE TWO BOLTS TO CONNECT OFFSET BLOCKS TO POSTS - PLACED DIAGONALLY, ONE ON EACH SIDE OF FLANGE.

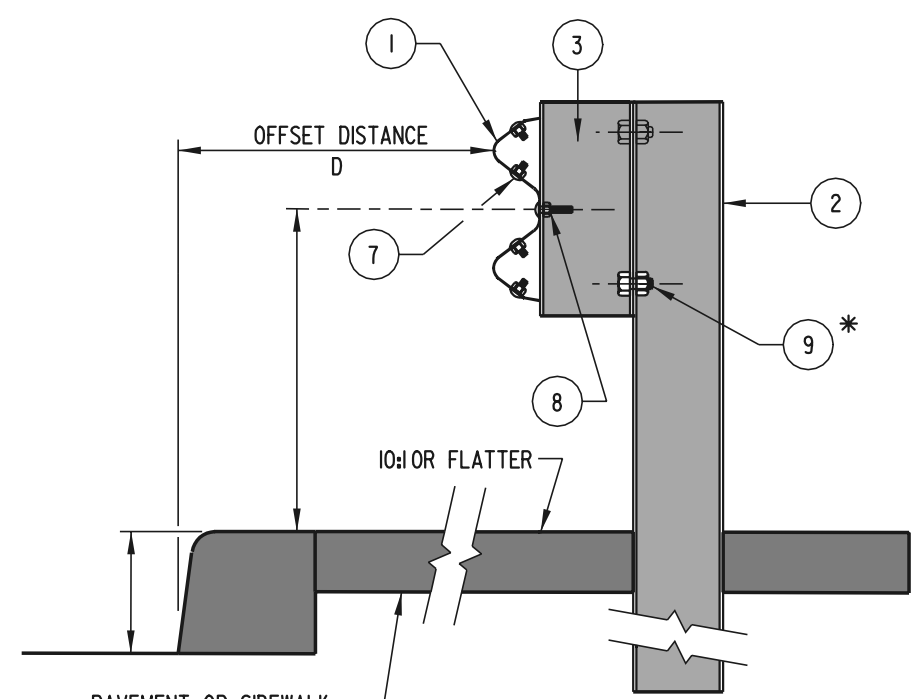

GUARDRAIL SECTION
(URBAN SHOULDER APPLICATION)

DESIGN SPEED (km/h)	