

SCALE :

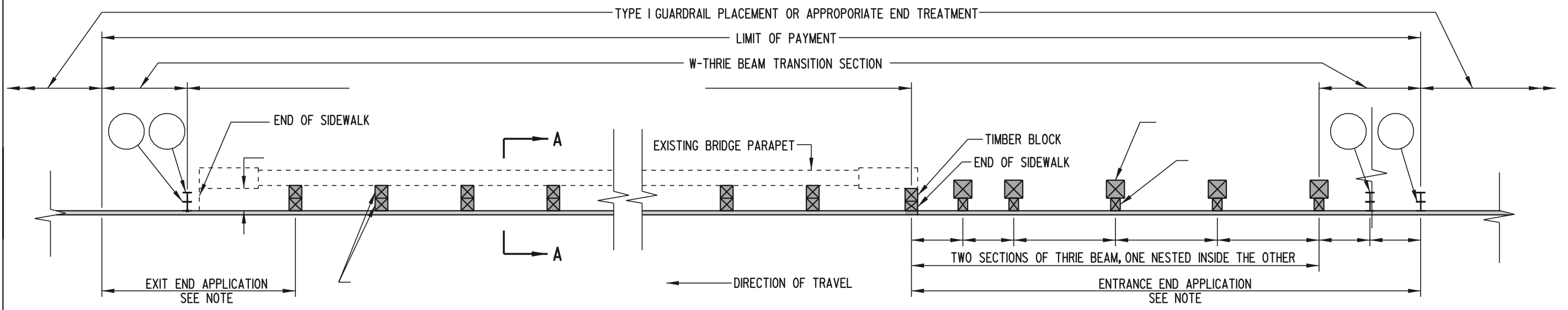

**PLAN**

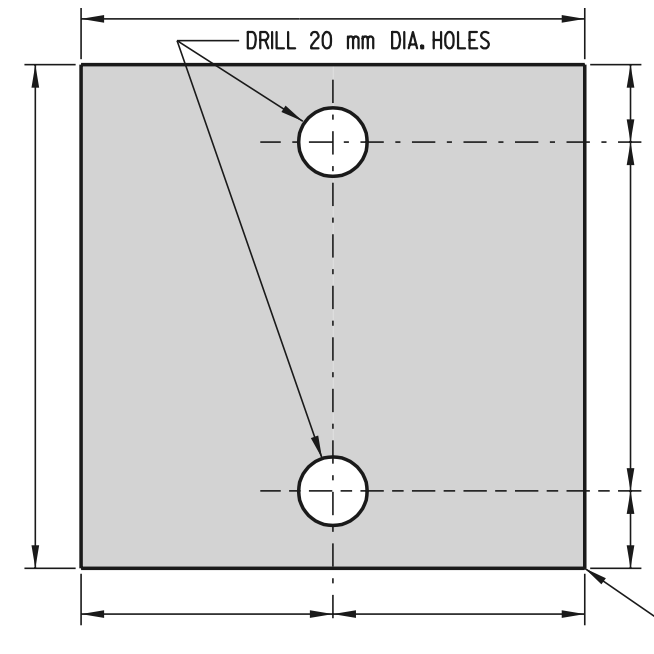

**THRIE BEAM BEARING PLATE DETAIL**

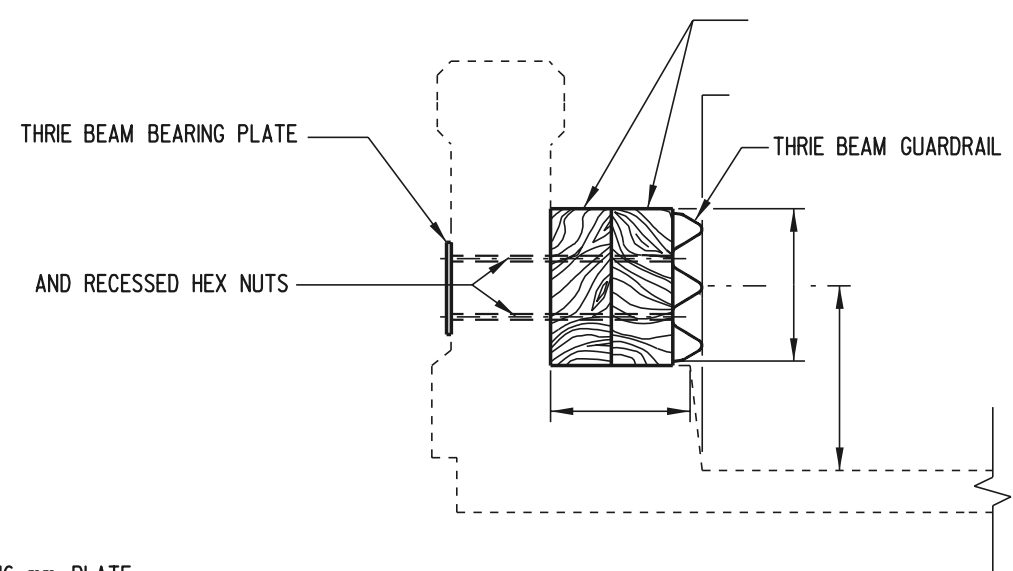

**SECTION A-A**

- NOTES:**
- 1). THIS INSTALLATION SHALL BE USED WHEN THE EXISTING SIDEWALK IS 450 mm OR LESS.
  - 2). USE A THRIE BEAM EXPANSION SECTION AT BRIDGE EXPANSION JOINTS.
  - 3). POSTS ARE SPACED AT 1905 mm CENTER TO CENTER, UNLESS NOTED.
  - 4). PLACE REFLECTORIZED WASHER IN THE UPPER VALLEY OF THE THRIE BEAM EVERY FIFTH POST.
  - 5). TIMBER BLOCK THICKNESS SHALL BE ADJUSTED TO ALLOW FACE OF THE THRIE BEAM TO BE FLUSH WITH BOTTOM OF CURB
  - 6). THE EXIT END APPLICATION SHALL BE USED ONLY ON DIVIDED HIGHWAYS. FOR ALL OTHER SITUATIONS, THE ENTRANCE END
  - 7). SPACING OF WOOD POSTS MAY NEED TO BE REDUCED TO ACCOMMODATE LINING UP POSTS AT THE END OF THE PARAPET.