

SCALE : N.T.S.

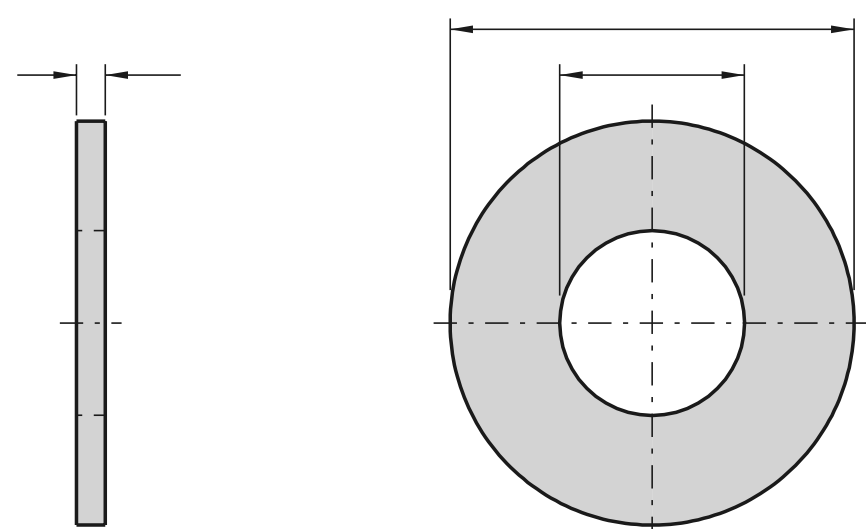

**STEEL WASHER**

NOTES : 1. FOR USE WITH SWAGED CABLE ASSEMBLAGE.  
2. DIMENSION FOR WASHER THICKNESS IS APPROXIMATE BASE METAL THICKNESS.

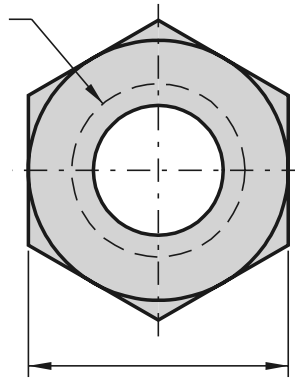
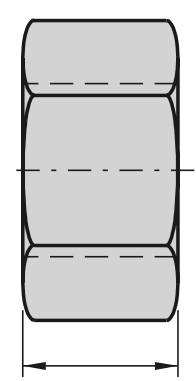
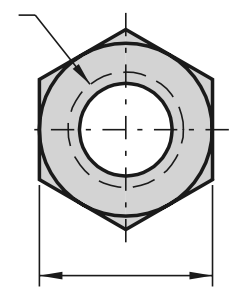
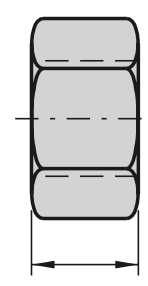
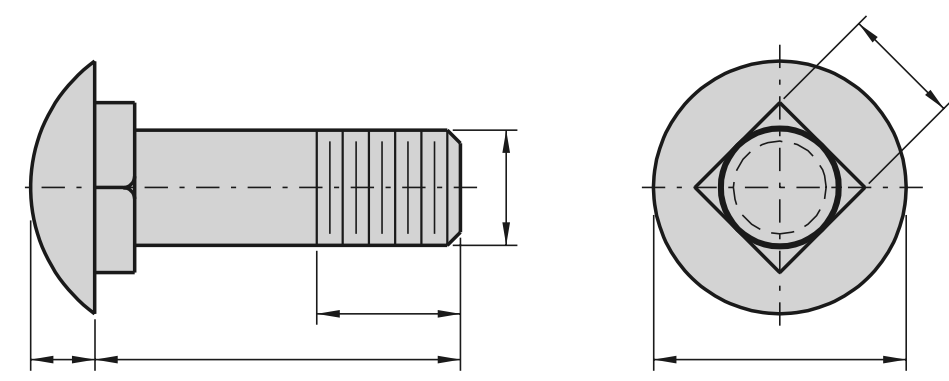

NOTE : FOR USE WITH SWAGED CABLE ASSEMBLAGE.

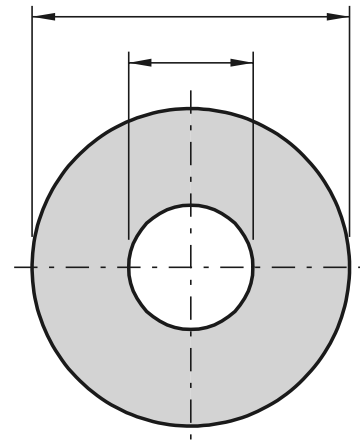
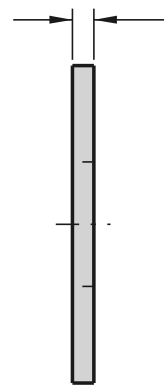

NOTE : DIMENSION FOR WASHER THICKNESS IS APPROXIMATE BASE METAL THICKNESS.



**DELAWARE**  
**DEPARTMENT OF TRANSPORTATION**

**HARDWARE**

STANDARD NO. **B-13 (97)**

SHT. **12** OF **12**

**APPROVED**

CHIEF ENGINEER \_\_\_\_\_ DATE \_\_\_\_\_

**RECOMMENDED**

DESIGN ENGINEER \_\_\_\_\_ DATE \_\_\_\_\_