

SCALE : N.T.S.

MIN. * OUTFALL PIPE DIA. (mm)	MIN. RISER DIA. (mm)	MAX. DRAINAGE AREA (ha)

* OUTFALL PIPE DIAMETER MAY BE SAME SIZE AS RISER DIAMETER.

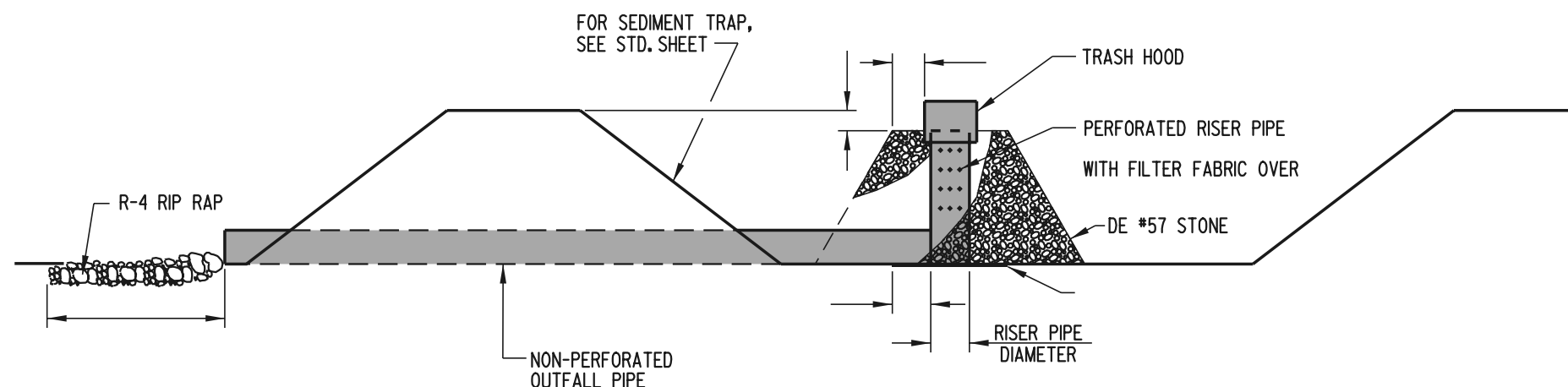

ELEVATION

- NOTES:**
- 1). THIS DEVICE IS INTENDED TO BE USED AS AN OUTLET FOR SEDIMENT TRAPS.
 - 2). PERFORATIONS SHALL BE 25 mm IN DIAMETER, LOCATED HORIZONTALLY AND VERTICALLY, AND SHALL NOT THE OUTFALL PIPE.
 - 3). THE PIPE OUTLET SHOWN SHALL ONLY BE USED WITH SEDIMENT TRAPS WITH DRAINAGE AREAS OF REQUIRE AN ENGINEERED DESIGN.

PLAN SYMBOL



**DELAWARE
DEPARTMENT OF TRANSPORTATION**

SEDIMENT TRAP, USING RISER PIPE AS OUTLET

STANDARD NO. E-8 (97)

SHT. 1 OF 2

APPROVED

CHIEF ENGINEER _____ DATE _____

RECOMMENDED

DESIGN ENGINEER _____ DATE _____