

SCALE :

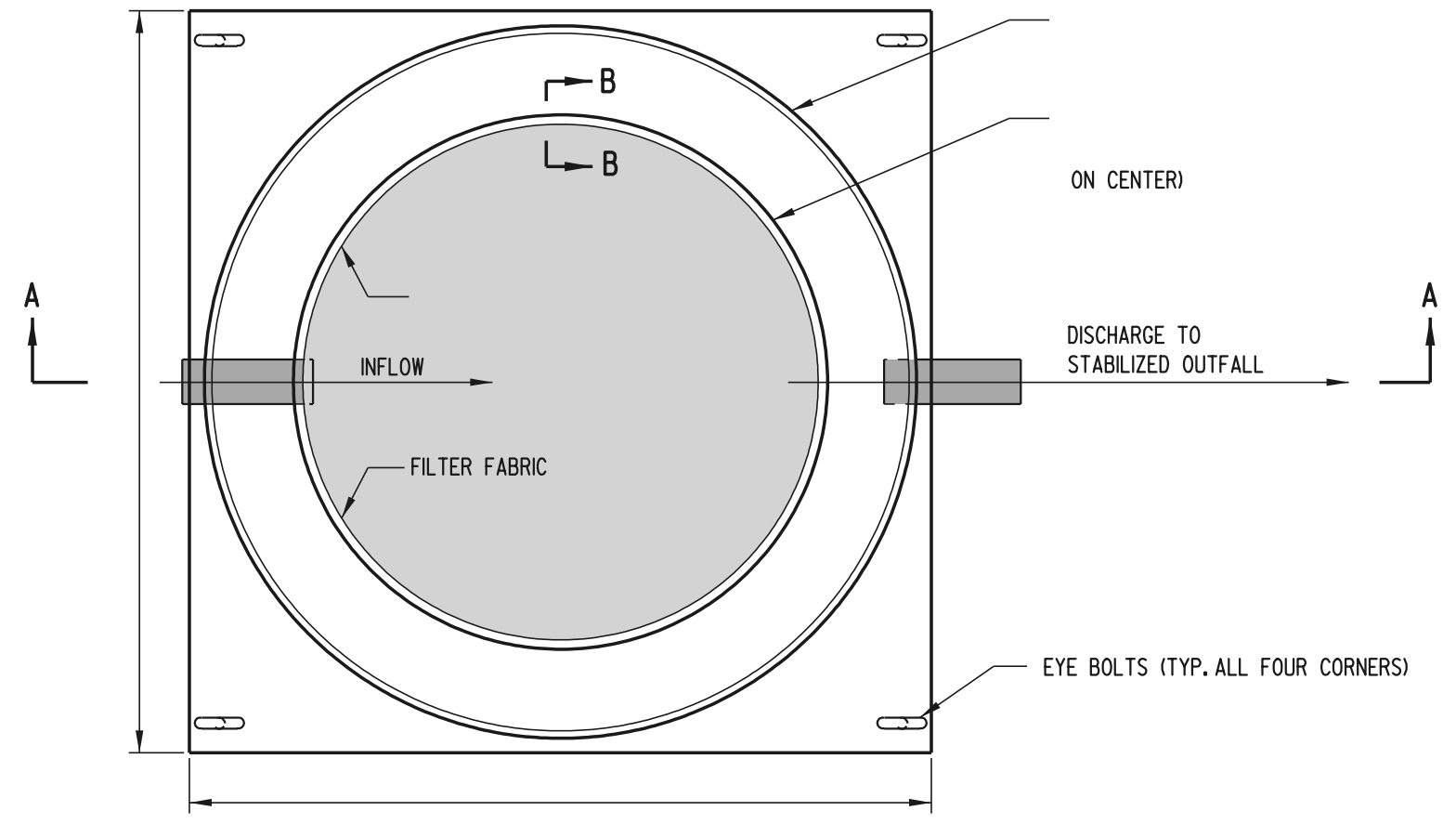

PLAN

- NOTES:**
- 1). THE PORTABLE SEDIMENT TANK SHOWN MAY BE USED IN SITES WHERE SPACE IS LIMITED TO CONSTRUCT A DEWATERING BASIN.
 - 2). THE MAXIMUM PUMP DISCHARGE INTO THIS TYPICAL PORTABLE SEDIMENT TANK SHALL BE
 - 3). SEVERAL UN-CONNECTED OR CONNECTED IN PARALLEL PORTABLE SEDIMENT TANKS MAY BE USED WHEN A HIGHER FLOW RATE IS NEEDED TO DE-WATER THE JOB.
 - 4). OTHER DESIGNS MAY BE USED PROVIDED THE HYDRAULIC DESIGN IS SUBMITTED TO AND APPROVED BY THE STORMWATER ENGINEER.

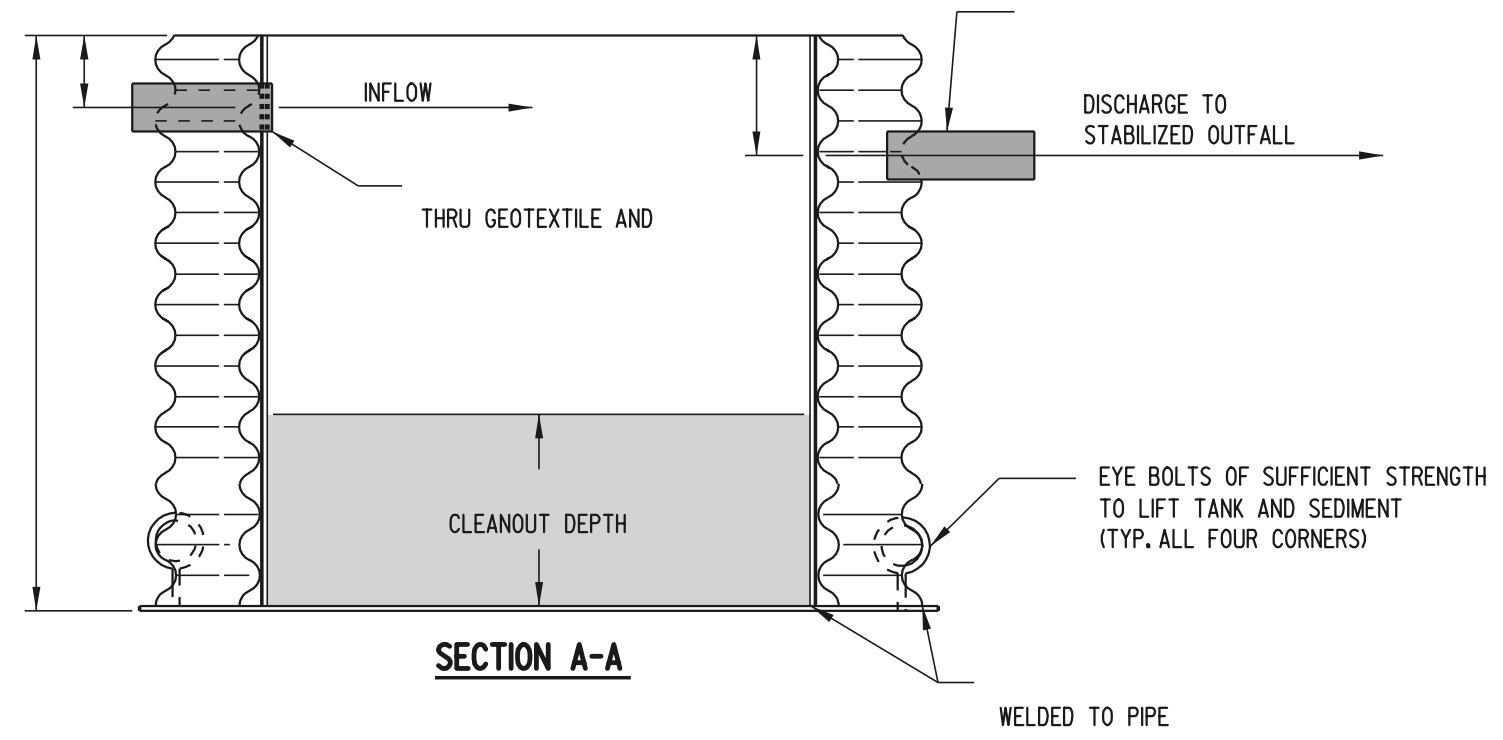

SECTION A-A

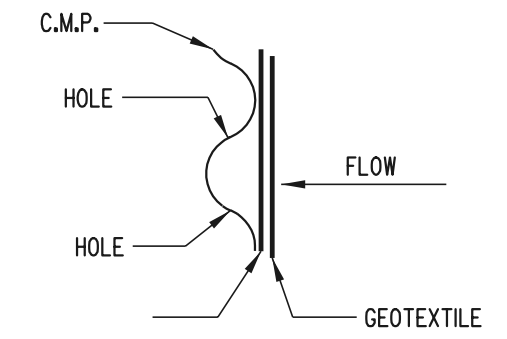

SECTION B-B

PLAN SYMBOL



 DELAWARE DEPARTMENT OF TRANSPORTATION	PORTABLE SEDIMENT TANK			APPROVED
	STANDARD NO. E-24 (99)	SHT. 1	OF 1	<small>CHIEF ENGINEER</small> _____ <small>DATE</small> _____ RECOMMENDED <small>DESIGN ENGINEER</small> _____ <small>DATE</small> _____