

SCALE :

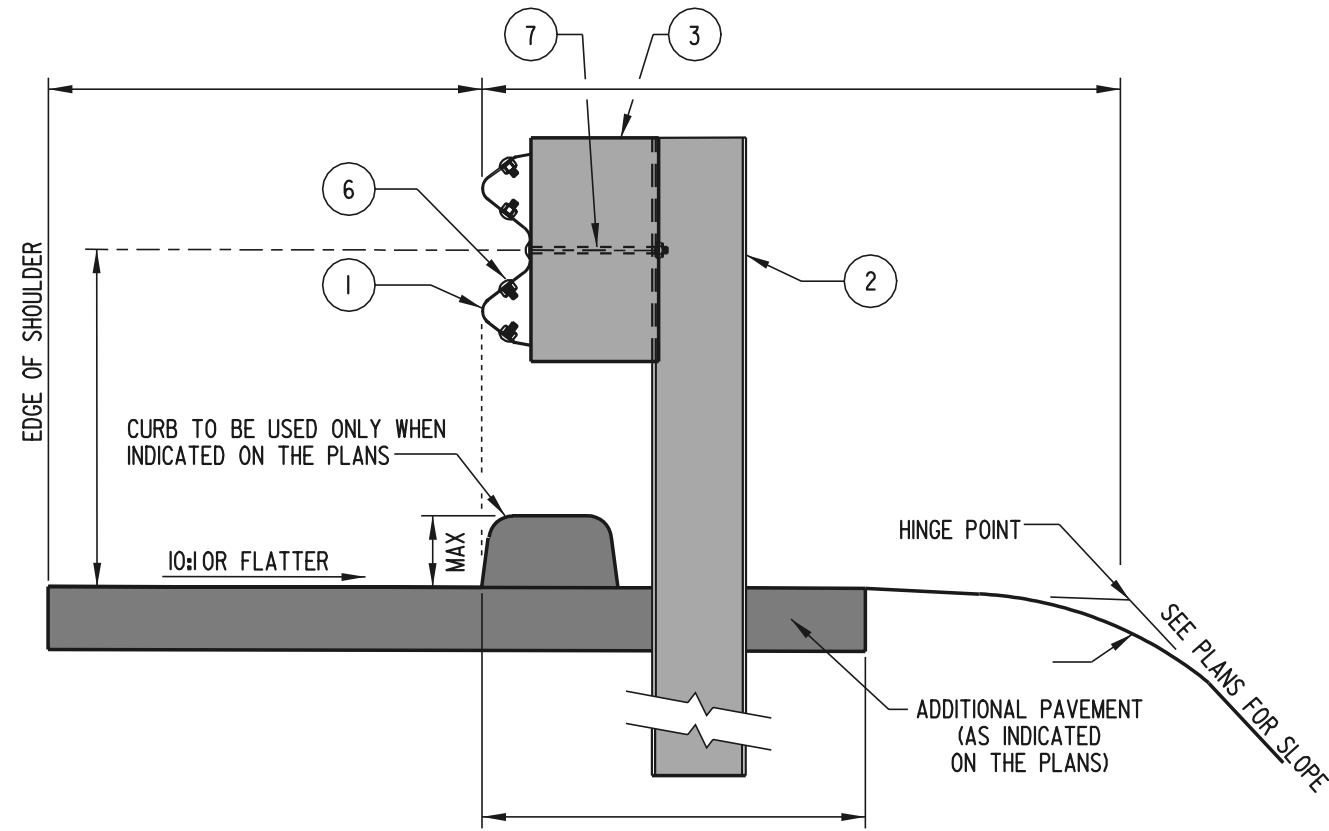

GUARDRAIL SECTION
(RURAL SHOULDER APPLICATION)

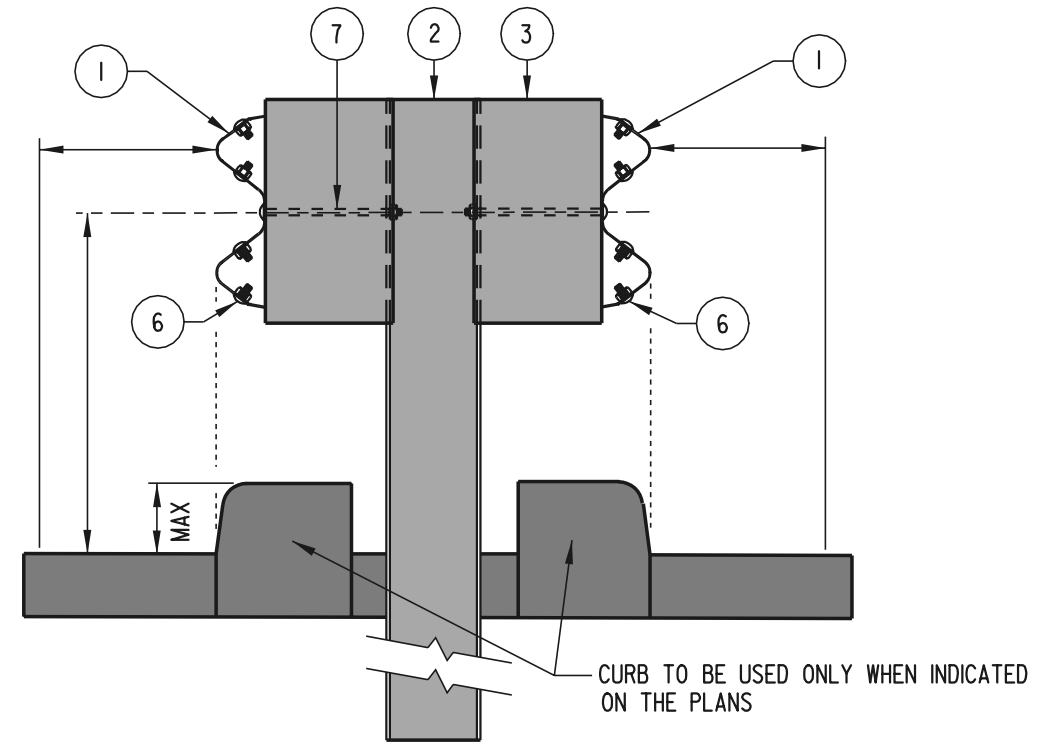

GUARDRAIL SECTION
(MEDIAN APPLICATION)

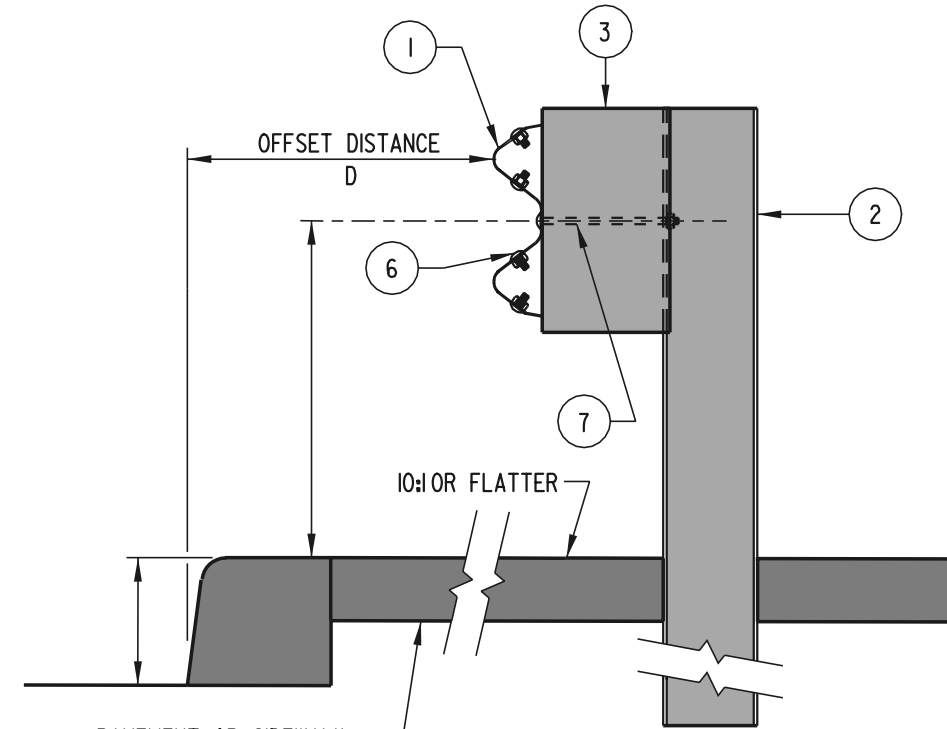

GUARDRAIL SECTION
(URBAN SHOULDER APPLICATION)

DESIGN SPEED (km/h)	



DELAWARE
DEPARTMENT OF TRANSPORTATION

GUARDRAIL APPLICATIONS

STANDARD NO. **B-1 (2000)**

SHT. **3** OF **3**

APPROVED

CHIEF ENGINEER DATE

RECOMMENDED

DESIGN ENGINEER DATE