

**RECESSED NUT
(FOR 5/8" (16) GAURDRAIL BOLT)**

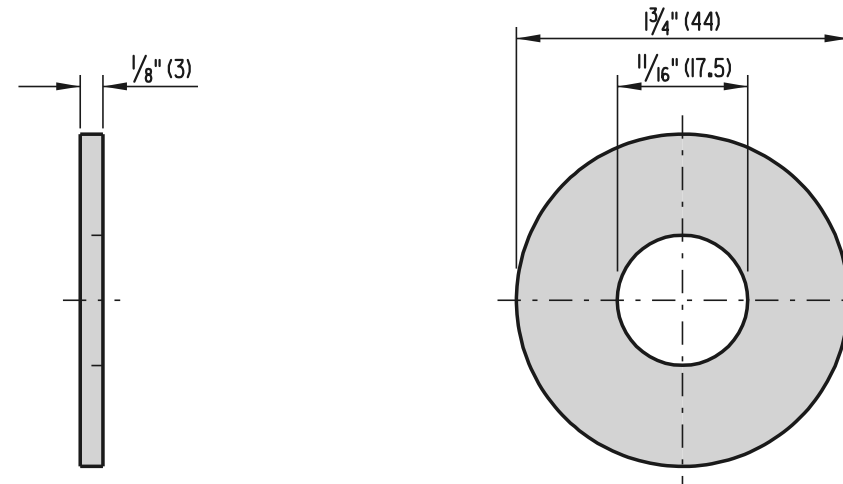

STEEL WASHER (FOR 5/8" (16) GUARDRAIL BOLT)

NOTE : DIMENSION FOR WASHER THICKNESS IS APPROXIMATE BASE METAL THICKNESS.

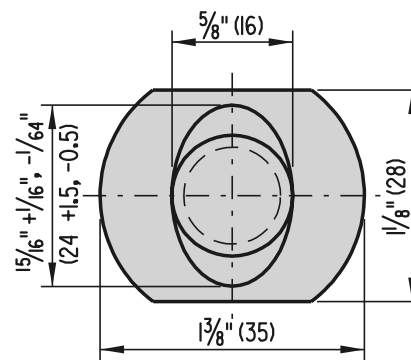
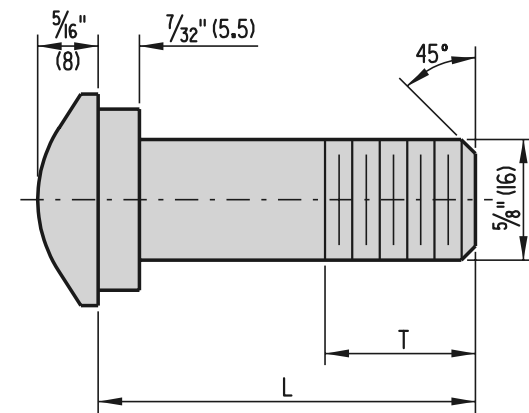

GUARDRAIL BOLT

L	T (MIN.)
1/4" (35)	FULL THREAD LENGTH
2" (50)	FULL THREAD LENGTH
10" (255)	4" (100) THREAD LENGTH
18" (460)	4" (100) THREAD LENGTH

NOTES : 1. ALL FILLETS SHALL HAVE A MINIMUM RADIUS OF 1/16" (2).
2. IF THE BOLT EXTENDS MORE THAN 1/4" (6) FROM THE NUT, THE BOLT SHOULD BE TRIMMED BACK.



DELAWARE
DEPARTMENT OF TRANSPORTATION

HARDWARE

STANDARD NO. B-13 (2001)

SHT. 10 OF 12

APPROVED *Ryan M. Harkins* 6/18/01
CHIEF ENGINEER DATE
 RECOMMENDED *Mehal Akhavan* 6/18/01
DESIGN ENGINEER DATE