

**VERTICAL TRANSLATION**

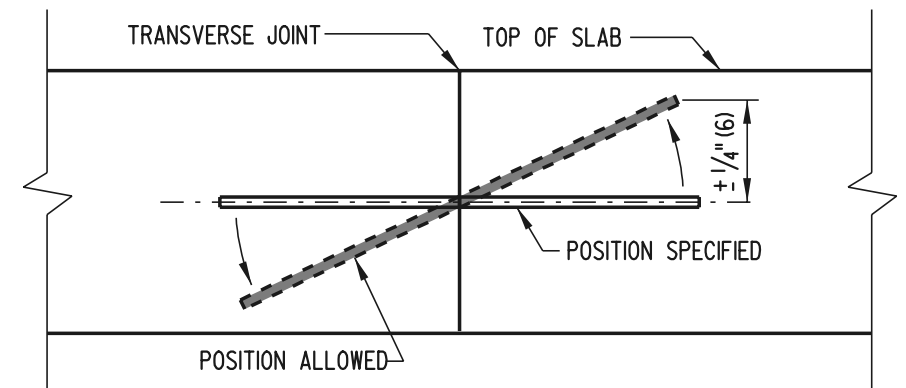

**VERTICAL ROTATION**

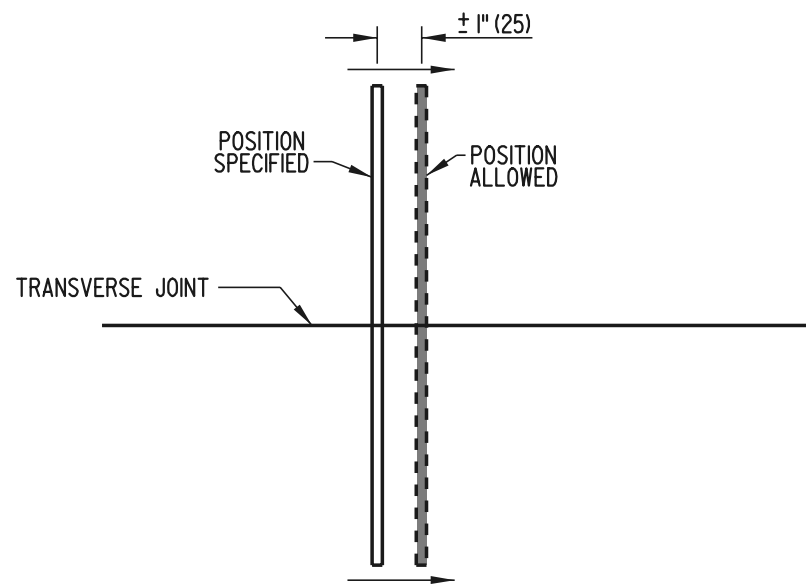

**HORIZONTAL TRANSLATION**

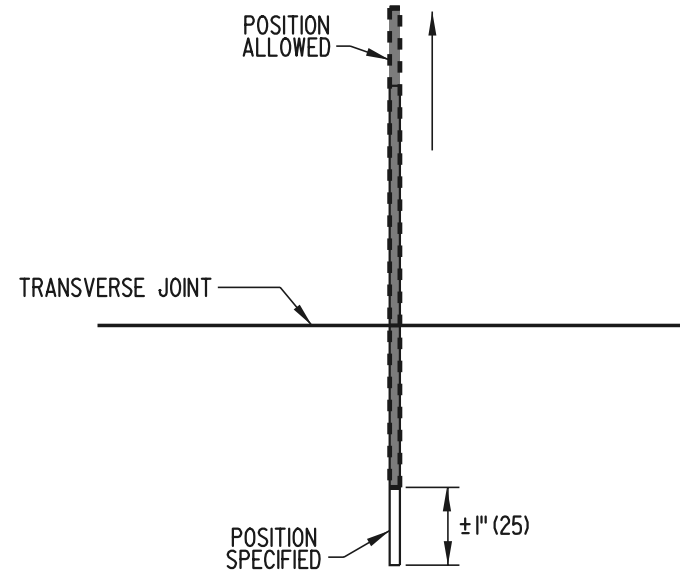

**LONGITUDINAL TRANSLATION**

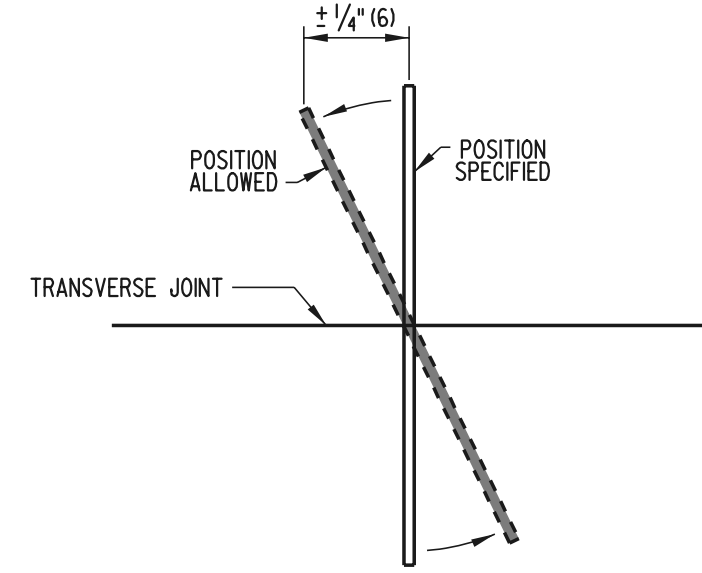

**HORIZONTAL ROTATION**

**DOWEL & TIE BAR PLACEMENT TOLERANCES**



**DELAWARE  
DEPARTMENT OF TRANSPORTATION**

<b>P.C.C. PAVEMENT</b>			
<b>STANDARD NO.</b>	<b>P-1 (2001)</b>	<b>SHT.</b>	<b>5 OF 5</b>

<b>APPROVED</b>	<i>Ryan M. Harshbarger</i>	<b>6/18/01</b>
	<small>CHIEF ENGINEER</small>	<small>DATE</small>
<b>RECOMMENDED</b>	<i>Michael R. [Signature]</i>	<b>6/18/01</b>
	<small>DESIGN ENGINEER</small>	<small>DATE</small>