

PLAN

NOTE: CLOSED CELL POLYETHYLENE FOAM SHALL BE THE SAME WIDTH AS THE JOINT AND 5" (125) IN DEPTH. AFTER THE CONCRETE IN THE REPAIR AREA HAS ACHIEVED THE SPECIFIED STRENGTH, THE FOAM SHALL BE REMOVED AND REPLACED WITH BACKER ROD AND HOT-POUR SEALANT MEETING ALL APPLICABLE STANDARD DETAILS AND SPECIFICATIONS.

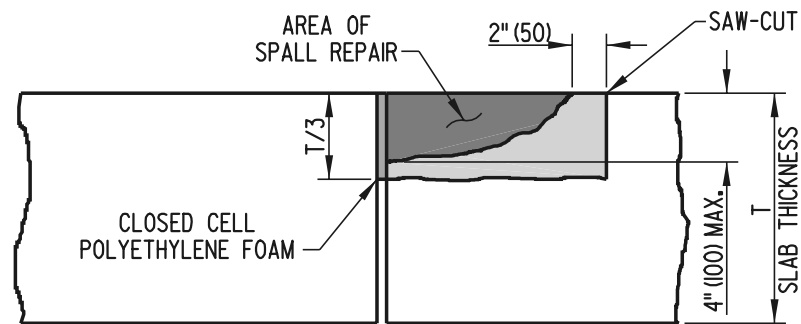

SECTION WITH SPALL ADJACENT TO JOINT

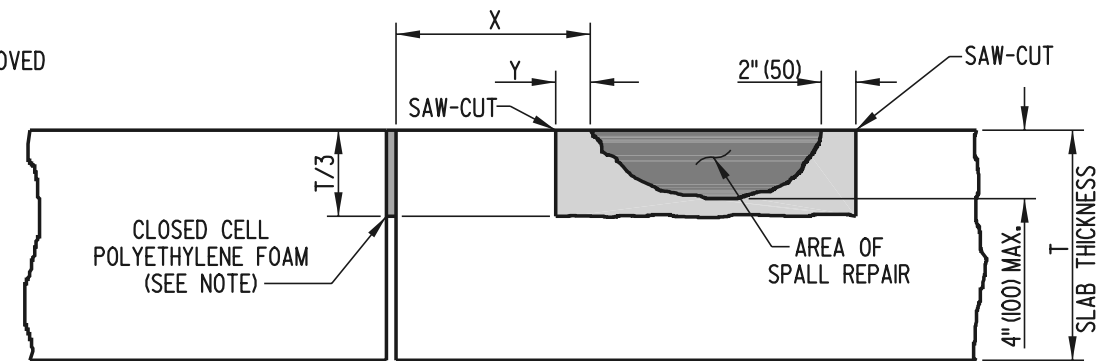

SECTION WITH SPALL NOT ADJACENT TO JOINT

NOTE: WHEN $X > 12"$ (300), THEN $Y=1"$ (25) AND POLYETHYLENE FOAM IS NOT USED. WHEN $X \leq 12"$ (300), THEN $Y=X$ AND POLYETHYLENE FOAM IS USED.

PARTIAL DEPTH PATCH



**DELAWARE
DEPARTMENT OF TRANSPORTATION**

P.C.C. PAVEMENT PATCHING

STANDARD NO. **P-2 (2001)**

SHT. **5** OF **5**

APPROVED *Ryan M. Harshbarger* **6/18/01**
CHIEF ENGINEER DATE

RECOMMENDED *Michael R. [Signature]* **6/18/01**
DESIGN ENGINEER DATE