

W-BEAM ELEVATION

1

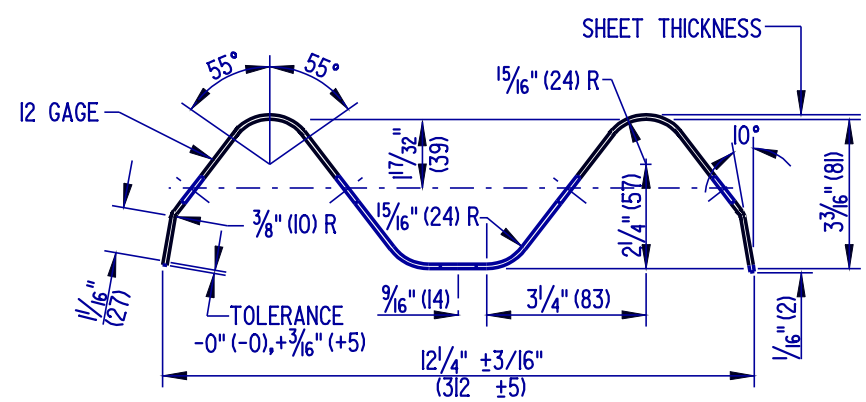

W-BEAM SECTION

NOTES: 1). TWO ADDITIONAL 3/4" (20) x 2 1/2" (65) SLOTS SHALL BE PROVIDED AT 6'-3" (1905) SPACING FOR BEAM LENGTH OF 26'-1/2" (7940).



DELAWARE
DEPARTMENT OF TRANSPORTATION

STANDARD NO. B-13 (2004)		HARDWARE		APPROVED	
SHT. 1	OF 13	RECOMMENDED		DATE	

APPROVED *Carolann Wicks* 1/10/05
CHIEF ENGINEER DATE
RECOMMENDED *Dennis M. O'Flaherty* 1/3/05
DESIGN ENGINEER DATE