

NOTES : 1). ALL HOLES SHALL BE DRILLED PRIOR TO GALVANIZING.
 2). ALL WOOD SIZES ARE NOMINAL DIMENSIONS.

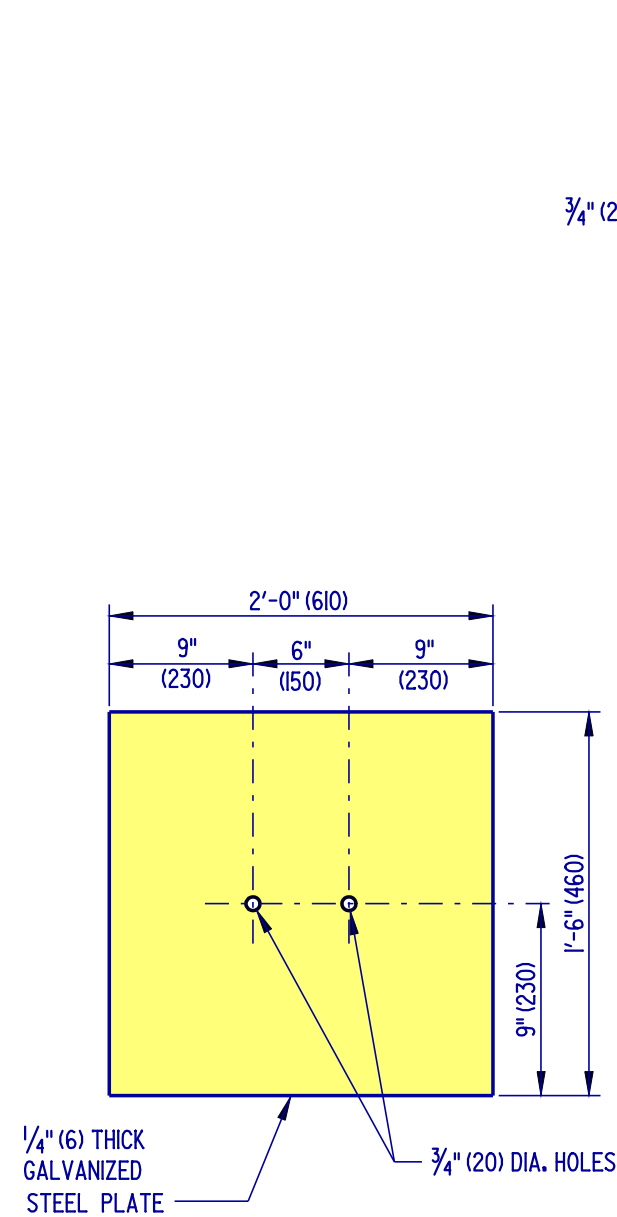

SOIL PLATE

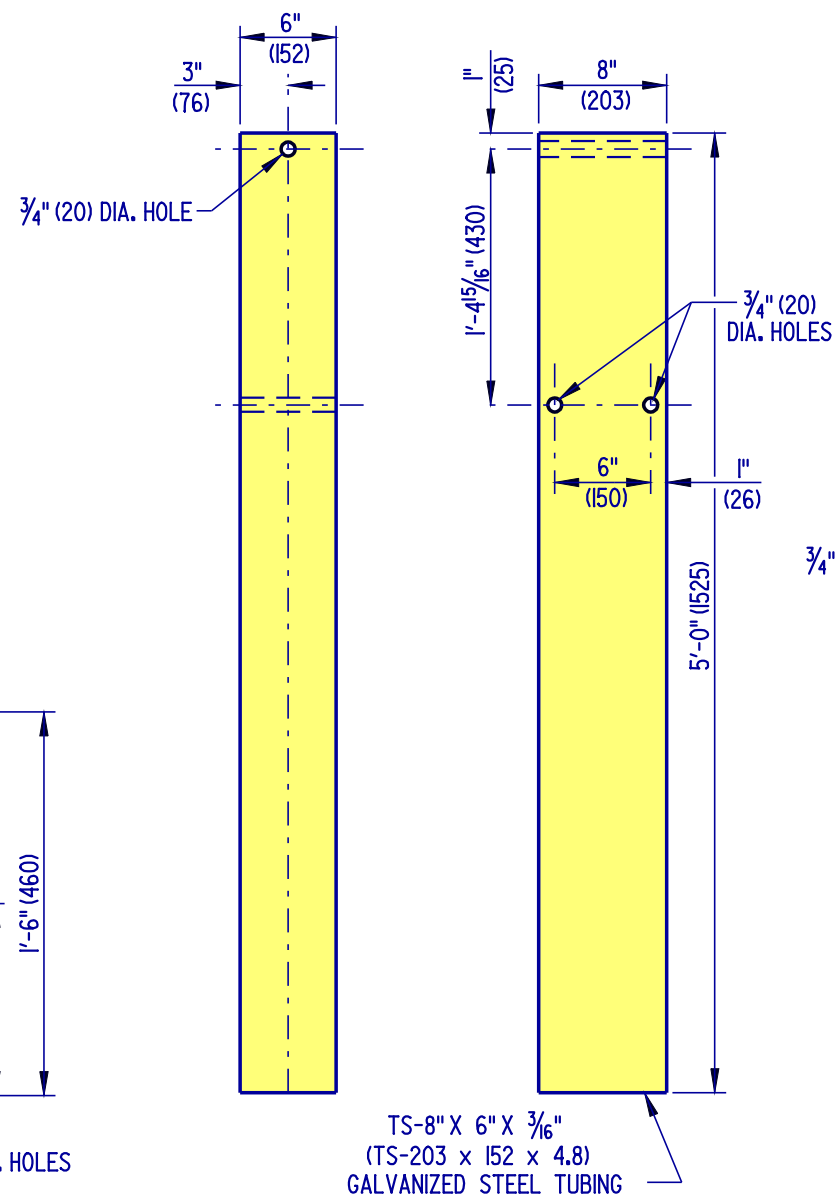

STEEL TUBE

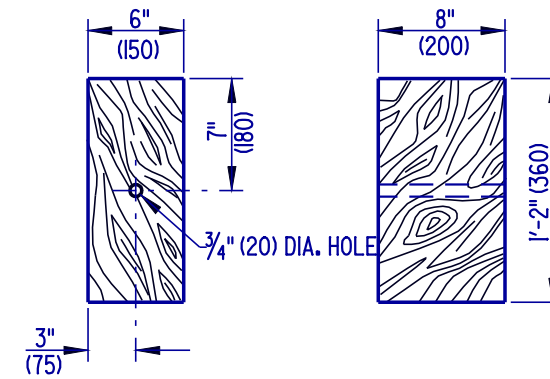

WOOD BLOCK

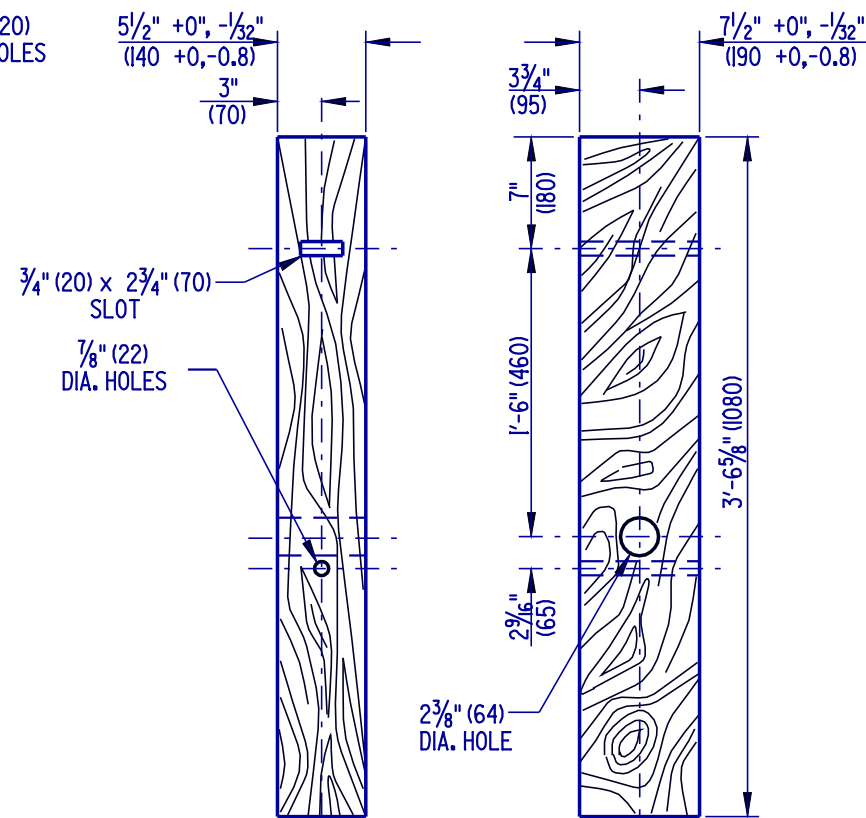

SHORT WOOD BREAKAWAY POST

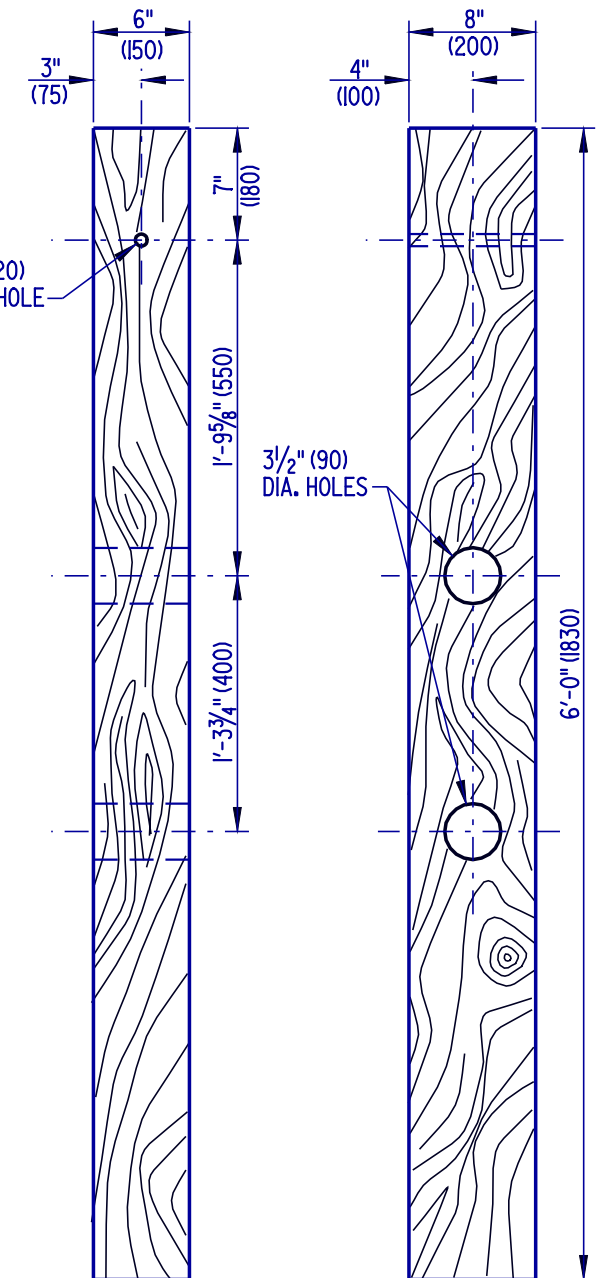

LONG WOOD BREAKAWAY POST



DELAWARE
 DEPARTMENT OF TRANSPORTATION

STANDARD NO. B-13 (2004)

HARDWARE

SHT. 7 OF 13

APPROVED *Carolann Wicks* 1/10/05
 CHIEF ENGINEER DATE

RECOMMENDED *Dennis M. O'Flaherty* 1/13/05
 DESIGN ENGINEER DATE