

ELEVATION A-A

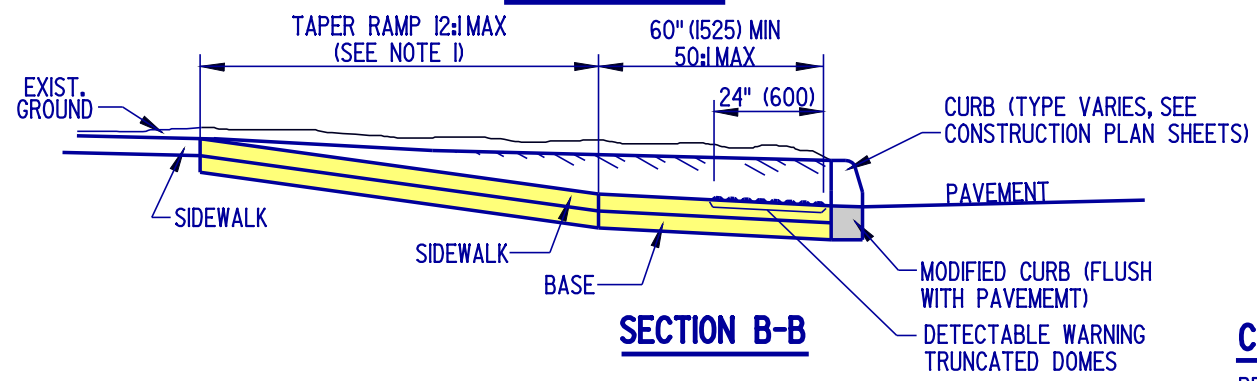

SECTION B-B

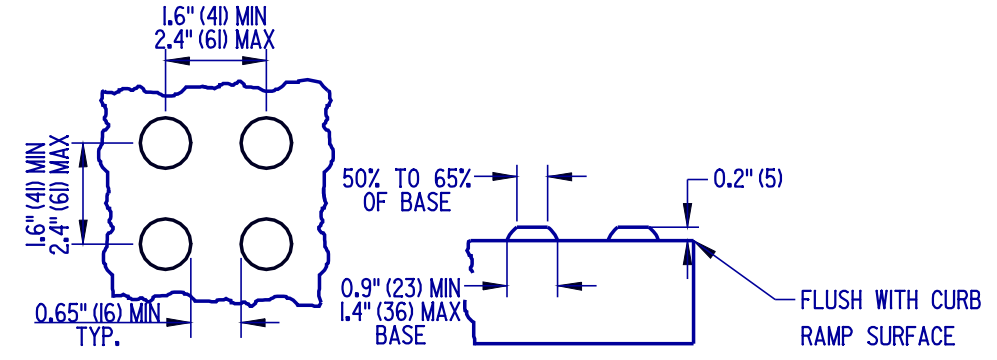

DETECTABLE WARNING TRUNCATED DOME DETAILS

- NOTES:**
- 1) THE AREA OF DETECTABLE WARNING TRUNCATED DOMES SHALL BE 24" (600) LONG AND THE FULL WIDTH OF THE RAMP.
 - 2) SEE SPECIFICATION FOR ADDITIONAL INFORMATION.

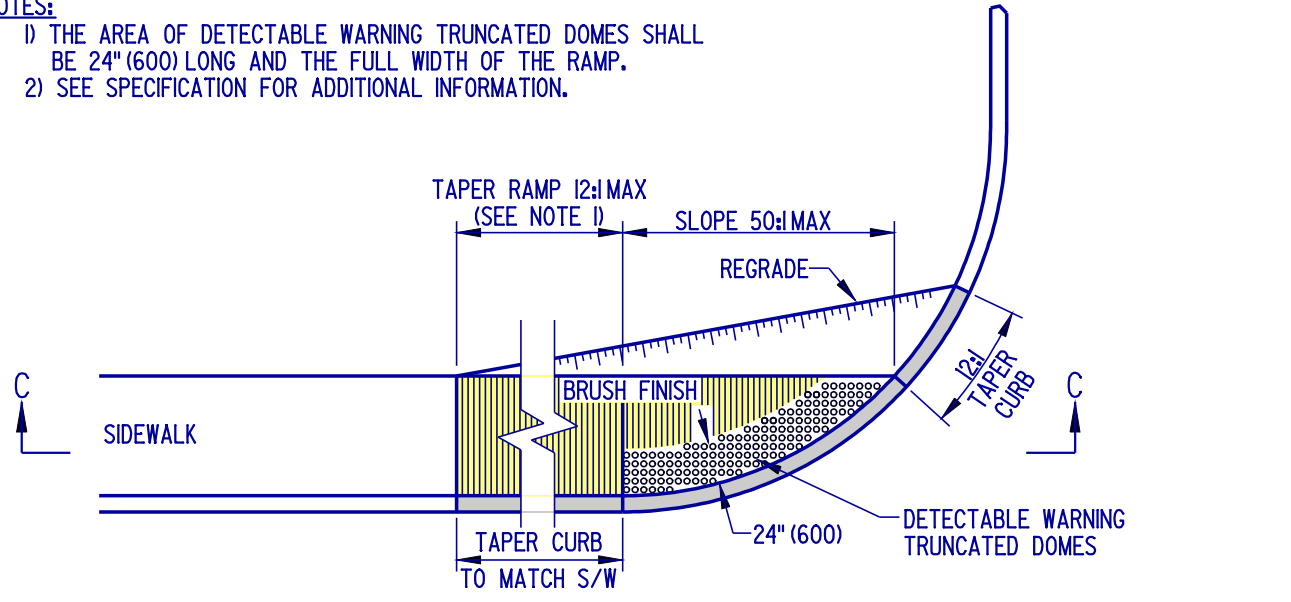

SECTION C-C

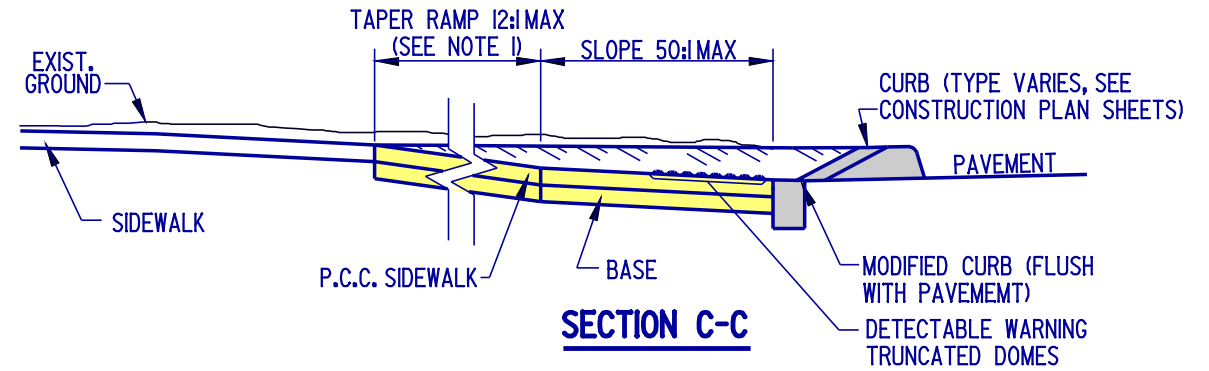

- NOTES:**
- 1). WHERE A 12:1 MAXIMUM SLOPE RAMP WILL NOT MEET THE SIDEWALK GRADE WITHIN A LENGTH OF 15' (4570) DUE TO STEEP ADJACENT ROADWAY, THE RAMP LENGTH MAY BE LIMITED TO 15' (4570), AND THE RAMP SLOPE ALLOWED TO EXCEED 12:1.
 - 2). RAMP WIDTH SHALL BE 4' (1200) MINIMUM, HOWEVER, 5' (1525) IS PREFERRED.

CURB RAMP, TYPE 1
PERPENDICULAR CURB RAMP



DELAWARE
DEPARTMENT OF TRANSPORTATION

CURB RAMP, TYPE 1 AND SECTIONS

STANDARD NO. C-2 (2004) SHT. 1 OF 4

APPROVED *Carolann Wicks* 1/10/05
CHIEF ENGINEER DATE
RECOMMENDED *Dennis M. O'Flaherty* 1/13/05
DESIGN ENGINEER DATE