

SHARED USE PATH INTERSECTION

- NOTES:**
1. THE 4" (100) CONCRETE SHARED-USE PATH SHALL BE FINISHED TO INCLUDE A TEXTURED WARNING SURFACE BY USING A JOINT STRIKE TO PRODUCE A 1/2" (12) DEEP V-JOINT AT 6" (150) O.C. PAYMENT FOR INSTALLING THE GROOVED FINISH SHALL BE INCIDENTAL TO THE SIDEWALK CONSTRUCTION.
 2. FOR 8' (2450) AND 10' (3050) PATH WIDTH, THE OUTSIDE DIMENSION FROM CENTER OF BOLLARD TO EDGE OF PATH SHALL BE 2' (610) AND 3' (915) RESPECTIVELY.
 3. IF THE SHARED USE PATH ENDS AT A ROADWAY, THEN DETECTABLE WARNING TRUNCATED DOMES 24" (600) LONG AND THE FULL WIDTH OF THE PATH SHALL BE INSTALLED. SEE SHEET C-2.
 4. STEEL TUBE TO EXTEND 1/2" (13) ABOVE GROUND WITH CONCRETE TO SLOPE AWAY FROM TUBE TO KEEP WATER AND SEDIMENT FROM DRAINING INTO TUBE.

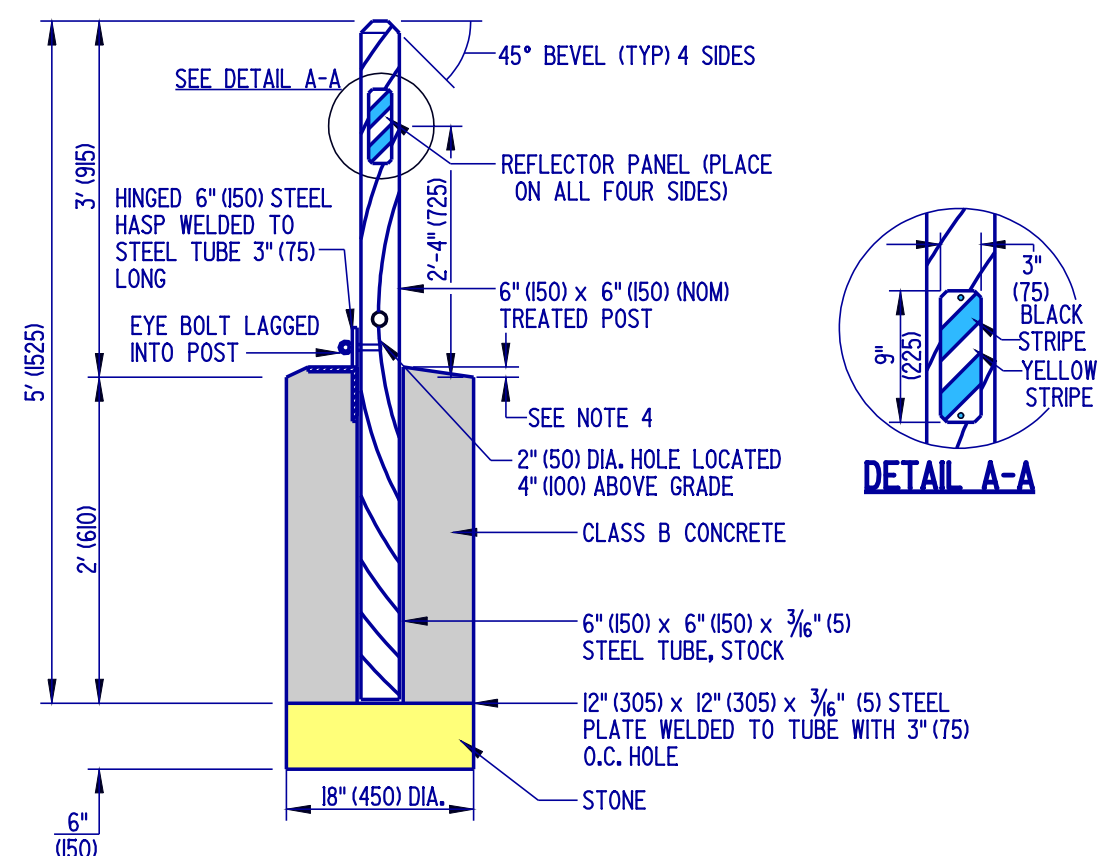

REMOVABLE BOLLARD

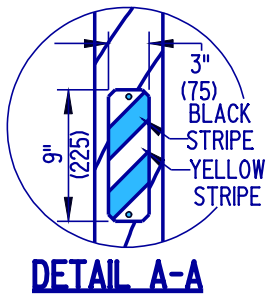

DELAWARE
DEPARTMENT OF TRANSPORTATION

BOLLARD DETAILS					
STANDARD NO.	M-3 (2004)	SHT.	1	OF	1

APPROVED *Carolann Wick* 1/10/05
CHIEF ENGINEER DATE

RECOMMENDED *Dennis M. O'Fl* 1/3/05
DESIGN ENGINEER DATE