

SCALE : N.T.S.

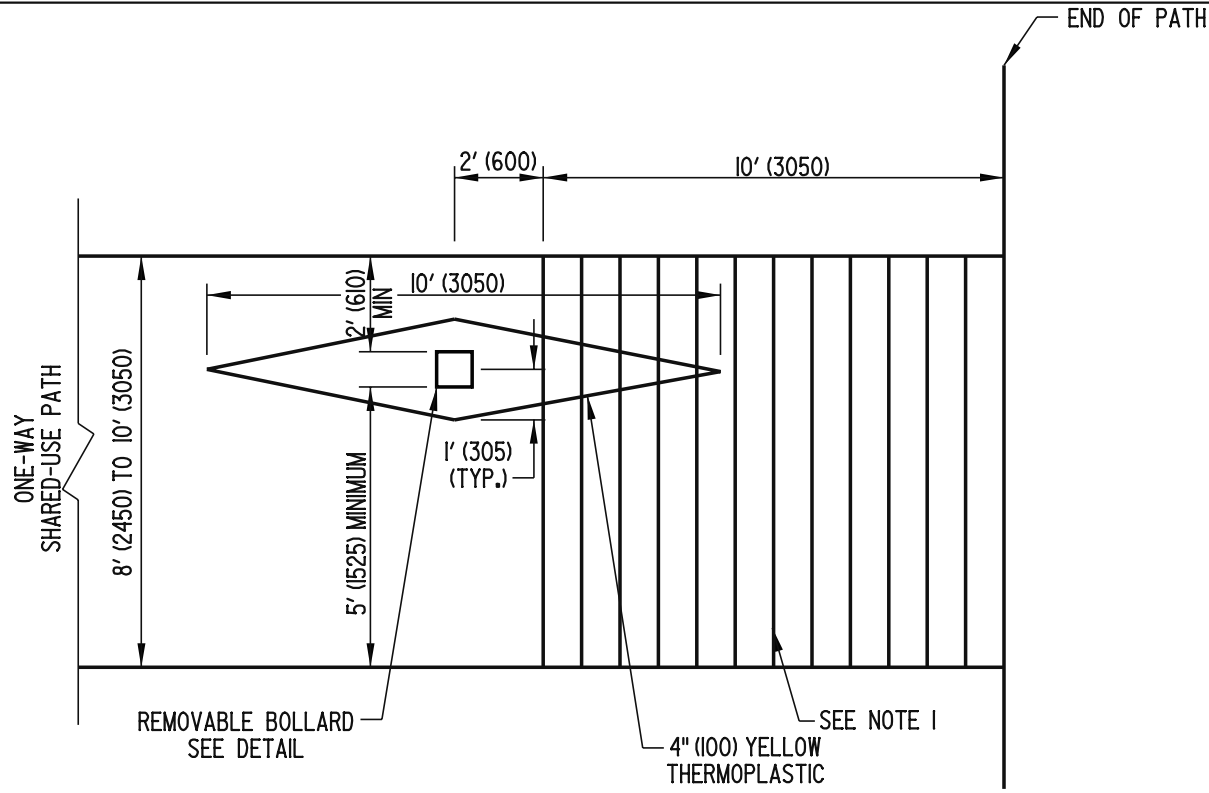

**ONE-WAY SHARED USE
PATH INTERSECTION**

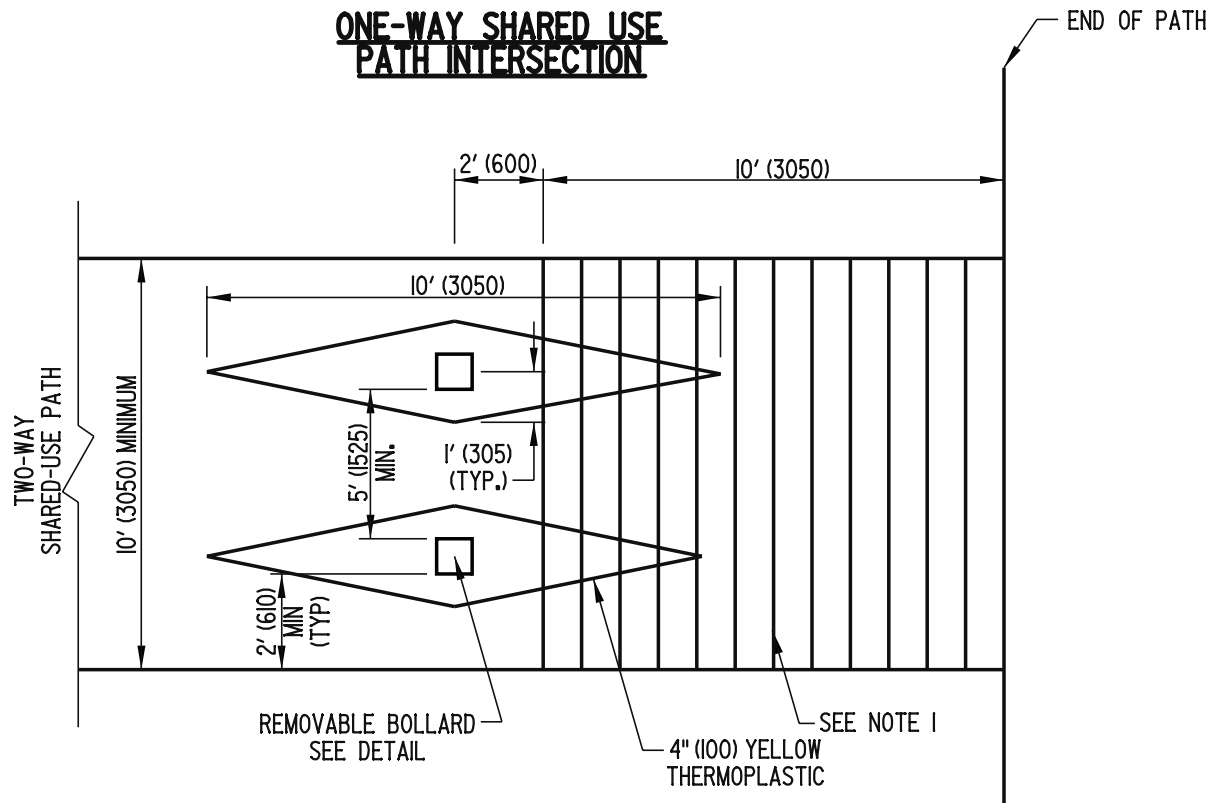

**TWO-WAY SHARED USE
PATH INTERSECTION**

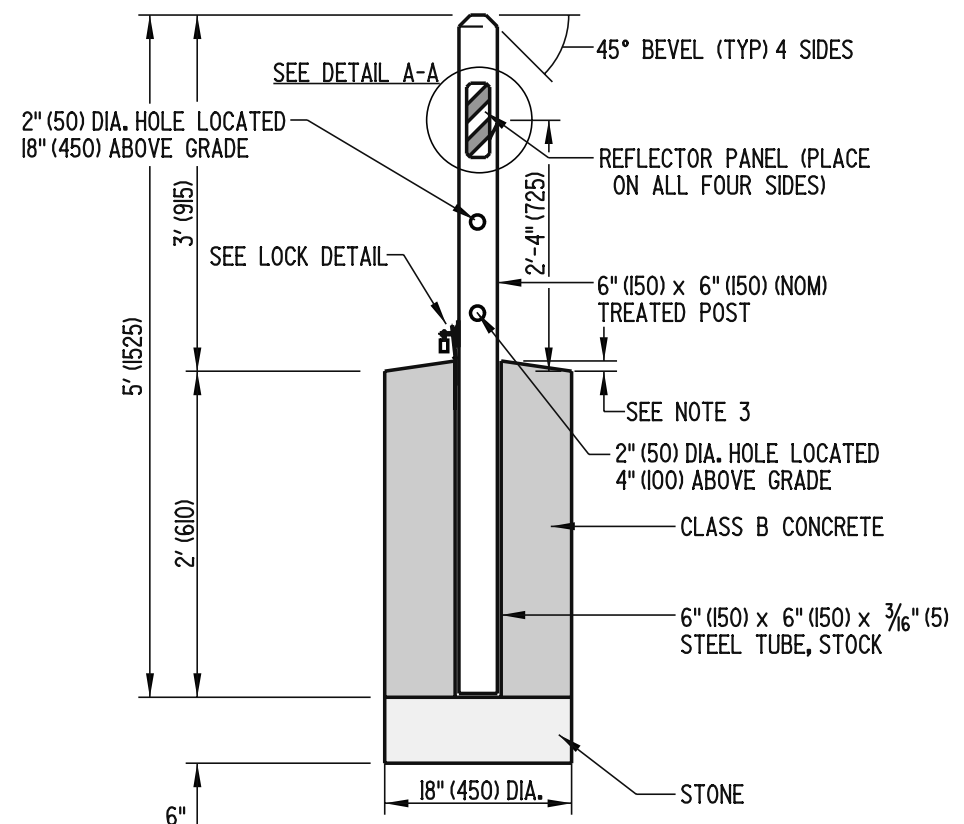

REMOVABLE BOLLARD

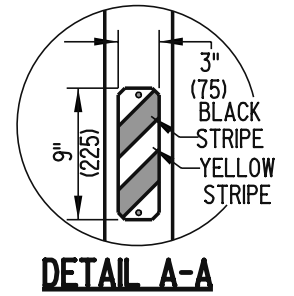
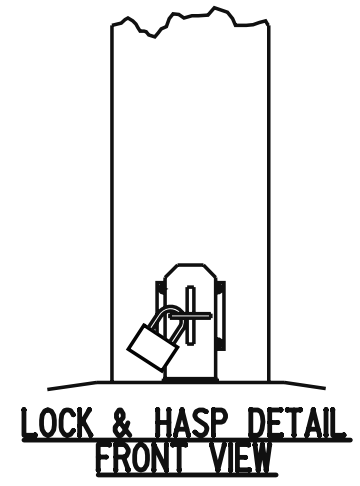

NOTES:

- 1). THE 4" (100) CONCRETE SHARED-USE PATH SHALL BE FINISHED TO INCLUDE A TEXTURED WARNING SURFACE BY USING A JOINT STRIKE TO PRODUCE A 1/2" (12) DEEP V-JOINT AT 6" (150) O.C. PAYMENT FOR INSTALLING THE GROOVED FINISH SHALL BE INCIDENTAL TO THE SIDEWALK CONSTRUCTION.
- 2). IF THE SHARED USE PATH ENDS AT A ROADWAY OR RAILROAD CROSSING, THEN DETECTABLE WARNING TRUNCATED DOMES 24" (600) LONG AND THE FULL WIDTH OF THE PATH SHALL BE INSTALLED. SEE SHEET C-2.
- 3). STEEL TUBE TO EXTEND 1/2" (13) ABOVE GROUND WITH CONCRETE TO SLOPE AWAY FROM TUBE TO KEEP WATER AND SEDIMENT FROM DRAINING INTO TUBE.
- 4). BOLLARDS ARE NOT REQUIRED FOR A SHARED-USE PATH LESS THAN 8' (2450) WIDE.
- 5.) SHAVE THE POST AS NECESSARY SO THAT IT WILL FIT IN THE STEEL TUBE.



**DELAWARE
DEPARTMENT OF TRANSPORTATION**

BOLLARD DETAILS			
STANDARD NO.	M-3 (2005)	SHT.	1 OF 1

APPROVED *Candace Wick* 12/15/05
CHIEF ENGINEER DATE

RECOMMENDED *James M. O'Brien* 11/29/05
DESIGN ENGINEER DATE