

| MIN. * OUTFALL PIPE DIA. | MIN. RISER DIA. | MAX. DRAINAGE AREA ACRES (ha) |
|--------------------------------|--------------------|-------------------------------------|
| 12" (300) | 15" (375) | 1 (0.4) |
| 15" (375) | 18" (450) | 2 (0.8) |
| 18" (450) | 21" (525) | 3 (1.2) |
| 21" (525) | 24" (600) | 4 (1.6) |
| 24" (600) | 27" (675) | 5 (2.0) |

* OUTFALL PIPE DIAMETER MAY BE SAME SIZE AS RISER DIAMETER.

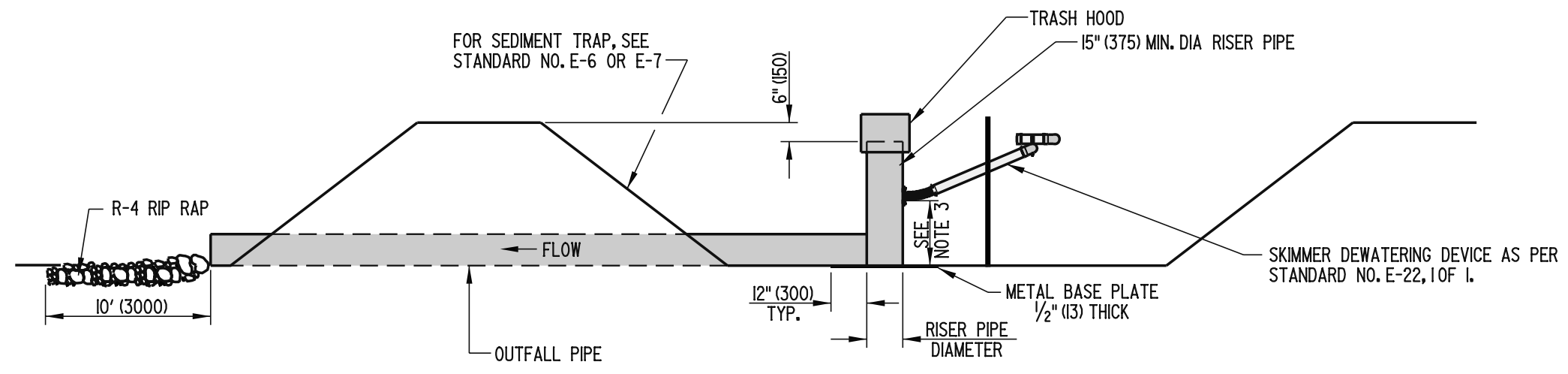

- NOTES:**
- 1). THIS DEVICE IS INTENDED TO BE USED AS AN OUTLET FOR SEDIMENT TRAPS.
 - 2). THE PIPE OUTLET SHOWN SHALL ONLY BE USED WITH SEDIMENT TRAPS WITH DRAINAGE AREAS OF 5 ACRES (2.0 HECTARES) OR LESS. LARGER DRAINAGE AREAS REQUIRE AN ENGINEERED DESIGN.
 - 3). THE HEIGHT OF THE SKIMMER DEWATERING DEVICE SHALL BE SPECIFIED BY THE ENGINEER IN THE FIELD.