

P.C.C. CURB
TYPE 1

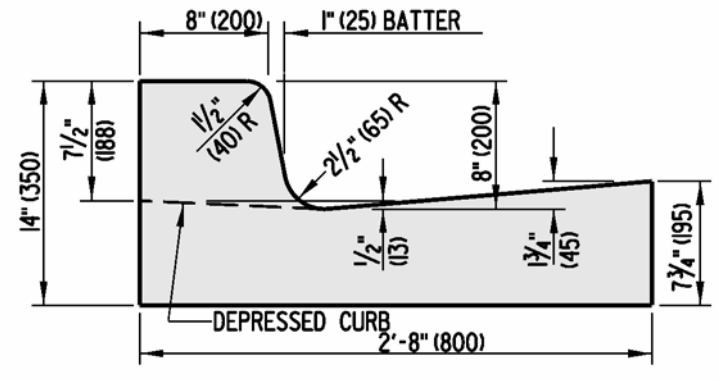

INTEGRAL P.C.C. CURB AND GUTTER
TYPE 1

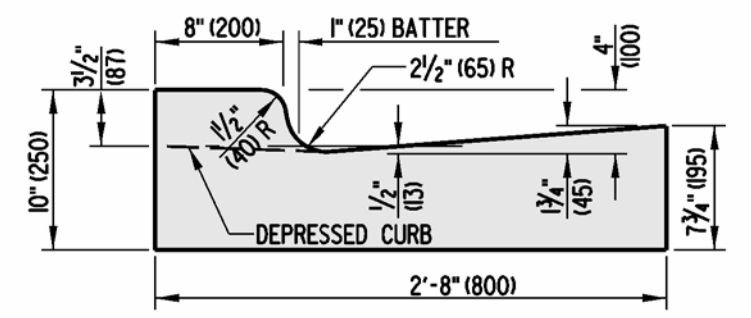

INTEGRAL P.C.C. CURB AND GUTTER
TYPE 4

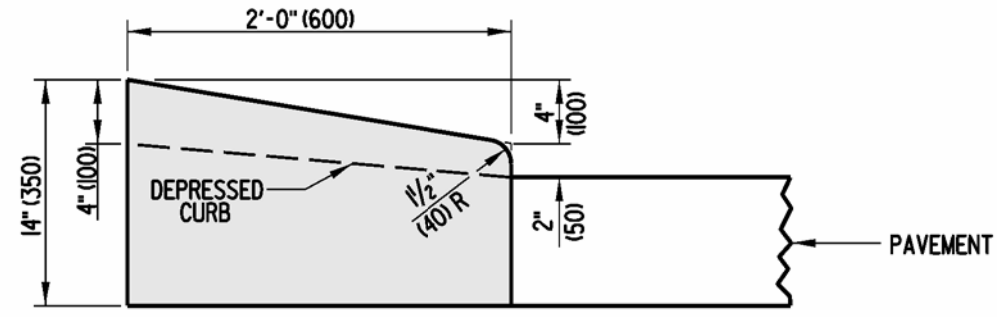

P.C.C. CURB
TYPE 2

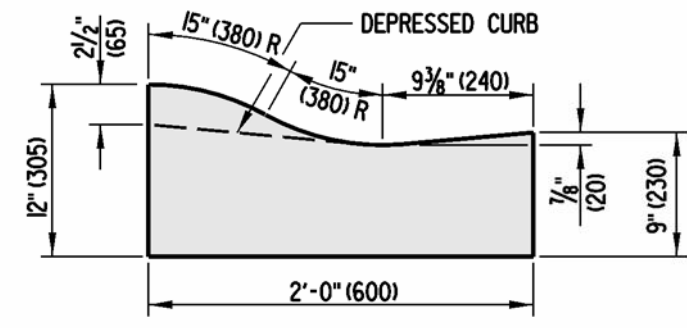

INTEGRAL P.C.C. CURB AND GUTTER
TYPE 2

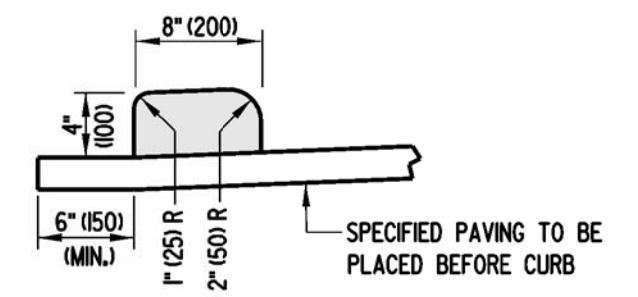

HOT-MIX, HOT LAID BITUMINOUS CONCRETE CURB

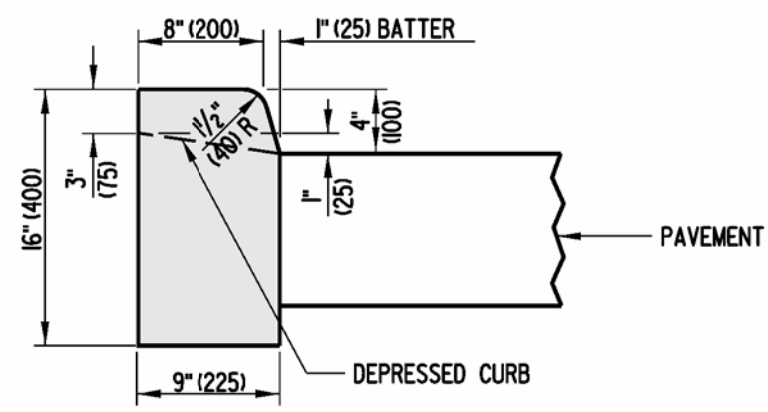

P.C.C. CURB
TYPE 3

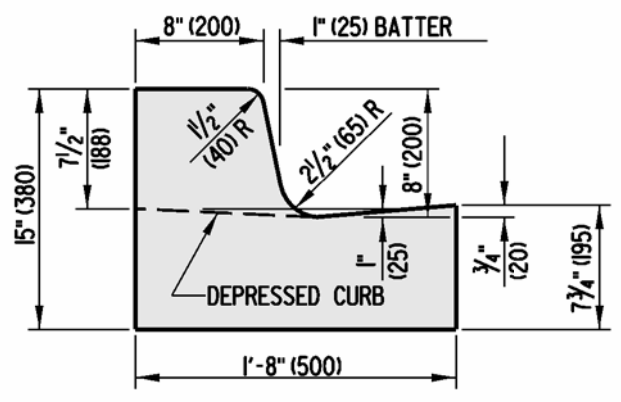

INTEGRAL P.C.C. CURB AND GUTTER
TYPE 3

NOTES:

1. WHEN P.C.C. CURB OR INTEGRAL P.C.C. CURB AND GUTTER IS PLACED ADJACENT TO PORTLAND CEMENT CONCRETE PAVEMENT, CONSTRUCT THE JOINT AS PER THE LONGITUDINAL JOINT SEALANT DETAIL ON DETAIL P-2, SHEET 3 OF 5. USE APPROVED JOINT FILLER TO SEAL. WORK TO BE PAID UNDER RESPECTIVE CURB AND GUTTER ITEM.
2. DEPRESS CURB AT ENTRANCES AND CURB RAMPS AS DETAILED ON THIS SHEET.
3. DEPRESS CURB FLUSH WITH PAVEMENT AT CURB RAMPS. MAXIMUM SLOPE OF CURB AT CURB RAMPS IS 20:1 IN THE DIRECTION OF PEDESTRIAN TRAVEL. SEE DETAIL C-2, SHEET 1 OF 4.
4. DEPRESS CURB FLUSH WITH PAVEMENT OR ADJACENT AREA AT NOSE OF ISLANDS, TAPERING BACK TO FULL HEIGHT AT A SLOPE OF 12:1.