

SINGLE GRATE SETUP

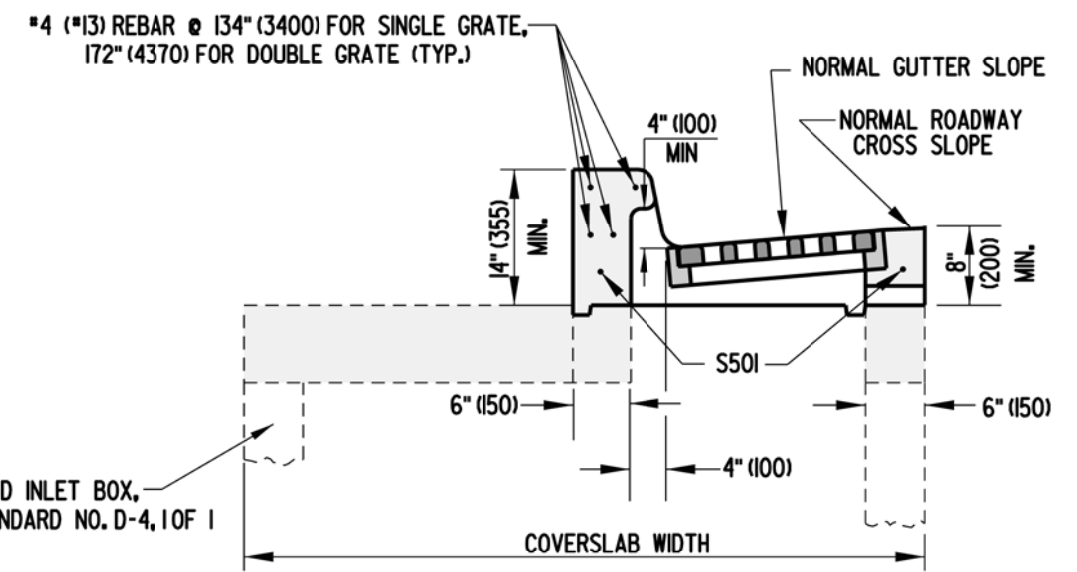

SUBDIVISION TOP & CONFIGURATION

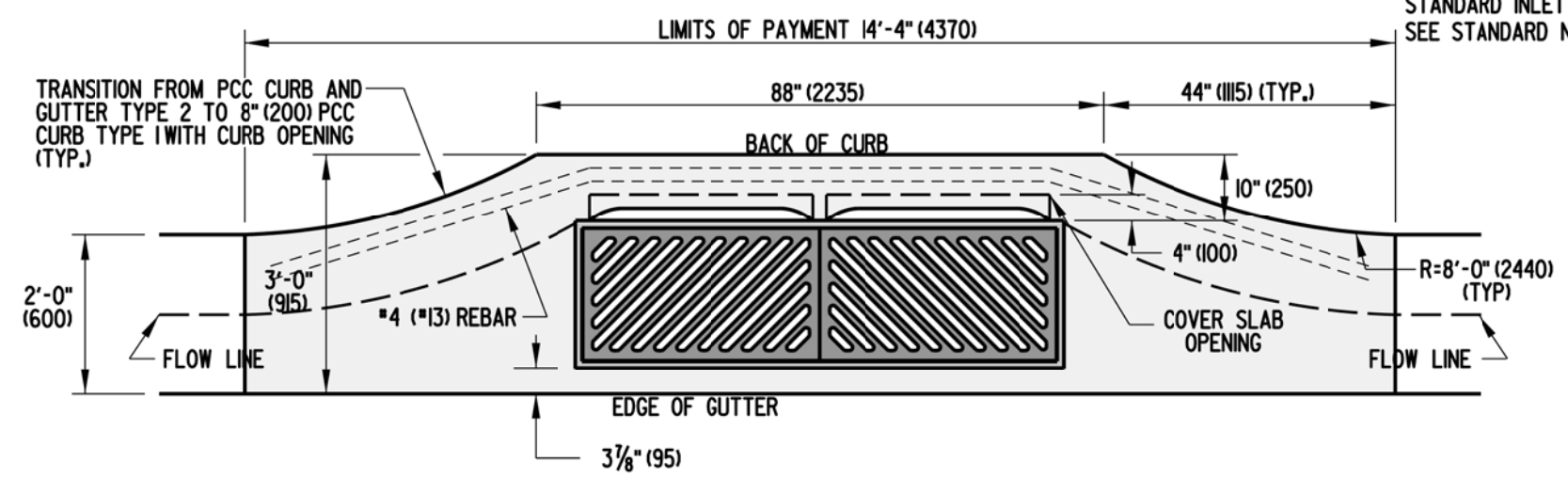

DOUBLE GRATE SETUP

- NOTES:**
- 1). MINIMUM BOX SIZE TO BE 34" (850) X 24" (600).
 - 2). PIPE OPENINGS IN THE FRONT WALL SHALL NOT INTERFERE WITH THE STEPS. THE PIPE SHALL BE SHIFTED HORIZONTALLY TO AVOID THE STEPS. IT MAY BE NECESSARY TO USE A LARGER BOX TO AVOID CONFLICT BETWEEN STEPS AND PIPE OPENING.
 - 3). SEE DETAIL D-5, SHEET 3 OF 9 FOR S501 BAR DIAGRAM.