

SCALE : N.T.S.

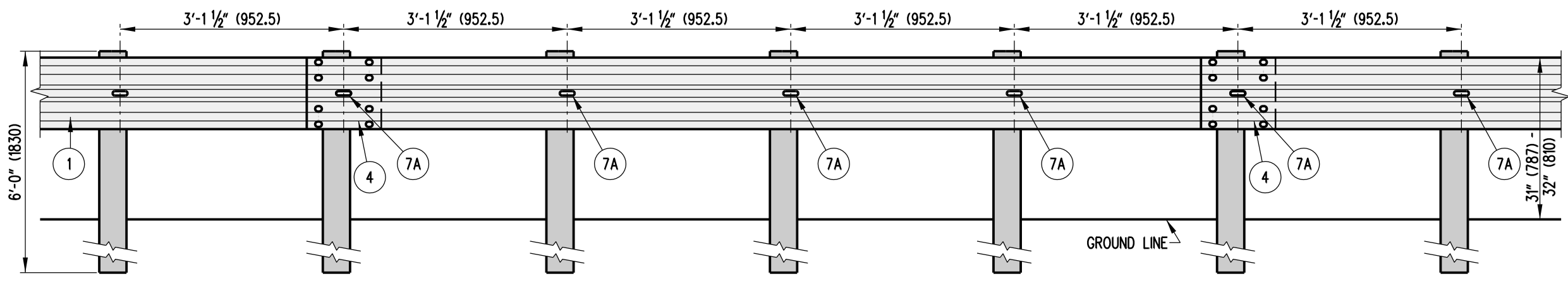

**TYPE 2-31**

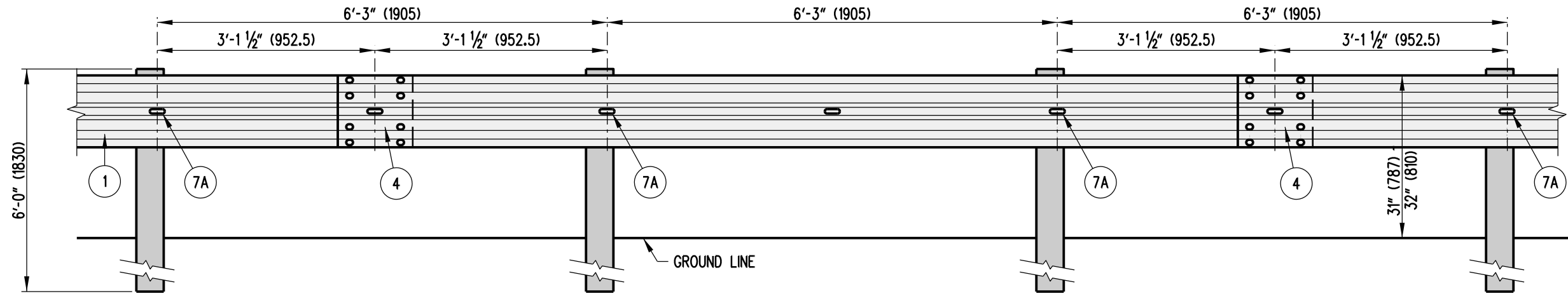

**TYPE 1-31 OR 3-31**

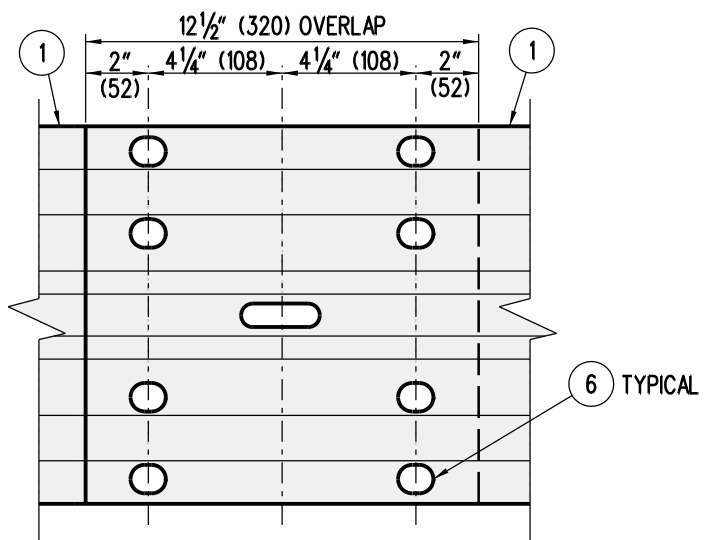

**4 SPLICE DETAIL**

NOTE : OVERLAP W-BEAMS IN DIRECTION OF TRAVEL.

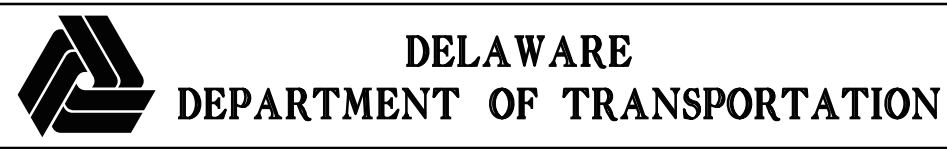

**DELAWARE**

**DEPARTMENT OF TRANSPORTATION**

**TYPES 1-31, 2-31, AND 3-31 GUARDRAIL APPLICATIONS**

**STANDARD NO. B-1 (2010)**

**SHT. 2 OF 3**

**APPROVED**

SIGNATURE ON FILE  
CHIEF ENGINEER

12/28/2010  
DATE

**RECOMMENDED**

SIGNATURE ON FILE  
DESIGN ENGINEER

12/27/2010  
DATE