

SWAGED CABLE ASSEMBLY AND RELATED HARDWARE ASSEMBLY

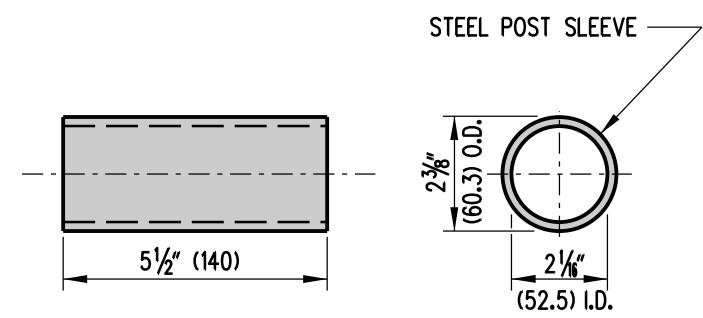

POST SLEEVE

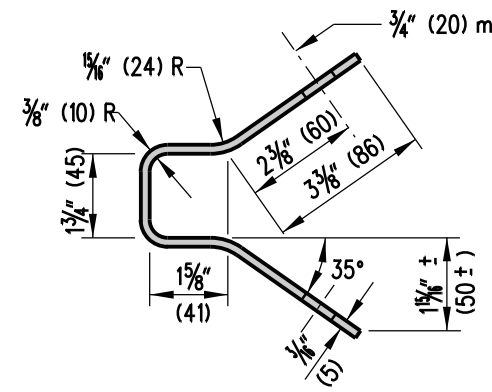

SECTION A-A

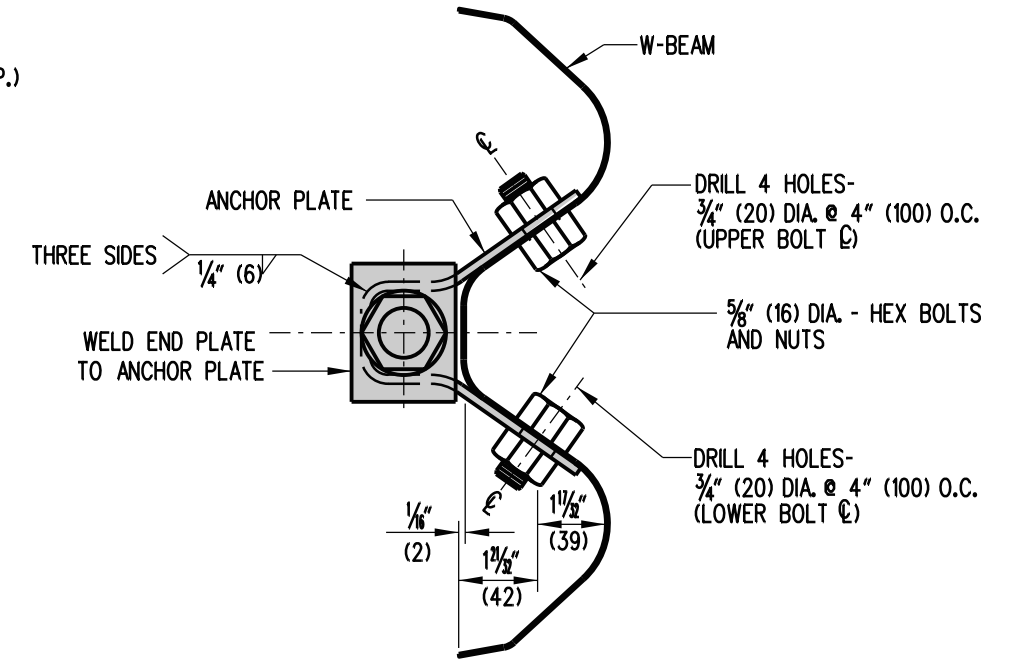

ANCHOR PLATE TO W-BEAM CONNECTION DETAIL

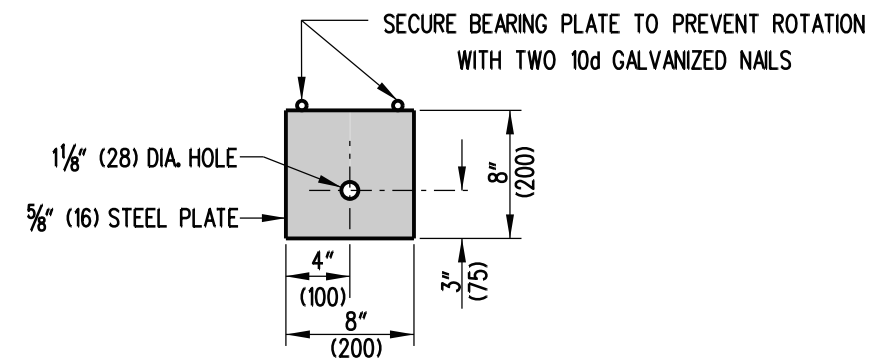

TIMBER BEARING PLATE

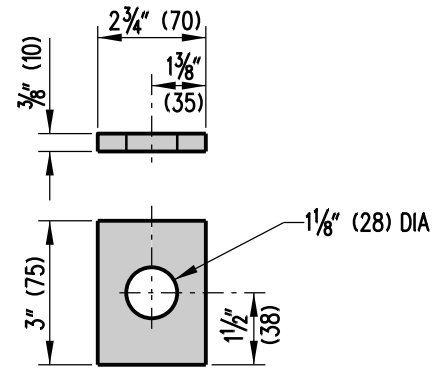

END PLATE

- NOTES: 1). TO ENSURE THAT THE TIMBER BEARING PLATE REMAINS IN POSITION, 2 - 10d GALVANIZED STEEL NAILS SHALL BE DRIVEN IN THE SHORT TIMBER BREAKAWAY POST, AND BENT OVER BEARING PLATE.
- 2). TIGHTEN ASSEMBLY UNTIL CABLE IS TAUGHT.
- 3). ALL HOLES SHALL BE DRILLED PRIOR TO GALVANIZING.