

TRUSS ROD ATTACHMENT

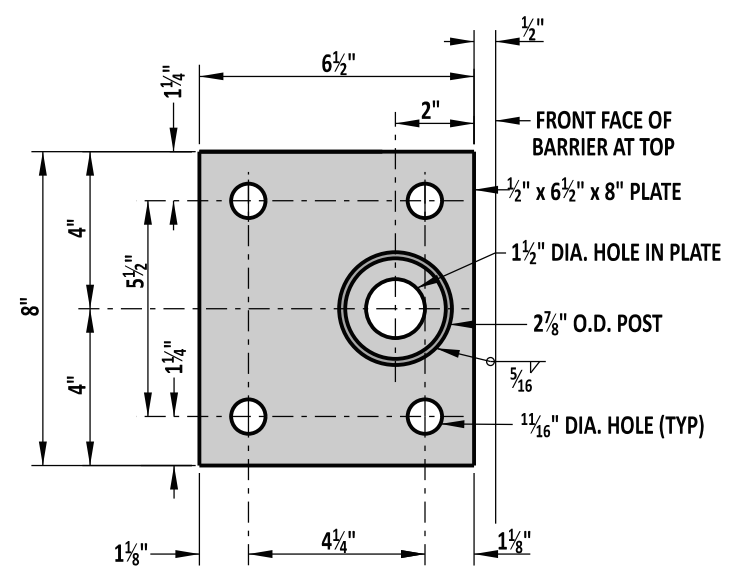

DETAIL 'A'

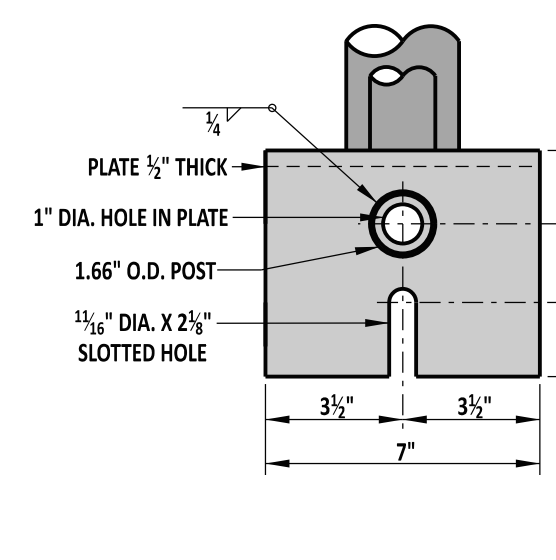

SIDE VIEW

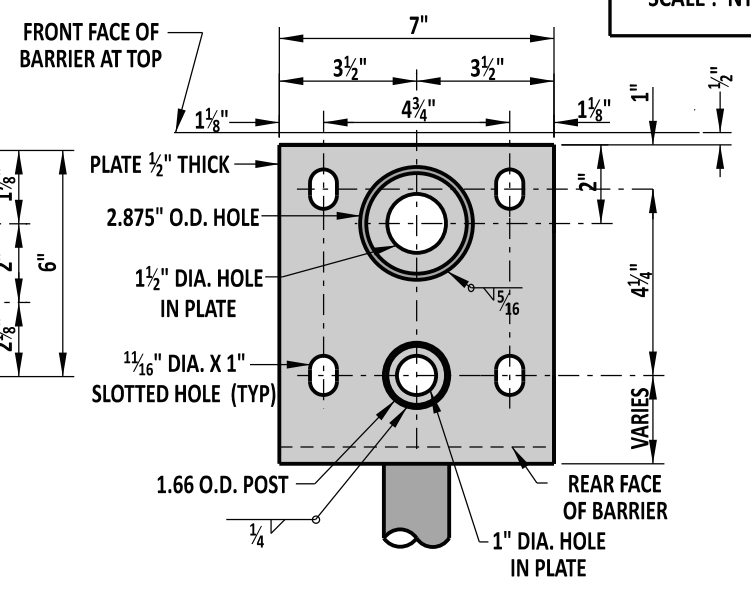

PLAN VIEW

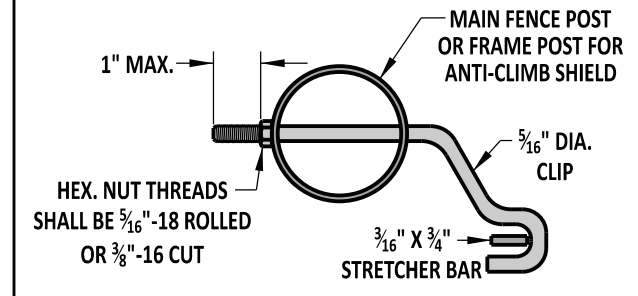

STRETCHER BAR ATTACHMENT

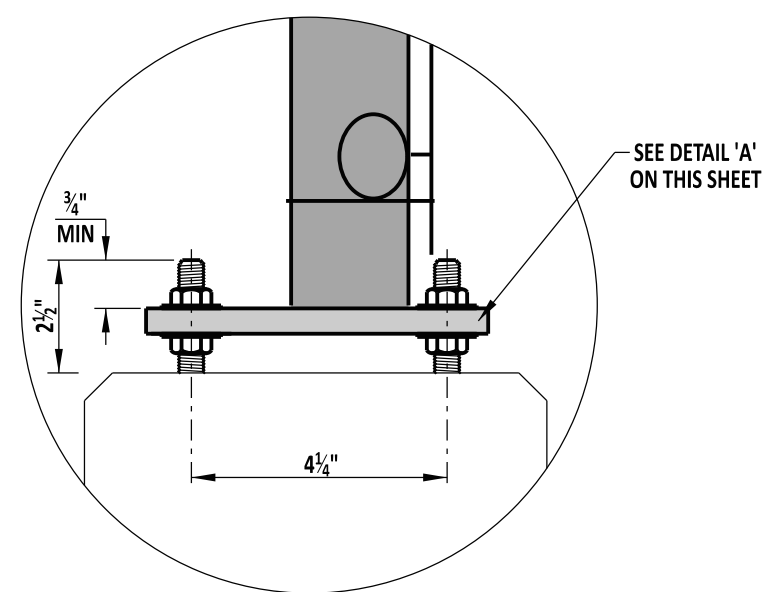

POST TO BARRIER CONNECTION 'A'
TYPICAL CONNECTION FOR POSTS WITHOUT ANTI-CLIMB SHIELD

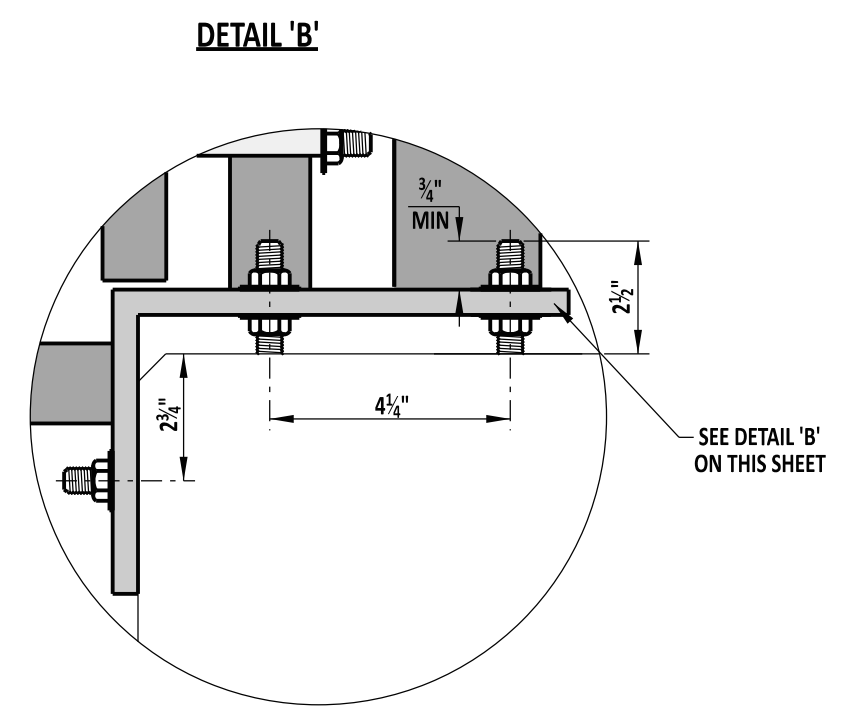

POST TO BARRIER CONNECTION 'B'
TYPICAL CONNECTION FOR POSTS WITH ANTI-CLIMB SHIELD

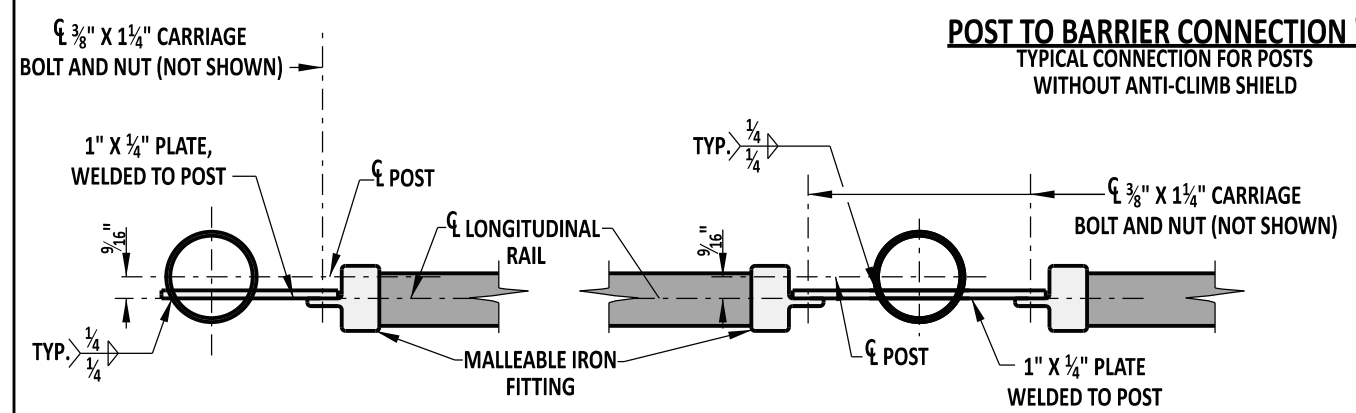

TOP LONGITUDINAL RAIL-POST ATTACHMENT

- NOTES:**
- 1). POST SPACING - POST SPACING TO BE DETERMINED BY THE CONTRACTOR AND INCLUDED IN THE WORKING DRAWINGS. EACH POST MUST BE A MINIMUM OF 1'-0" FROM ANY PARAPET JOINT.
 - 2). WORKING DRAWINGS - WORKING DRAWINGS WILL BE SUBMITTED BY THE CONTRACTOR TO THE ENGINEER FOR REVIEW