

| COUNTY | CONTRACT | F. R. A. REG. NO. | STATE | FED. AID PROJECT NO. | SHEET NO. | TOTAL SHEETS |
|--------------------------------|----------|-------------------|--------|----------------------|-----------|--------------|
| | | 2 | DEL. | | | |
| STANDARD SHEET C-4 | | | | | | |
| GUTTER, HOT-MIX CURB | | | | | | |
| PREL. TRACING | J.T.B. | DESIGN | E.L.W. | CHKD. | E.L.W. | |
| REVISIONS | | | | | | |
| ADDED HOT-MIX CURB | 10-30-70 | J.T.B. | | | | |
| DELETED CONCRETE GUTTER TYPE 2 | 11-7-70 | E.L.W. | | | | |
| ADDED HOT-MIX CURB, TYPE 2 | 10-7-75 | R.F.R. | | | | |
| REVISED CURB TITLES 1-31-77 | R.F.R. | | | | | |
| APPROVED <i>[Signature]</i> | | | | | | 6-22-70 |
| DIRECTOR OF OPERATIONS | | | | | | DATE |
| <i>[Signature]</i> | | | | | | 6/22/70 |
| DEPUTY DIRECTOR-CHIEF ENGINEER | | | | | | DATE |

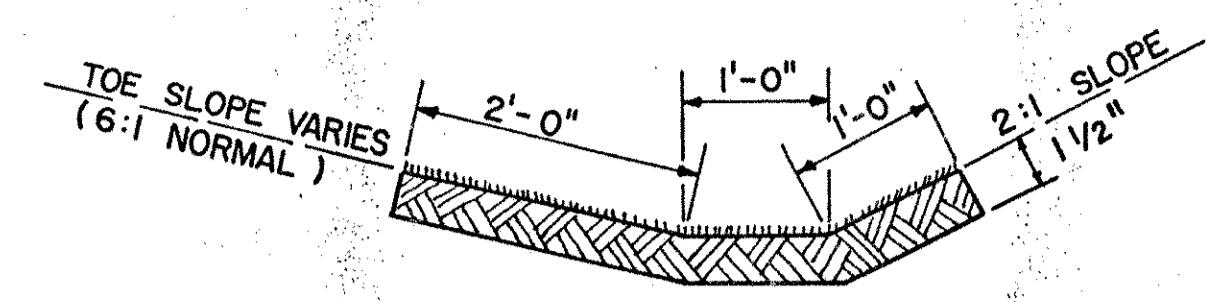

SOD GUTTER

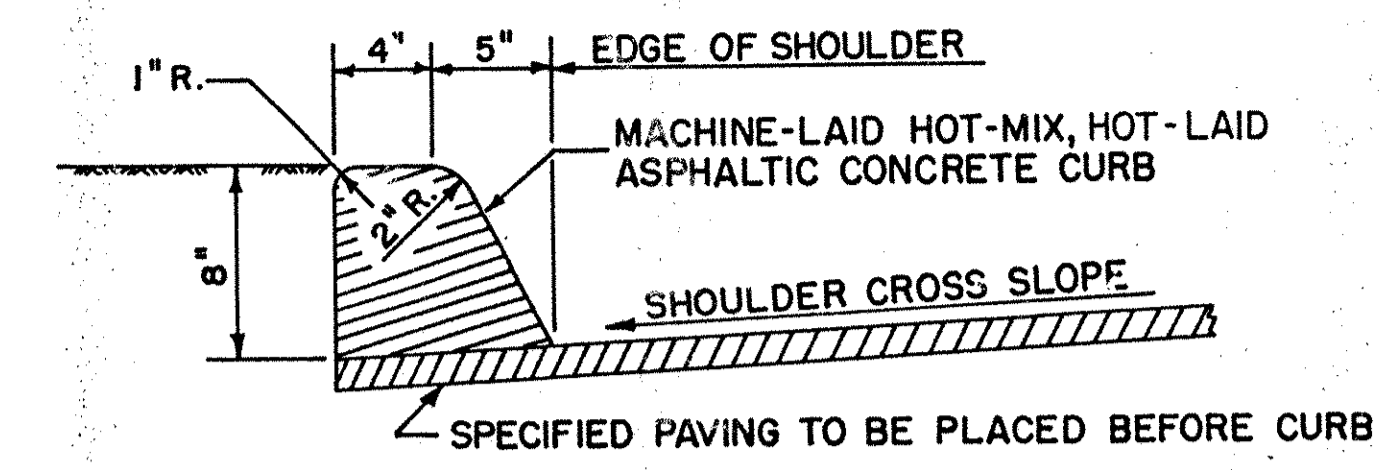
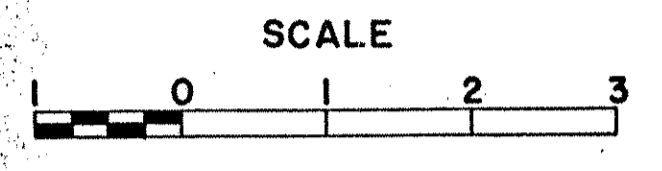

**HOT-MIX, HOT LAID
BITUMINOUS CONCRETE CURB
TYPE 1**

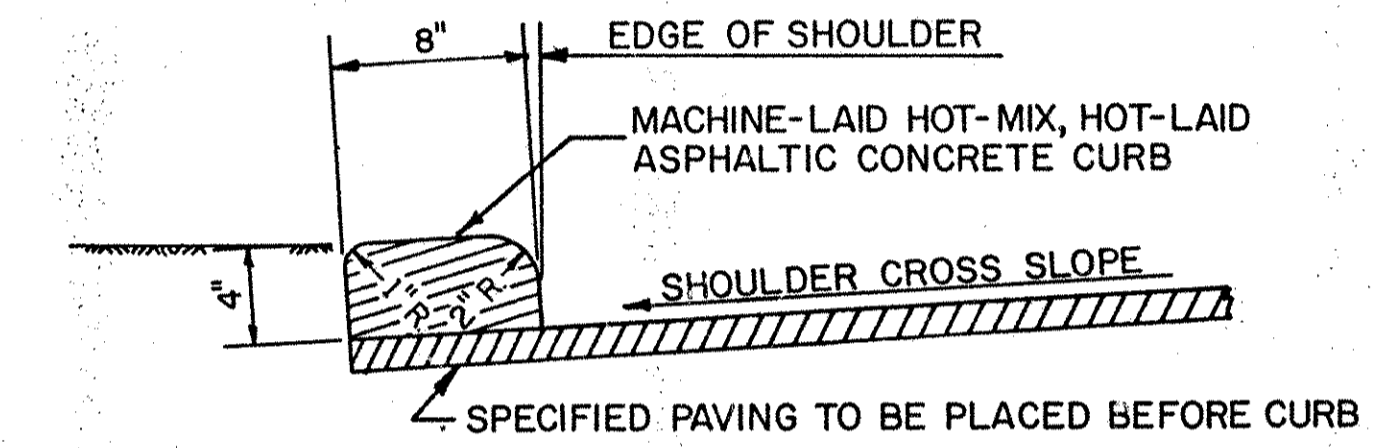
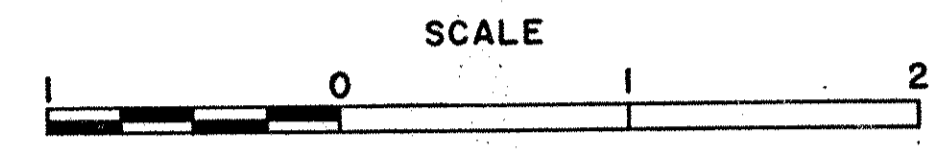

**HOT-MIX, HOT-LAID
BITUMINOUS CONCRETE CURB
TYPE 2**

