

**LIMIT OF CONSTRUCTION  
RAMP Q  
STATION 1028 + 50**

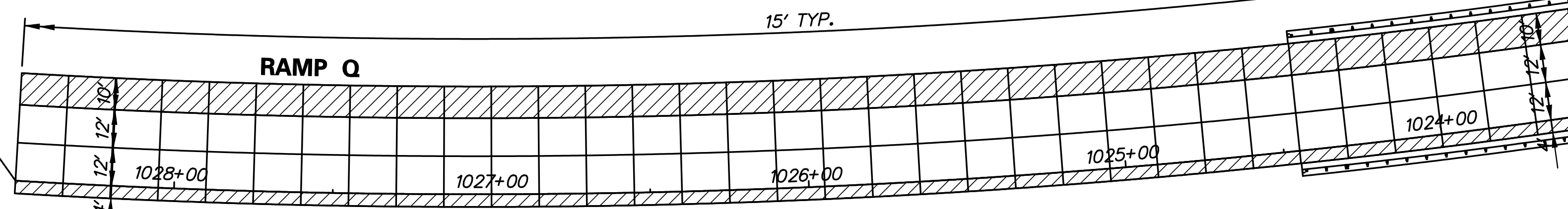

**BEGIN  
CONTRACT T200911302  
STATION 848 + 00**

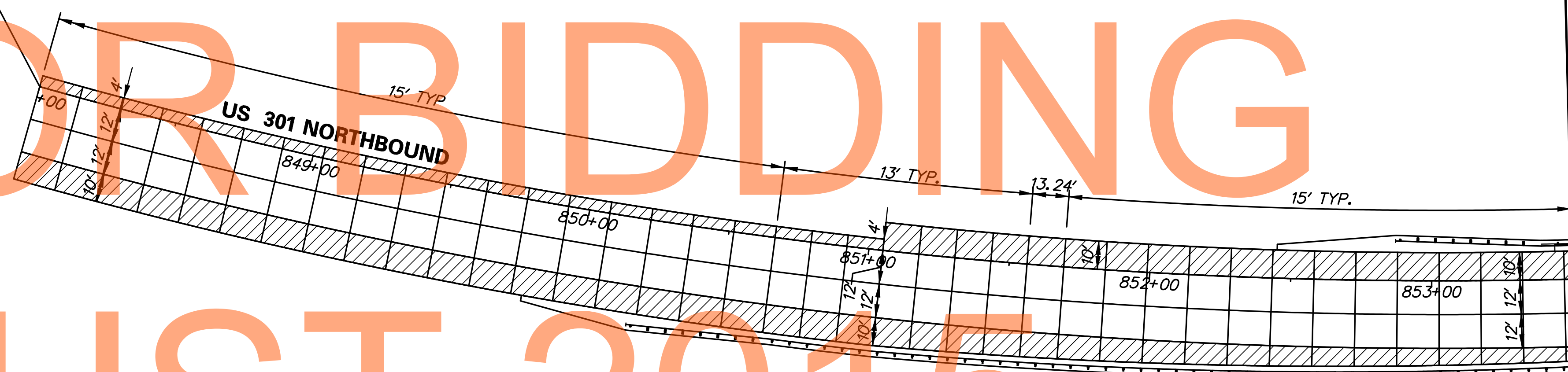

DRAFT  
NOT FOR BIDDING  
AUGUST 2015

MATCH LINE STA. 1023 + 50 -  
SEE DRAWING EX-02

MATCH LINE STA. 853 + 50 -  
SEE DRAWING EX-02

AREA NOT SUBJECT TO IRITESTING PER ITEM 501506 - RIDE QUALITY OF PORTLAND CEMENT CONCRETE PAVEMENT

**NOTES:**

1. JOINT LAYOUT AS SHOWN ON THE PLANS IS GRAPHICAL AND IT IS THE RESPONSIBILITY OF THE CONTRACTOR TO CONSTRUCT THE JOINTS ACCORDING TO THE STANDARD DETAILS AND THESE GENERAL NOTES.
2. TYPICAL TRANSVERSE JOINT SPACING IS 15'.
3. THE MAXIMUM SLAB WIDTH IS 14' UNLESS OTHERWISE NOTED ON THE PLANS OR APPROVED BY THE ENGINEER.
4. THE MINIMUM SLAB WIDTH IS 4'.
5. THE MINIMUM TRANSVERSE JOINT SPACING IS 12'. THE MAXIMUM TRANSVERSE SPACING IS 17'. MAXIMUM AND MINIMUM SPACING ON CURVES SHALL BE MEASURED ALONG THE LONGEST CHORD. THE MAXIMUM AND MINIMUM SPACING FOR CURVES ON THE US 301 MAINLINE SHOULD BE CALCULATED FOR FUTURE LANE EXPANSION INTO THE MEDIAN WHERE APPLICABLE.
6. PAVEMENT CROSS SLOPES AND TRANSITION LENGTHS SHALL BE ADJUSTED AS NEEDED PER LOCATION AND TO MEET DESIGN CRITERIA.
7. IN CURVED SECTIONS, SLAB DIMENSIONS ARE PROVIDED ALONG THE OUTER RADIUS OF THE THROUGH TRAVEL LANES.

P:\31653-000\31653.dwg; 2/2/2015 12:00:45 PM

**DELAWARE  
DEPARTMENT OF TRANSPORTATION**

ADDENDUMS / REVISIONS



**US 301 &  
SR 1 INTERCHANGE**

CONTRACT	BRIDGE NO.
T200911302	DESIGNED BY: NSP
COUNTY	CHECKED BY: BRT
NEW CASTLE	

**PAVEMENT JOINT  
LAYOUT**

EX-01
SHEET NO.
72
TOTAL SHTS.
491

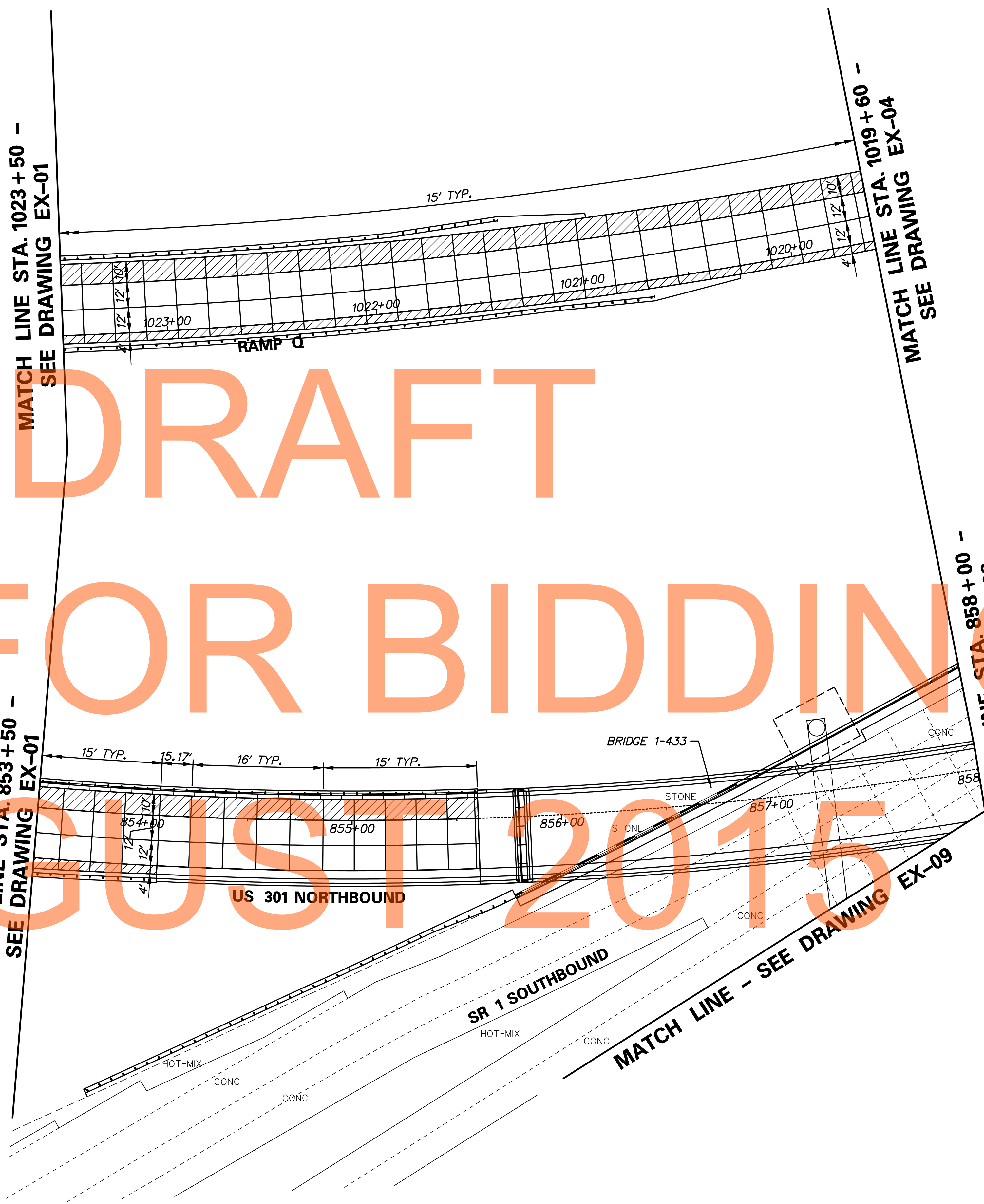
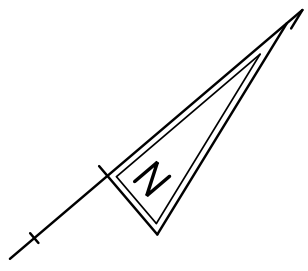

DRAFT  
NOT FOR BIDDING  
AUGUST 2015

AREA NOT SUBJECT TO IRI TESTING PER ITEM 501506 - RIDE QUALITY OF PORTLAND CEMENT CONCRETE PAVEMENT

- NOTES:**
1. JOINT LAYOUT AS SHOWN ON THE PLANS IS GRAPHICAL AND IT IS THE RESPONSIBILITY OF THE CONTRACTOR TO CONSTRUCT THE JOINTS ACCORDING TO THE STANDARD DETAILS AND THESE GENERAL NOTES.
  2. TYPICAL TRANSVERSE JOINT SPACING IS 15'.
  3. THE MAXIMUM SLAB WIDTH IS 14' UNLESS OTHERWISE NOTED ON THE PLANS OR APPROVED BY THE ENGINEER.
  4. THE MINIMUM SLAB WIDTH IS 4'.
  5. THE MINIMUM TRANSVERSE JOINT SPACING IS 12'. THE MAXIMUM TRANSVERSE SPACING IS 17'. MAXIMUM AND MINIMUM SPACING ON CURVES SHALL BE MEASURED ALONG THE LONGEST CHORD. THE MAXIMUM AND MINIMUM SPACING FOR CURVES ON THE US 301 MAINLINE SHOULD BE CALCULATED FOR FUTURE LANE EXPANSION INTO THE MEDIAN WHERE APPLICABLE.
  6. PAVEMENT CROSS SLOPES AND TRANSITION LENGTHS SHALL BE ADJUSTED AS NEEDED PER LOCATION AND TO MEET DESIGN CRITERIA.
  7. IN CURVED SECTIONS, SLAB DIMENSIONS ARE PROVIDED ALONG THE OUTER RADIUS OF THE THROUGH TRAVEL LANES.

P:\31653-000\concrete\p\cead\EX002\1301\_1B.dgn 2/27/2015 12:00:06 PM



ADDENDUMS / REVISIONS

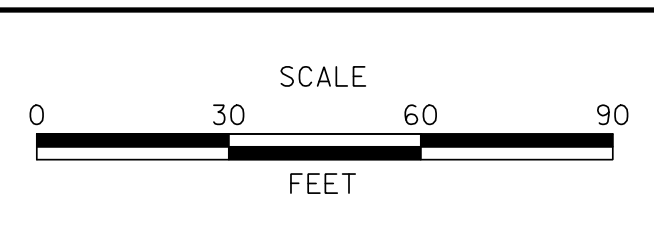



**US 301 &  
SR 1 INTERCHANGE**

CONTRACT T200911302	BRIDGE NO. 
COUNTY NEW CASTLE	DESIGNED BY: NSP
	CHECKED BY: BRT

<b>PAVEMENT JOINT LAYOUT</b>
SHEET NO. 73
TOTAL SHTS. 491

EX-02
SHEET NO. 73
TOTAL SHTS. 491

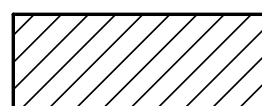

-  AREA NOT SUBJECT TO IRITESTING PER ITEM 501506 - RIDE QUALITY OF PORTLAND CEMENT CONCRETE PAVEMENT
-  JOINTS PERPENDICULAR TO US 301 NB BASELINE
-  JOINTS PERPENDICULAR TO RAMP R BASELINE

- NOTES:**
- JOINT LAYOUT AS SHOWN ON THE PLANS IS GRAPHICAL AND IT IS THE RESPONSIBILITY OF THE CONTRACTOR TO CONSTRUCT THE JOINTS ACCORDING TO THE STANDARD DETAILS AND THESE GENERAL NOTES.
  - TYPICAL TRANSVERSE JOINT SPACING IS 15'.
  - THE MAXIMUM SLAB WIDTH IS 14' UNLESS OTHERWISE NOTED ON THE PLANS OR APPROVED BY THE ENGINEER.
  - THE MINIMUM SLAB WIDTH IS 4'.
  - THE MINIMUM TRANSVERSE JOINT SPACING IS 12'. THE MAXIMUM TRANSVERSE SPACING IS 17'. MAXIMUM AND MINIMUM SPACING ON CURVES SHALL BE MEASURED ALONG THE LONGEST CHORD. THE MAXIMUM AND MINIMUM SPACING FOR CURVES ON THE US 301 MAINLINE SHOULD BE CALCULATED FOR FUTURE LANE EXPANSION INTO THE MEDIAN WHERE APPLICABLE.
  - PAVEMENT CROSS SLOPES AND TRANSITION LENGTHS SHALL BE ADJUSTED AS NEEDED PER LOCATION AND TO MEET DESIGN CRITERIA.
  - IN CURVED SECTIONS, SLAB DIMENSIONS ARE PROVIDED ALONG THE OUTER RADIUS OF THE THROUGH TRAVEL LANES.
  - NO P.C.C. PAVEMENT CONSTRUCTION ON US 13.

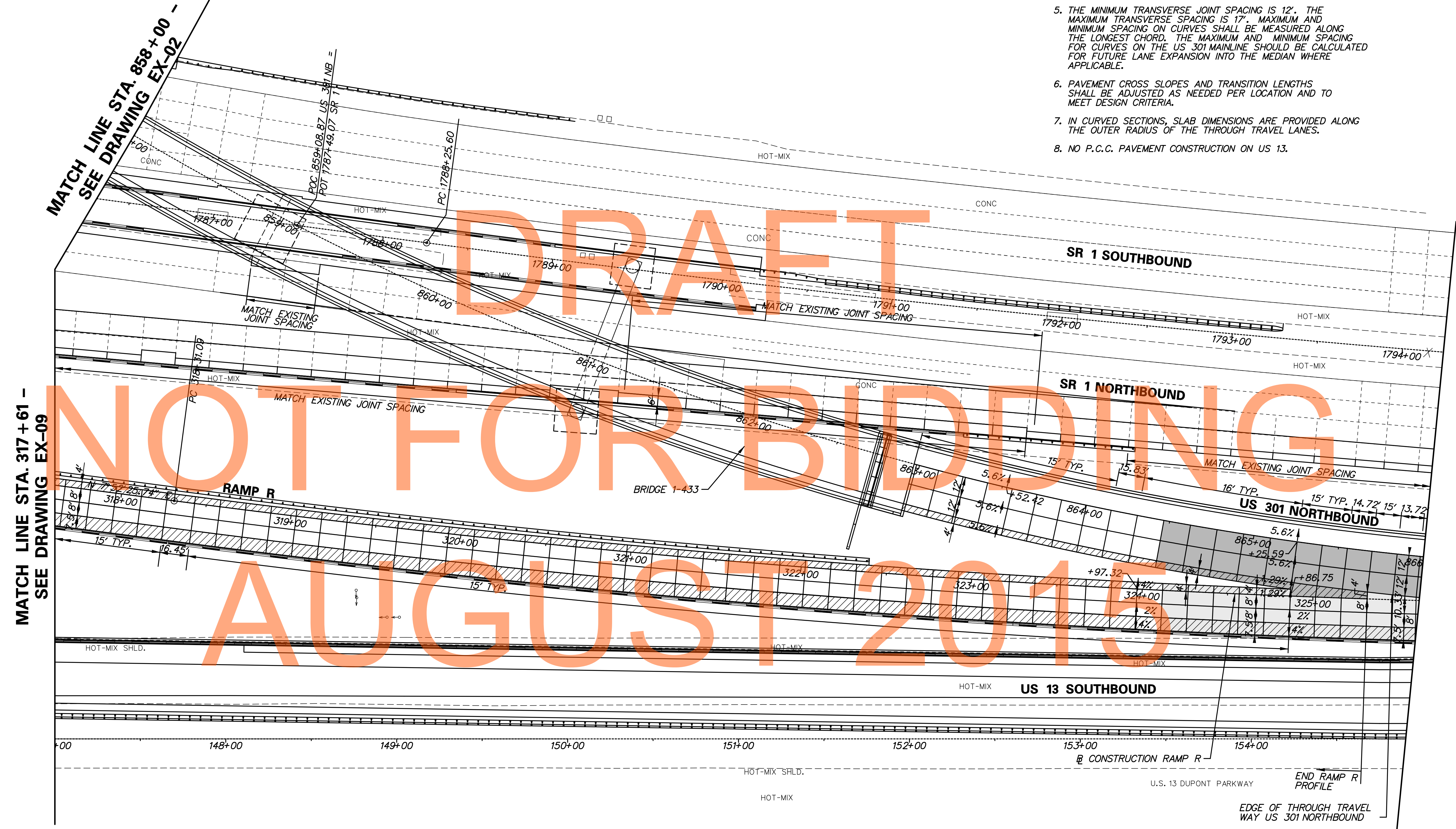
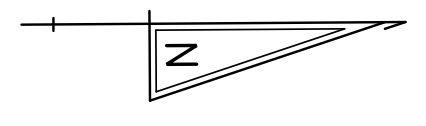

MATCH LINE STA. 317+61 - SEE DRAWING EX-09

MATCH LINE STA. 858+00 - SEE DRAWING EX-02

DRAFT  
NOT FOR BIDDING  
AUGUST 2015

P:\3653-000\contract\1b\card\EX0030301\_1B.dgn 2/2/2015 12:11:00 PM



ADDENDUMS / REVISIONS	

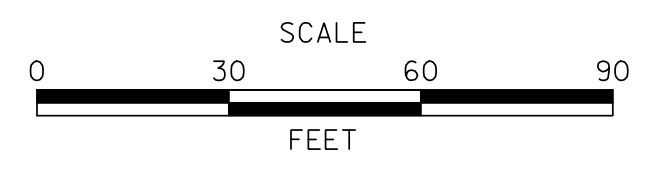

**US 301 &  
SR 1 INTERCHANGE**

CONTRACT T200911302	BRIDGE NO.
COUNTY NEW CASTLE	DESIGNED BY: NSP
	CHECKED BY: BRT

<b>PAVEMENT JOINT LAYOUT</b>	
SHEET NO.	EX-03
TOTAL SHTS.	491



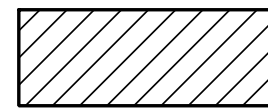

AREA NOT SUBJECT TO IRI TESTING  
PER ITEM 501506 - RIDE QUALITY OF  
PORTLAND CEMENT CONCRETE PAVEMENT

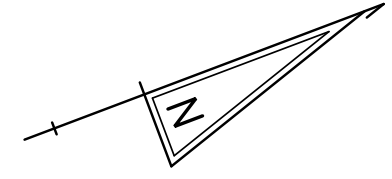

**NOTES:**

1. JOINT LAYOUT AS SHOWN ON THE PLANS IS GRAPHICAL AND IT IS THE RESPONSIBILITY OF THE CONTRACTOR TO CONSTRUCT THE JOINTS ACCORDING TO THE STANDARD DETAILS AND THESE GENERAL NOTES.
2. TYPICAL TRANSVERSE JOINT SPACING IS 15'.
3. THE MAXIMUM SLAB WIDTH IS 14' UNLESS OTHERWISE NOTED ON THE PLANS OR APPROVED BY THE ENGINEER.
4. THE MINIMUM SLAB WIDTH IS 4'.
5. THE MINIMUM TRANSVERSE JOINT SPACING IS 12'. THE MAXIMUM TRANSVERSE SPACING IS 17'. MAXIMUM AND MINIMUM SPACING ON CURVES SHALL BE MEASURED ALONG THE LONGEST CHORD. THE MAXIMUM AND MINIMUM SPACING FOR CURVES ON THE US 301 MAINLINE SHOULD BE CALCULATED FOR FUTURE LANE EXPANSION INTO THE MEDIAN WHERE APPLICABLE.
6. PAVEMENT CROSS SLOPES AND TRANSITION LENGTHS SHALL BE ADJUSTED AS NEEDED PER LOCATION AND TO MEET DESIGN CRITERIA.
7. IN CURVED SECTIONS, SLAB DIMENSIONS ARE PROVIDED ALONG THE OUTER RADIUS OF THE THROUGH TRAVEL LANES.



\\p0653-000\contract\lb\cead\EX004\1301\_IB.dgn  
2/2/2015 12:11:18 PM



ADDENDUMS / REVISIONS

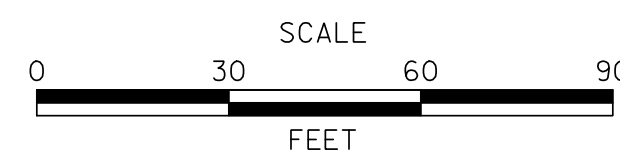

**US 301 &  
SR 1 INTERCHANGE**

CONTRACT	BRIDGE NO.
T200911302	DESIGNED BY: NSP
COUNTY	CHECKED BY: BRT
NEW CASTLE	

**PAVEMENT JOINT  
LAYOUT**

EX-04
SHEET NO.
75
TOTAL SHTS.
491







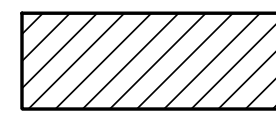

AREA NOT SUBJECT TO IRI TESTING PER ITEM 501506 - RIDE QUALITY OF PORTLAND CEMENT CONCRETE PAVEMENT

**NOTES:**

1. JOINT LAYOUT AS SHOWN ON THE PLANS IS GRAPHICAL AND IT IS THE RESPONSIBILITY OF THE CONTRACTOR TO CONSTRUCT THE JOINTS ACCORDING TO THE STANDARD DETAILS AND THESE GENERAL NOTES.
2. TYPICAL TRANSVERSE JOINT SPACING IS 15'.
3. THE MAXIMUM SLAB WIDTH IS 14' UNLESS OTHERWISE NOTED ON THE PLANS OR APPROVED BY THE ENGINEER.
4. THE MINIMUM SLAB WIDTH IS 4'.
5. THE MINIMUM TRANSVERSE JOINT SPACING IS 12'. THE MAXIMUM TRANSVERSE SPACING IS 17'. MAXIMUM AND MINIMUM SPACING ON CURVES SHALL BE MEASURED ALONG THE LONGEST CHORD. THE MAXIMUM AND MINIMUM SPACING FOR CURVES ON THE US 301 MAINLINE SHOULD BE CALCULATED FOR FUTURE LANE EXPANSION INTO THE MEDIAN WHERE APPLICABLE.
6. PAVEMENT CROSS SLOPES AND TRANSITION LENGTHS SHALL BE ADJUSTED AS NEEDED PER LOCATION AND TO MEET DESIGN CRITERIA.
7. IN CURVED SECTIONS, SLAB DIMENSIONS ARE PROVIDED ALONG THE OUTER RADIUS OF THE THROUGH TRAVEL LANES.
8. NO P.C.C. PAVEMENT CONSTRUCTION ON US 13.



MATCH LINE STA. 1802+00 - SEE DRAWING EX-05

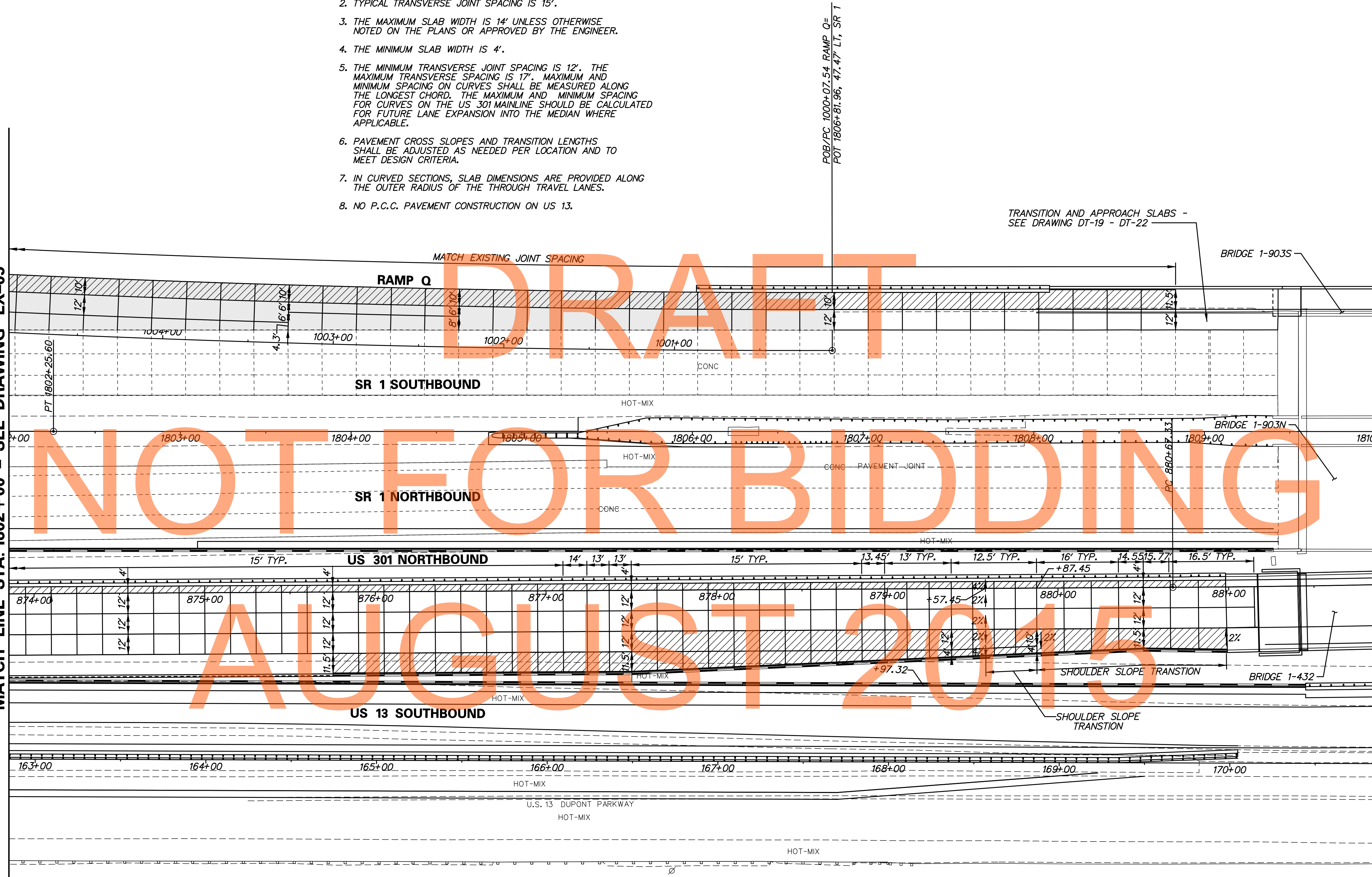

MATCH LINE STA. 1810+00 - SEE DRAWING EX-07

NOT FOR BIDDING  
AUGUST 2015

P:\31653-000\31653.dwg, 12/15/15 12:15:52 PM



ADDENDUMS / REVISIONS





**US 301 &  
SR 1 INTERCHANGE**

CONTRACT	BRIDGE NO.
T200911302	
COUNTY	DESIGNED BY: NSP
NEW CASTLE	CHECKED BY: BRT

**PAVEMENT JOINT  
LAYOUT**

EX-06
SHEET NO.
77
TOTAL SHTS.
491

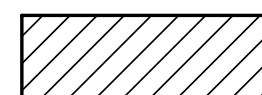

-  AREA NOT SUBJECT TO IRI TESTING PER ITEM 501506 - RIDE QUALITY OF PORTLAND CEMENT CONCRETE PAVEMENT
-  JOINTS PERPENDICULAR TO US 301 NORTHBOUND BASELINE
-  JOINTS PERPENDICULAR TO SR 1 BASELINE

- NOTES:**
1. JOINT LAYOUT AS SHOWN ON THE PLANS IS GRAPHICAL AND IT IS THE RESPONSIBILITY OF THE CONTRACTOR TO CONSTRUCT THE JOINTS ACCORDING TO THE STANDARD DETAILS AND THESE GENERAL NOTES.
  2. TYPICAL TRANSVERSE JOINT SPACING IS 15'.
  3. THE MAXIMUM SLAB WIDTH IS 14' UNLESS OTHERWISE NOTED ON THE PLANS OR APPROVED BY THE ENGINEER.
  4. THE MINIMUM SLAB WIDTH IS 4'.
  5. THE MINIMUM TRANSVERSE JOINT SPACING IS 12'. THE MAXIMUM TRANSVERSE SPACING IS 17'. MAXIMUM AND MINIMUM SPACING ON CURVES SHALL BE MEASURED ALONG THE LONGEST CHORD. THE MAXIMUM AND MINIMUM SPACING FOR CURVES ON THE US 301 MAINLINE SHOULD BE CALCULATED FOR FUTURE LANE EXPANSION INTO THE MEDIAN WHERE APPLICABLE.
  6. PAVEMENT CROSS SLOPES AND TRANSITION LENGTHS SHALL BE ADJUSTED AS NEEDED PER LOCATION AND TO MEET DESIGN CRITERIA.
  7. IN CURVED SECTIONS, SLAB DIMENSIONS ARE PROVIDED ALONG THE OUTER RADIUS OF THE THROUGH TRAVEL LANES.
  8. NO P.C.C. PAVEMENT CONSTRUCTION ON US 13.

COORDINATE LIST					
POINT NO.	STATION	OFFSET	NORTHING	EASTING	ELEVATION
80015	1815+79.76	55.00	559946.8181	590542.4968	18.26'
80016	1815+94.20	53.73	559961.3402	590538.5050	18.40'
80017	1815+94.20	55.00	559961.2607	590542.7706	18.26'
80018	1815+79.76	50.73	559976.3358	590538.7846	18.49'

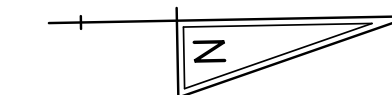

MATCH LINE STA. 1810+00 - SEE DRAWING EX-06

MATCH LINE STA. 1818+00 - SEE DRAWING EX-08

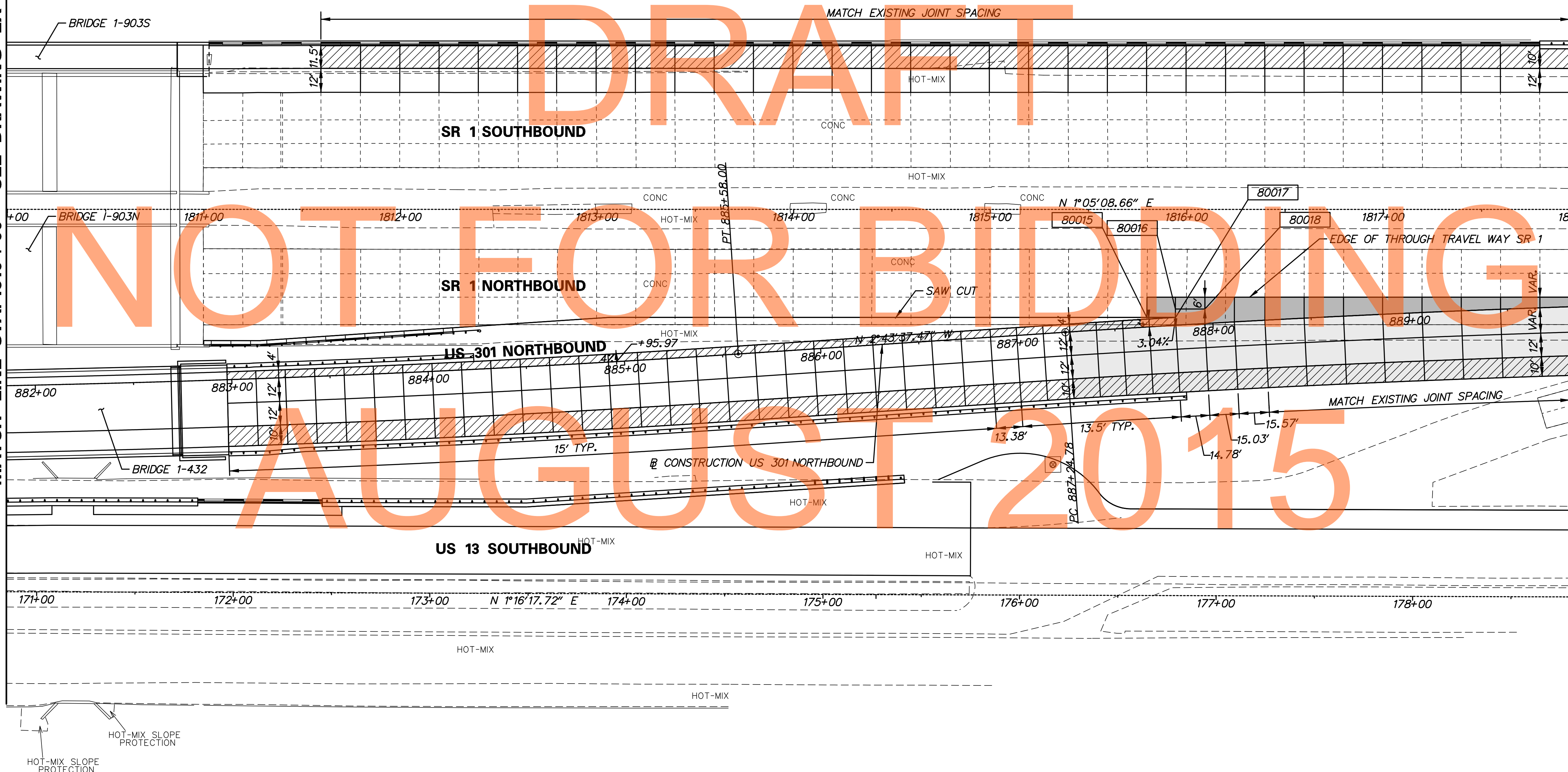

NOT FOR BIDDING

AUGUST 2015

P:\3653-000\CONTRACTS\1b\card\EX007\301\_1B.dgn 2/2/2015 12:15:28 PM



ADDENDUMS / REVISIONS





**US 301 & SR 1 INTERCHANGE**

CONTRACT	BRIDGE NO.
T200911302	DESIGNED BY: NSP
COUNTY	CHECKED BY: BRT
NEW CASTLE	

**PAVEMENT JOINT LAYOUT**

EX-07
SHEET NO.
78
TOTAL SHTS.
491

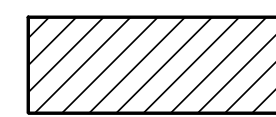

-  AREA NOT SUBJECT TO IRI TESTING PER ITEM 501506 - RIDE QUALITY OF PORTLAND CEMENT CONCRETE PAVEMENT
-  JOINTS PERPENDICULAR TO US 301 NORTHBOUND BASELINE
-  JOINTS PERPENDICULAR TO SR 1 BASELINE

- NOTES:**
1. JOINT LAYOUT AS SHOWN ON THE PLANS IS GRAPHICAL AND IT IS THE RESPONSIBILITY OF THE CONTRACTOR TO CONSTRUCT THE JOINTS ACCORDING TO THE STANDARD DETAILS AND THESE GENERAL NOTES.
  2. TYPICAL TRANSVERSE JOINT SPACING IS 15'.
  3. THE MAXIMUM SLAB WIDTH IS 14' UNLESS OTHERWISE NOTED ON THE PLANS OR APPROVED BY THE ENGINEER.
  4. THE MINIMUM SLAB WIDTH IS 4'.
  5. THE MINIMUM TRANSVERSE JOINT SPACING IS 12'. THE MAXIMUM TRANSVERSE SPACING IS 17'. MAXIMUM AND MINIMUM SPACING ON CURVES SHALL BE MEASURED ALONG THE LONGEST CHORD. THE MAXIMUM AND MINIMUM SPACING FOR CURVES ON THE US 301 MAINLINE SHOULD BE CALCULATED FOR FUTURE LANE EXPANSION INTO THE MEDIAN WHERE APPLICABLE.
  6. PAVEMENT CROSS SLOPES AND TRANSITION LENGTHS SHALL BE ADJUSTED AS NEEDED PER LOCATION AND TO MEET DESIGN CRITERIA.
  7. IN CURVED SECTIONS, SLAB DIMENSIONS ARE PROVIDED ALONG THE OUTER RADIUS OF THE THROUGH TRAVEL LANES.
  8. NO P.C.C. PAVEMENT CONSTRUCTION ON US 13.

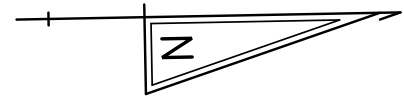

MATCH LINE STA. 1818+00 - SEE DRAWING EX-07

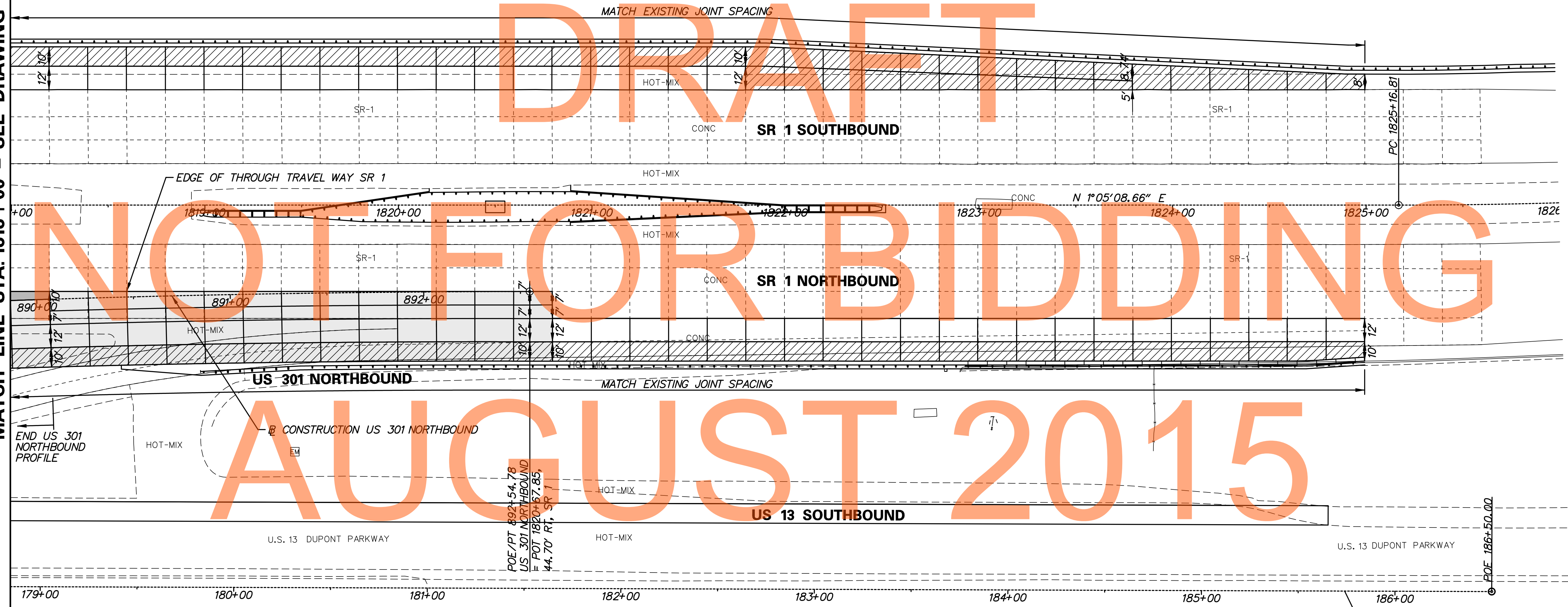

p:\1653-000\scen\pact\lb\cead\EX008U301\_1B.dgn 2/2/2015 12:15:51 PM



ADDENDUMS / REVISIONS	



**US 301 &  
SR 1 INTERCHANGE**

CONTRACT T200911302	BRIDGE NO.
COUNTY NEW CASTLE	DESIGNED BY: NSP
	CHECKED BY: BRT

<b>PAVEMENT JOINT LAYOUT</b>

EX-08
SHEET NO.
79
TOTAL SHTS.
491



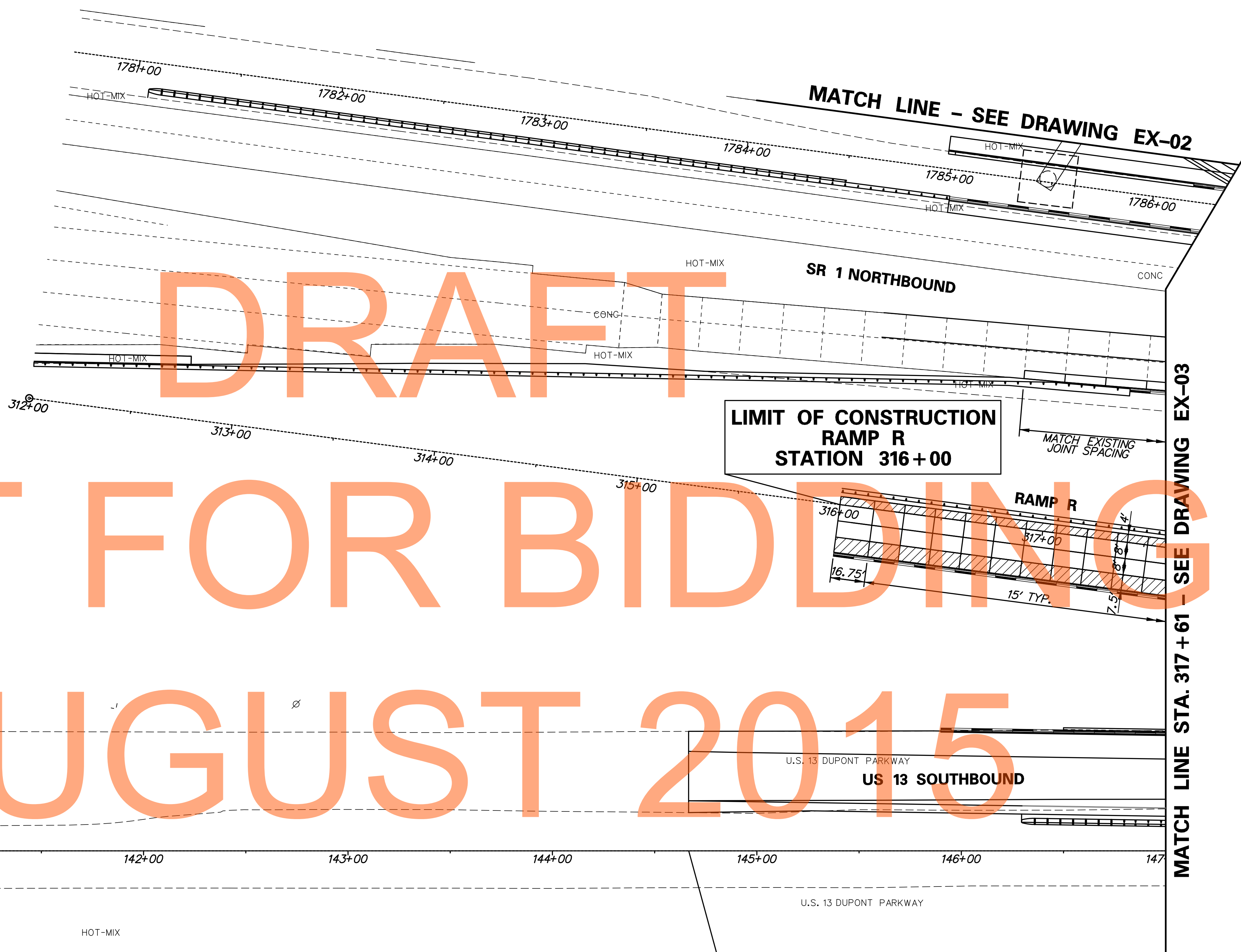
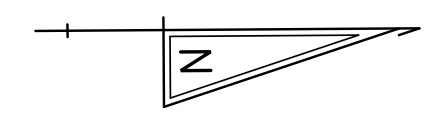

DRAFT  
NOT FOR BIDDING  
AUGUST 2015

AREA NOT SUBJECT TO IRI TESTING PER ITEM 501506 - RIDE QUALITY OF PORTLAND CEMENT CONCRETE PAVEMENT

- NOTES:**
1. JOINT LAYOUT AS SHOWN ON THE PLANS IS GRAPHICAL AND IT IS THE RESPONSIBILITY OF THE CONTRACTOR TO CONSTRUCT THE JOINTS ACCORDING TO THE STANDARD DETAILS AND THESE GENERAL NOTES.
  2. TYPICAL TRANSVERSE JOINT SPACING IS 15'.
  3. THE MAXIMUM SLAB WIDTH IS 14' UNLESS OTHERWISE NOTED ON THE PLANS OR APPROVED BY THE ENGINEER.
  4. THE MINIMUM SLAB WIDTH IS 4'.
  5. THE MINIMUM TRANSVERSE JOINT SPACING IS 12'. THE MAXIMUM TRANSVERSE SPACING IS 17'. MAXIMUM AND MINIMUM SPACING ON CURVES SHALL BE MEASURED ALONG THE LONGEST CHORD. THE MAXIMUM AND MINIMUM SPACING FOR CURVES ON THE US 301 MAINLINE SHOULD BE CALCULATED FOR FUTURE LANE EXPANSION INTO THE MEDIAN WHERE APPLICABLE.
  6. PAVEMENT CROSS SLOPES AND TRANSITION LENGTHS SHALL BE ADJUSTED AS NEEDED PER LOCATION AND TO MEET DESIGN CRITERIA.
  7. IN CURVED SECTIONS, SLAB DIMENSIONS ARE PROVIDED ALONG THE OUTER RADIUS OF THE THROUGH TRAVEL LANES.
  8. NO P.C.C. PAVEMENT CONSTRUCTION ON US 13.

**LIMIT OF CONSTRUCTION  
RAMP R  
STATION 316+00**

**LIMIT OF CONSTRUCTION  
US 13  
STATION 144+67**

MATCH LINE STA. 317+61 - SEE DRAWING EX-03

p:\31653-000\stn\fig\051b\cead\EX009U301\_1B.dgn 2/2/2015 12:15:28 PM



ADDENDUMS / REVISIONS	

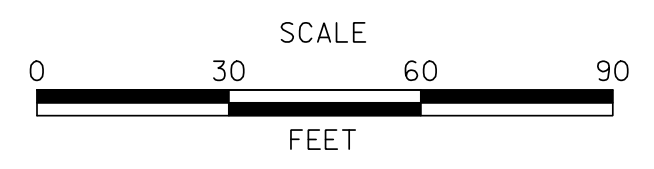

**US 301 &  
SR 1 INTERCHANGE**

CONTRACT T200911302	BRIDGE NO.	
COUNTY NEW CASTLE	DESIGNED BY: NSP	
	CHECKED BY: BRT	

<b>PAVEMENT JOINT LAYOUT</b>
SHEET NO. 80
TOTAL SHTS. 491

EX-09



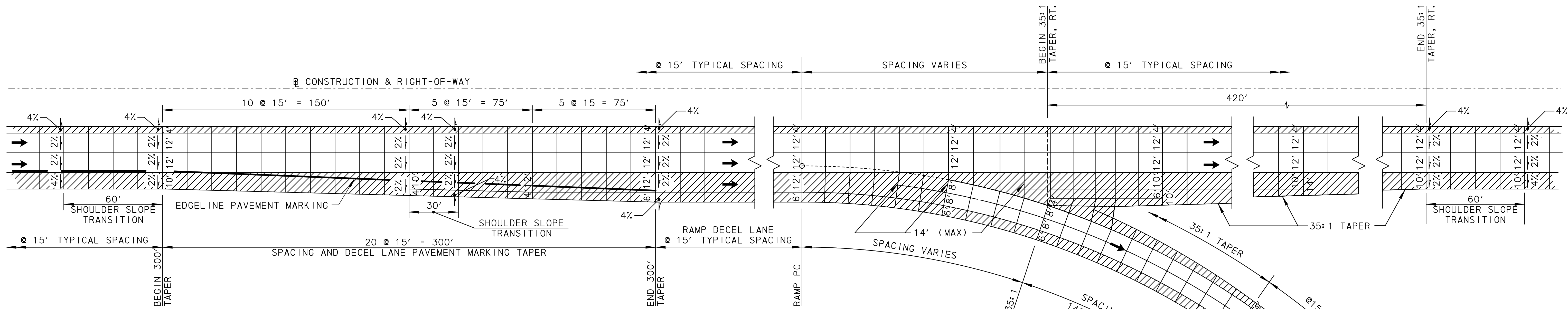

DRAFT

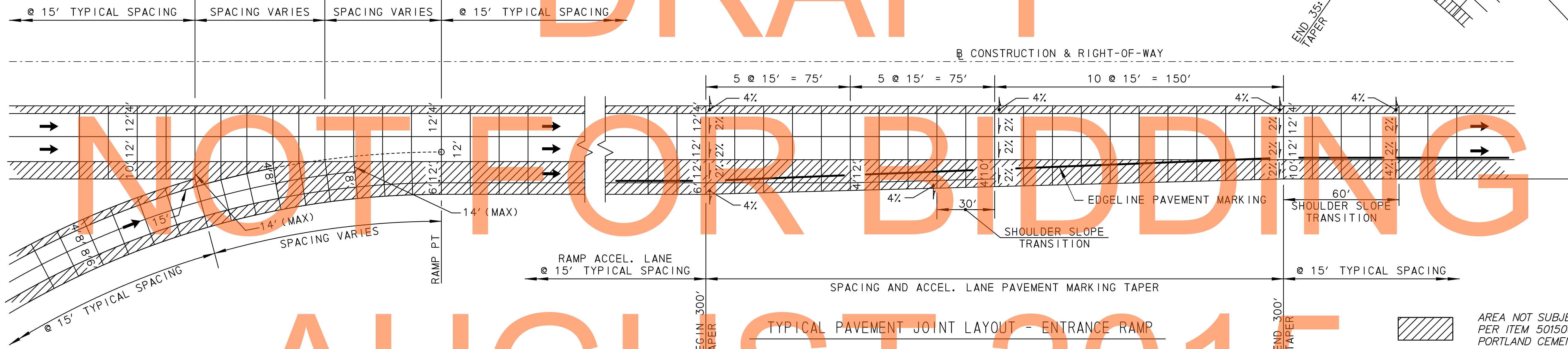

AUGUST 2015

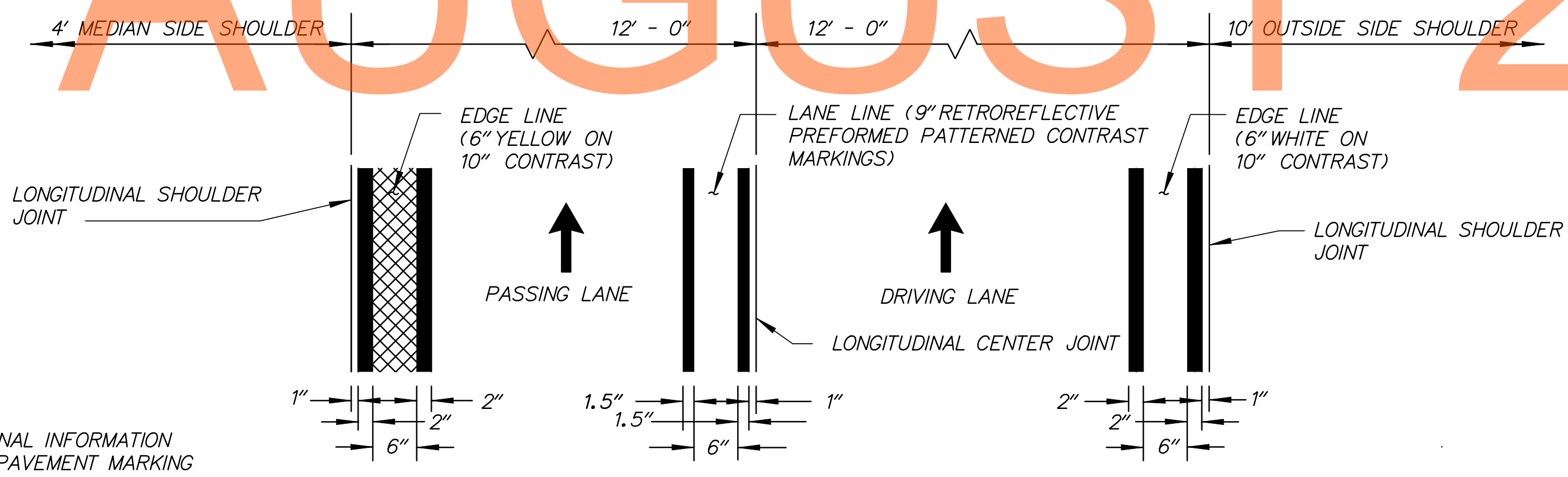

NOTE:  
FOR ADDITIONAL INFORMATION REGARDING PAVEMENT MARKING AND RECESSED PAVEMENT MARKER LAYOUT SEE THE DELAWARE MUTCD.

TYPICAL PAVEMENT MARKING LAYOUT  
NTS

- GENERAL NOTES**
1. JOINT LAYOUT AS SHOWN ON THE PLANS IS GRAPHICAL AND IT IS THE RESPONSIBILITY OF THE CONTRACTOR TO CONSTRUCT THE JOINTS ACCORDING TO THE STANDARD DETAILS AND THESE GENERAL NOTES.
  2. TYPICAL TRANSVERSE JOINT SPACING IS 15'.
  3. THE MAXIMUM SLAB WIDTH IS 14' UNLESS OTHERWISE NOTED ON THE PLANS OR APPROVED BY THE ENGINEER.
  4. THE MINIMUM SLAB WIDTH IS 4'.
  5. THE MINIMUM TRANSVERSE JOINT SPACING IS 12'. THE MAXIMUM TRANSVERSE SPACING IS 17'. SPACING ON CURVES SHALL BE MEASURED ALONG THE LONGEST CHORD. THE MAXIMUM AND MINIMUM SPACING FOR CURVES ON THE US 301 MAINLINE SHOULD BE CALCULATED FOR FUTURE LANE EXPANSION INTO THE MEDIAN WHERE APPLICABLE.
  6. PAVEMENT CROSS SLOPES AND TRANSITION LENGTHS SHALL BE ADJUSTED AS NEEDED PER LOCATION AND TO MEET DESIGN CRITERIA.

AREA NOT SUBJECT TO IRITESTING PER ITEM 501506 - RIDE QUALITY OF PORTLAND CEMENT CONCRETE PAVEMENT

p:\3653-000\contract\p\card\EX0100301.LB.dgn  
 2/2/2015 12:24:54 PM

ADDENDUMS / REVISIONS



CONTRACT T200911302	BRIDGE NO.
COUNTY NEW CASTLE	DESIGNED BY: SKS
	CHECKED BY: AKM

<b>PAVEMENT JOINT LAYOUT DETAILS</b>	SHEET NO. 81
	TOTAL SHTS. 491