

EDGELINE RUMBLE STRIPS DETAIL

NOT TO SCALE

- NOTES:**
- ALL WORK REQUIRED TO COMPLETE THE INSTALLATION OF ROADWAY EDGELINE RUMBLE STRIPS SHALL BE INCIDENTAL TO ITEM 760016 - RUMBLE STRIPS, HOT MIX AND/OR ITEM 760017 - RUMBLE STRIPS, CONCRETE.
 - RUMBLE STRIPS END 50' PRIOR TO PHYSICAL GORE.
 - ROADWAY EDGELINE RUMBLE STRIPS SHALL BE INSTALLED ALONG SHOULDERS, AS PER THIS DETAIL, AT THE FOLLOWING STATIONS:

STATION 854+05 TO STATION 855+59 LT., US 301 NB	STATION 848+00 TO STATION 854+05 LT. & RT., US 301 NB
STATION 872+00 TO STATION 875+75 LT., US 301 NB	STATION 875+75 TO STATION 881+20 LT. & RT., US 301 NB
STATION 862+98 TO STATION 864+72 RT., US 301 NB	STATION 882+94 TO STATION 887+78 LT. & RT., US 301 NB
STATION 887+78 TO STATION 892+55 RT., US 301 NB	STATION 1010+95 TO STATION 1028+50 LT. & RT., RAMP Q
STATION 1000+08 TO STATION 1010+95 RT., RAMP Q	STATION 316+00 TO STATION 324+73 LT. & RT., RAMP R
STATION 324+73 TO STATION 326+15 RT., RAMP R	STATION 1783+67 TO STATION 1805+50 RT., SR 1
STATION 1785+74 TO STATION 1786+10 LT., SR 1	STATION 1785+01 TO STATION 1790+28 RT., SR 1 (MEDIAN)
STATION 1801+25 TO STATION 1809+43 LT., SR 1 (MEDIAN)	STATION 1808+75 TO STATION 1809+43 RT., SR 1 (MEDIAN)
STATION 1806+82 TO STATION 1808+83 LT., SR 1	STATION 1811+00 TO STATION 1831+25 RT., SR 1 (MEDIAN)
STATION 1811+00 TO STATION 1833+75 LT., SR 1 (MEDIAN)	STATION 1811+00 TO STATION 1815+94 RT., SR 1
STATION 1811+60 TO STATION 1820+68 LT., SR 1	STATION 1820+68 TO STATION 1825+00 LT. & RT., SR 1
 - EDGELINE RUMBLE STRIPS SHALL ALSO BE INSTALLED ALONG THE SHOULDERS OF THE BR1-433 MOMENT SLABS, APPROACH SLABS AND DECK SLAB AND RW1-3 AND RW1-3R MOMENT SLABS. RUMBLE STRIPS IN THESE LOCATIONS SHALL HAVE A 16" MAX. RADIUS AND A 3/8" MAXIMUM DEPTH. ALL WORK REQUIRED TO COMPLETE THE INSTALLATION OF EDGELINE RUMBLE STRIPS AT THESE LOCATIONS SHALL BE INCIDENTAL TO ITEM 760015 - RUMBLE STRIPS, CONCRETE, SHALLOW DEPTH, BRIDGE AND RETAINING WALL PAYMENT ITEMS.
 - EDGELINE RUMBLE STRIPS SHALL ALSO BE INSTALLED ALONG THE INSIDE AND OUTSIDE SHOULDERS OF US 13 AND HAVE A 3/8" MAXIMUM DEPTH AND BE MEASURED LONGITUDINALLY PER LINEAR FOOT, PLUS THE 12" OPENING EVERY 40". RUMBLE STRIPS SHALL BE INSTALLED IN ACCORDANCE WITH ITEM 760012 - RUMBLE STRIPS, BIKE-FRIENDLY, HOT-MIX AT THE FOLLOWING LOCATIONS:

STATION 144+67 TO STATION 170+05 RT., US 13 INSIDE SHOULDER	
STATION 144+67 TO STATION 175+02 RT., US 13 OUTSIDE SHOULDER	

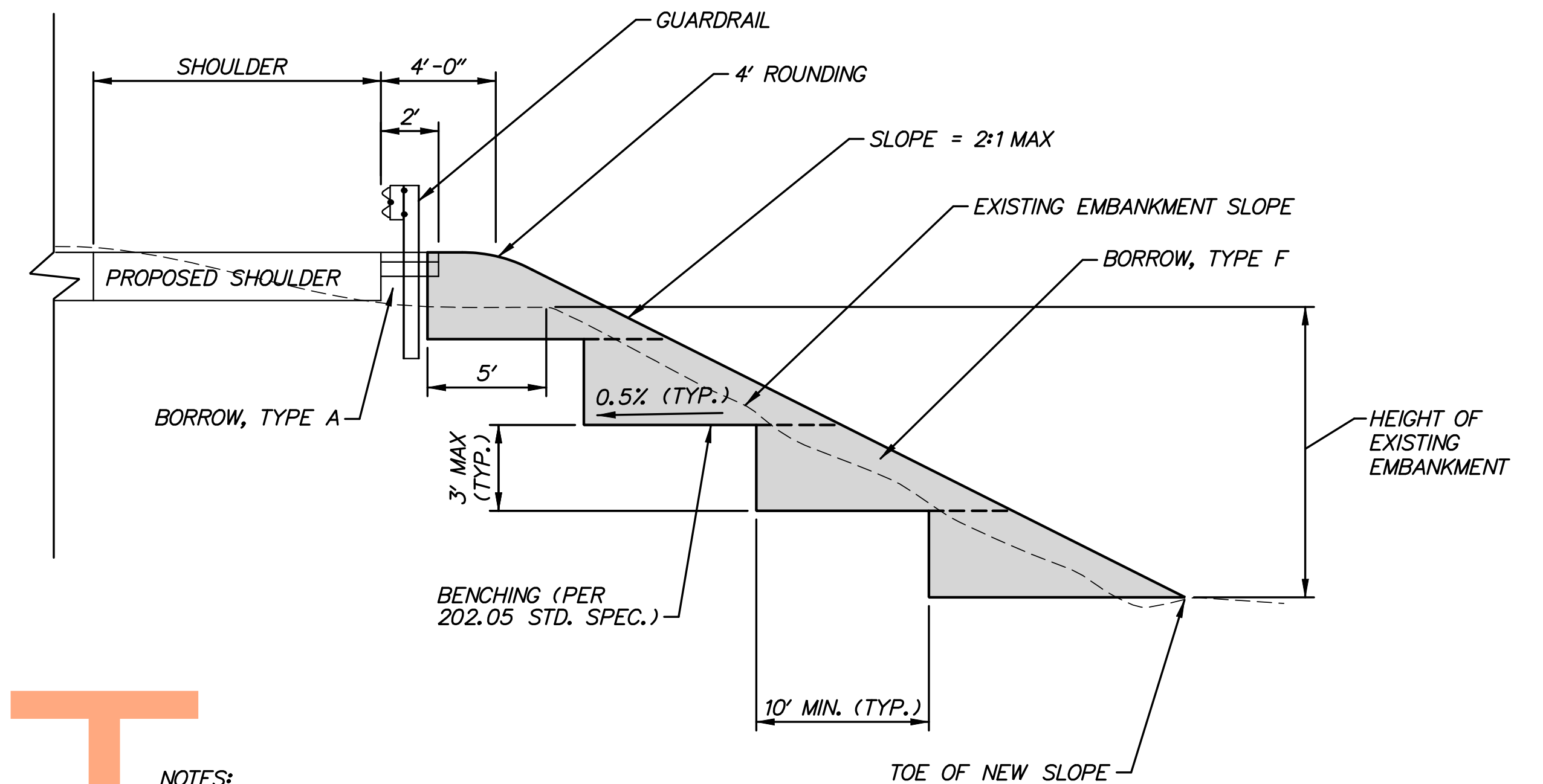

BENCHING DETAIL

NOT TO SCALE

- NOTES:**
- BENCHING SHALL CONFORM TO THIS DETAIL AT ALL LOCATIONS WHERE EXISTING EMBANKMENTS WITH A SLOPE 4:1 OR STEEPER, AND A HEIGHT OF 3' OR MORE, ARE WIDENED.

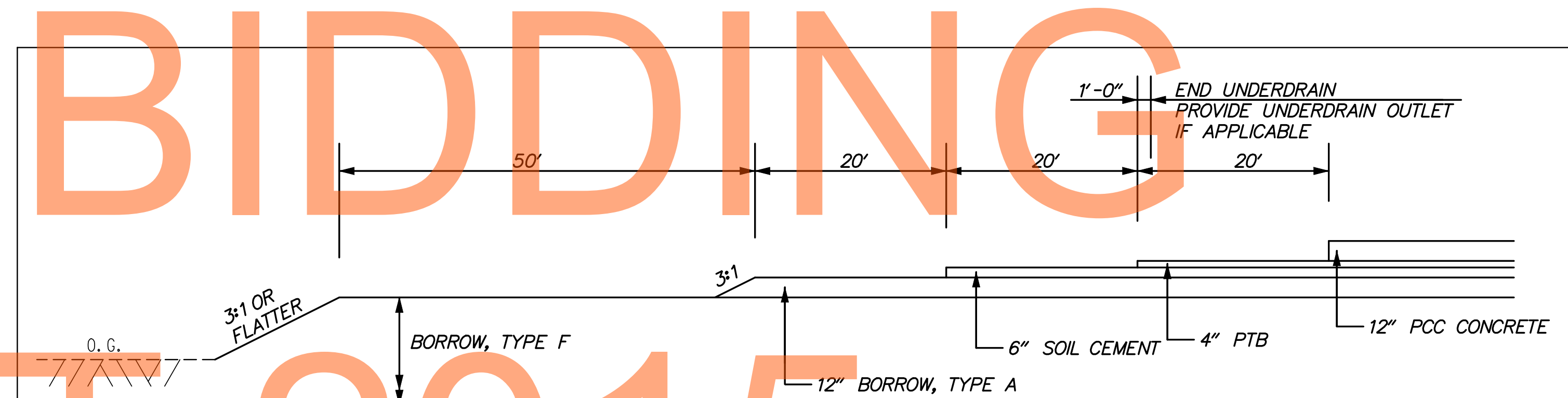

PAVEMENT DETAIL AT LIMIT OF CONSTRUCTION

NOT TO SCALE

- NOTES:**
- THIS DETAIL SHALL APPLY TO PAVEMENT CONSTRUCTED BY THE FIRST CONTRACTOR TO PERFORM WORK IN THIS AREA. SELECTION OF WHICH CONTRACT WILL CONSTRUCT THIS DETAIL WILL BE BASED UPON FIELD CONDITIONS AND WILL BE AT THE DIRECTION OF THE ENGINEER. PAYMENT SHALL BE MADE UNDER THE APPLICABLE CONTRACT PAY ITEMS.
 - THE FIRST CONTRACTOR SHALL COVER THE EXPOSED PERMEABLE TREATED BASE COURSE AND SOIL CEMENT BASE COURSE, INCLUDING SIDES AND ENDS, WITH POLYETHYLENE SHEETING, PROPERLY ANCHORED AND LAPPED AT LEAST 18". NO CONSTRUCTION TRAFFIC OF ANY KIND SHALL BE PERMITTED TO TRAVERSE OVER THE PTB OR SOIL CEMENT AT ANY TIME, EITHER COVERED OR UNCOVERED WITH POLYETHYLENE, EXCEPT FOR NECESSARY EQUIPMENT UTILIZED DURING PAVING OPERATIONS. ALL COSTS FOR FURNISHING, INSTALLING AND MAINTAINING THE POLYETHYLENE SHALL BE INCIDENTAL TO THE UNIT PRICE BID FOR THE PTB AND SOIL CEMENT BASE COURSE PAY ITEMS.
 - THE SECOND CONTRACTOR TO PERFORM OPERATIONS IN THIS AREA SHALL REMOVE AND PROPERLY DISPOSE OF THE POLYETHYLENE AND ANCHORING IMMEDIATELY PRIOR TO BEGINNING PAVEMENT OPERATIONS WITH ALL COSTS INCIDENTAL TO THE UNIT PRICE BID FOR THE PTB AND SOIL CEMENT BASE COURSE PAY ITEMS.
 - THE SECOND CONTRACTOR SHALL ALSO SAW CUT THE ENDS OF THE PTB AND SOIL CEMENT BASE COURSE A MINIMUM OF 6" FROM THE END FINISHED BY THE FIRST CONTRACTOR OR AS DIRECTED BY THE ENGINEER. COSTS FOR SAWCUTTING THE PTB SHALL BE MEASURED FOR PAYMENT UNDER ITEM 762001 SAWCUTTING, HOT MIX. COSTS FOR SAWCUTTING THE SOIL CEMENT BASE COURSE SHALL BE MEASURED FOR PAYMENT UNDER ITEM 762002 SAWCUTTING, CONCRETE, FULL DEPTH.
 - THE FIRST CONTRACTOR SHALL CONSTRUCT AND MAINTAIN EDGE BERMS AND TEMPORARY SLOPE DRAINS ALONG THE TOP OF ALL SIDE AND END SLOPES PER THE INCREMENTAL STABILIZATION DETAILS (STANDARD NO. E-1).
 - THE SECOND CONTRACTOR SHALL REMOVE THE EDGE BERMS AND TEMPORARY SLOPE DRAINS WITH ALL COSTS INCIDENTAL TO ITEM 202000.

DRAFT FOR BIDDING AUGUST 2015

P:\31653-000\31653.dwg, 12/21/15 12:22:52 PM

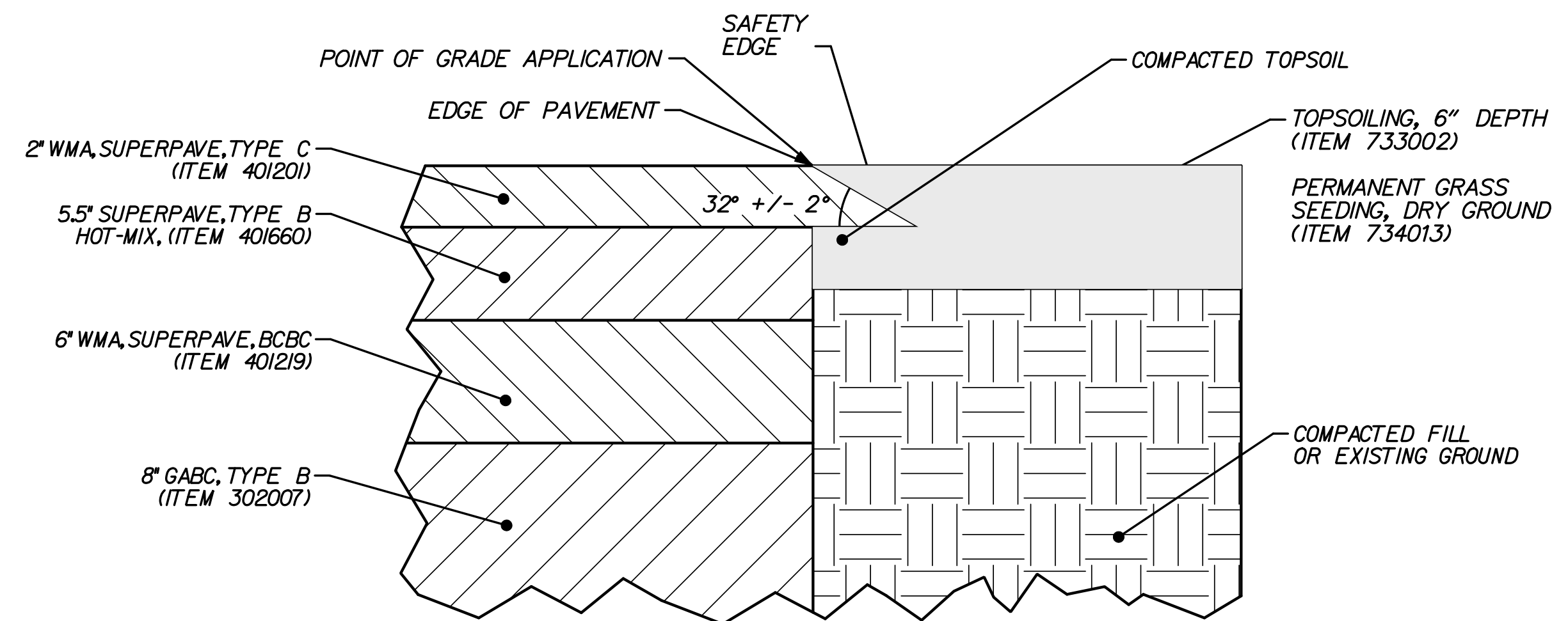

- NOTE:**
1. FOR ADDITIONAL INFORMATION, SEE ITEM 401572 SAFETY EDGE FOR ROADWAY PAVEMENT.
 2. THE SAFETY EDGE SHALL NOT BE CONSTRUCTED ADJACENT TO OTHER PAVEMENTS, CURB, CURB & GUTTER, CONCRETE SAFETY BARRIER OR MAINTENANCE PAVEMENT UNDER GUARDRAIL. THE CONTRACTOR SHALL STAKE OUT THE LIMITS OF THE AREAS NOT TO RECEIVE THE SAFETY EDGE FOR APPROVAL BY THE ENGINEER PRIOR TO BEGINNING PAVEMENT OPERATIONS.
 3. IN BITUMINOUS CONCRETE PAVEMENT SECTIONS, PRIOR TO THE CONSTRUCTION OF THE SAFETY EDGE IN OVERLAY SECTIONS AND MILL/OVERLAY SECTIONS, THE EXISTING TOPSOIL OR IN-SITU MATERIAL AT THE EDGE OF PAVEMENT SHALL BE COMPACTED SO THAT IT IS LEVEL WITH THE BOTTOM OF THE FINAL SURFACE LAYER PRIOR TO PLACING THE FINAL SURFACE OVERLAY. AFTER THE FINAL SURFACE OVERLAY IS PLACED, TOPSOIL SHALL BE PLACED TO THE TOP OF THE FINAL SURFACE OVERLAY.
 4. IN BITUMINOUS CONCRETE PAVEMENT SECTIONS WHERE FULL DEPTH TOPSOIL IS PROPOSED TO BE PLACED ADJACENT TO THE EDGE OF PAVEMENT, THE TOPSOIL SHALL BE PLACED AND COMPACTED ALONG THE PAVEMENT EDGE TO THAT IS IT LEVEL WITH THE BOTTOM OF THE FINAL SURFACE LAYER PRIOR TO PLACING THE FINAL SURFACE OVERLAY. AFTER THE FINAL SURFACE OVERLAY IS PLACED, THE TOPSOIL SHALL BE PLACED TO THE TOP OF THE FINAL SURFACE OVERLAY. ALL COSTS FOR PLACING AND COMPACTING THE TOPSOIL SHALL BE INCLUDED IN THE PRICE OF THE TOPSOIL ITEM.

SAFETY EDGE - BITUMINOUS PAVEMENT AND OVERLAYS
NOT TO SCALE

NOT FOR BIDDING

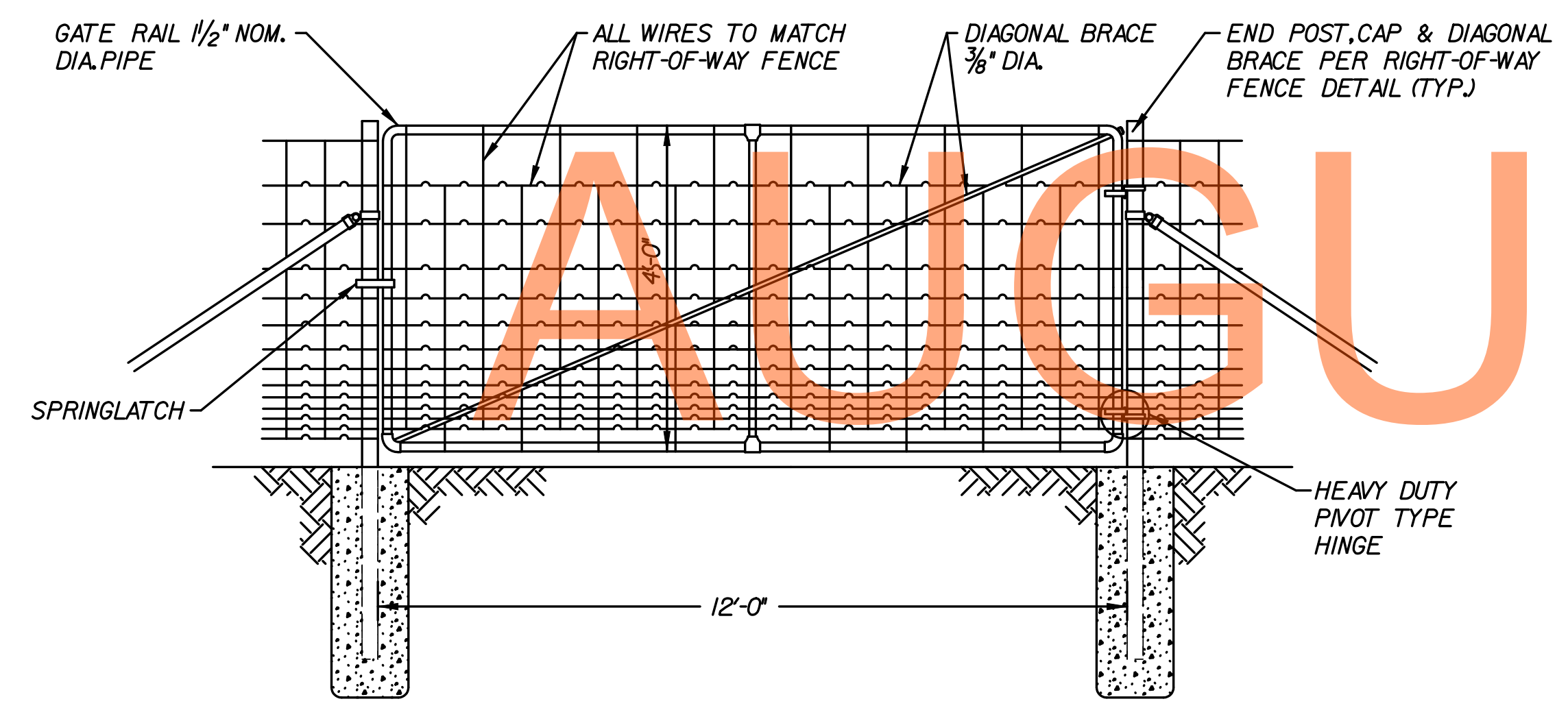

ITEM 727001 - RIGHT-OF-WAY FENCE GATE
NOT TO SCALE

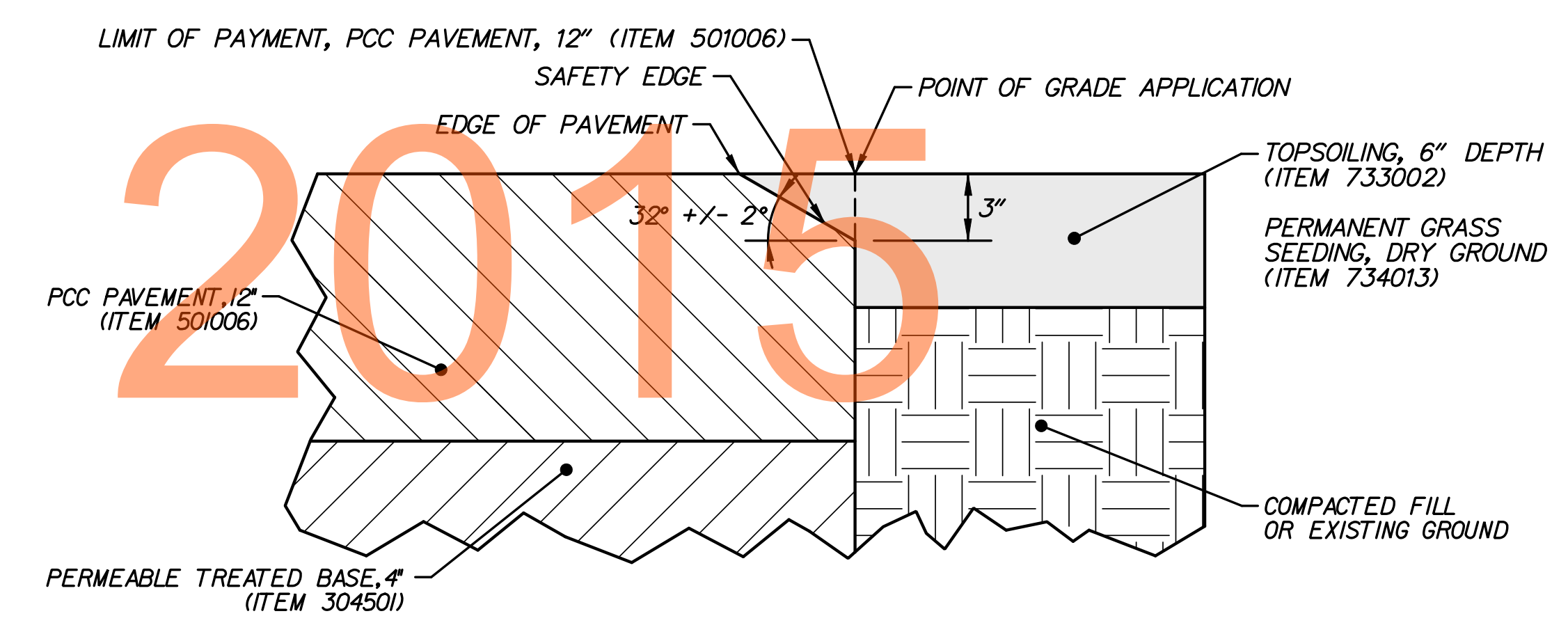

- NOTE:**
1. FOR ADDITIONAL INFORMATION, SEE ITEM 401572 SAFETY EDGE FOR ROADWAY PAVEMENT.
 2. THE SAFETY EDGE SHALL NOT BE CONSTRUCTED ADJACENT TO OTHER PAVEMENTS, CURB, CURB & GUTTER, CONCRETE SAFETY BARRIER OR MAINTENANCE PAVEMENT UNDER GUARDRAIL. THE CONTRACTOR SHALL STAKE OUT THE LIMITS OF THE AREAS NOT TO RECEIVE THE SAFETY EDGE FOR APPROVAL BY THE ENGINEER PRIOR TO BEGINNING PAVEMENT OPERATIONS.

SAFETY EDGE - CONCRETE PAVEMENT
NOT TO SCALE

P:\31653-000\CONTRACTS\1b\cead\DT002\U30_L_TB.dgn
 2/27/2015 12:12:35 PM

ADDENDUMS / REVISIONS	

NOT TO SCALE

US 301 & SR 1 INTERCHANGE

CONTRACT	BRIDGE NO.
T200911302	
COUNTY	DESIGNED BY: B.R.T.
NEW CASTLE	CHECKED BY: P.S.D.

CONSTRUCTION DETAILS

DT-02
SHEET NO.
85
TOTAL SHTS.
491

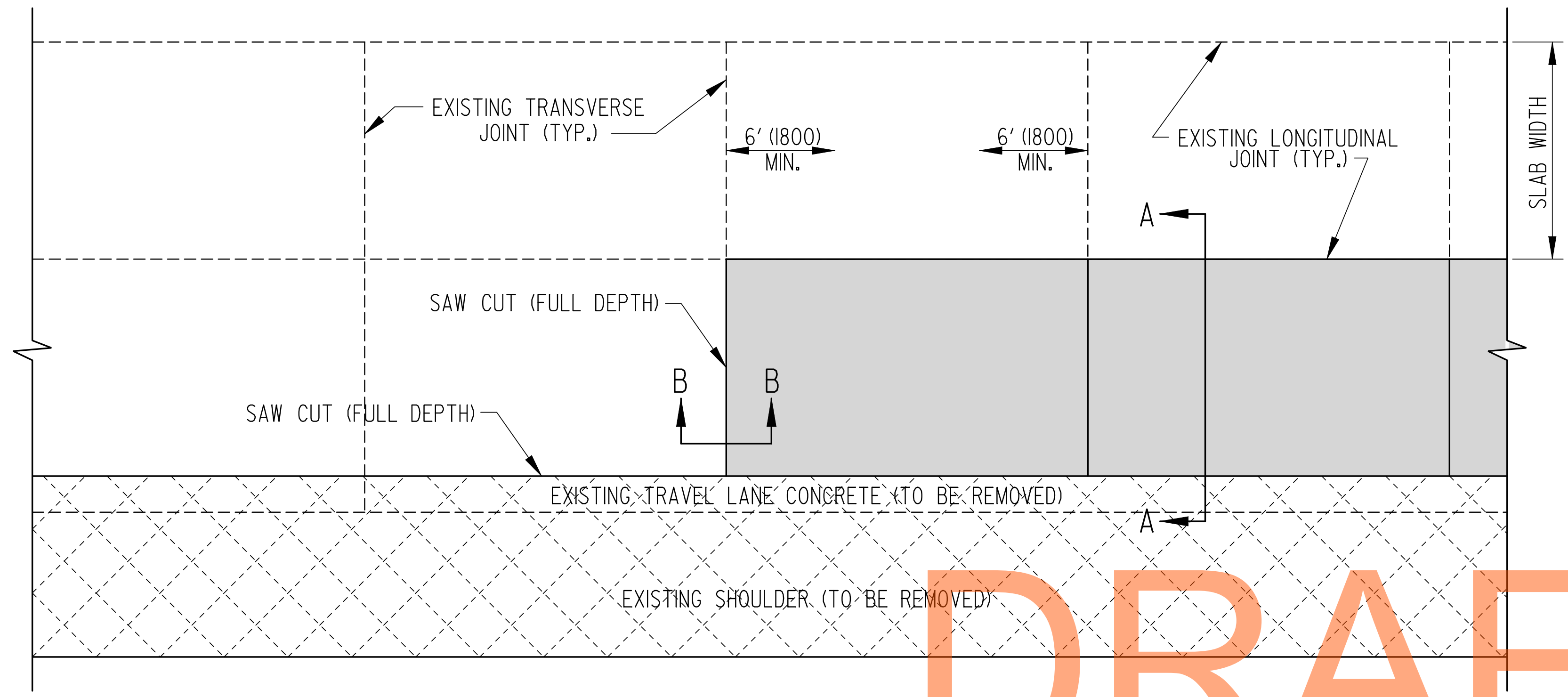

PLAN

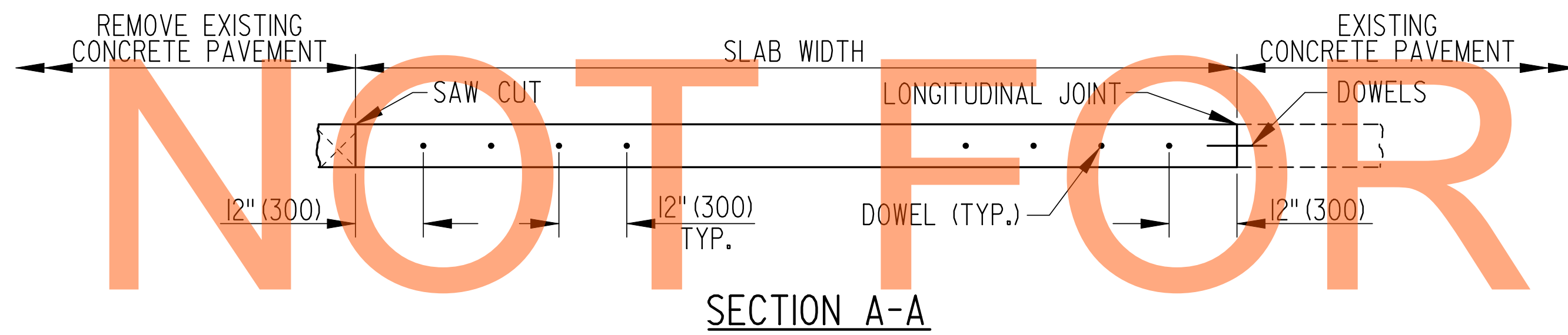

SECTION A-A

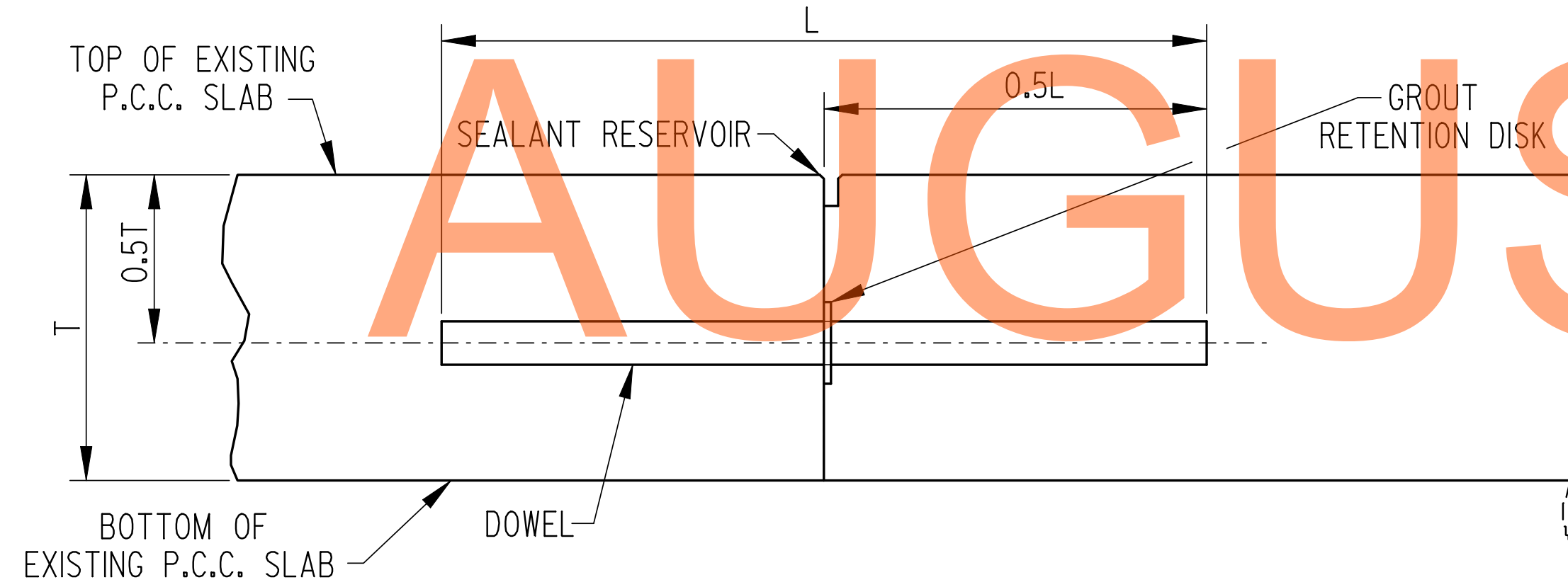

SECTION B-B

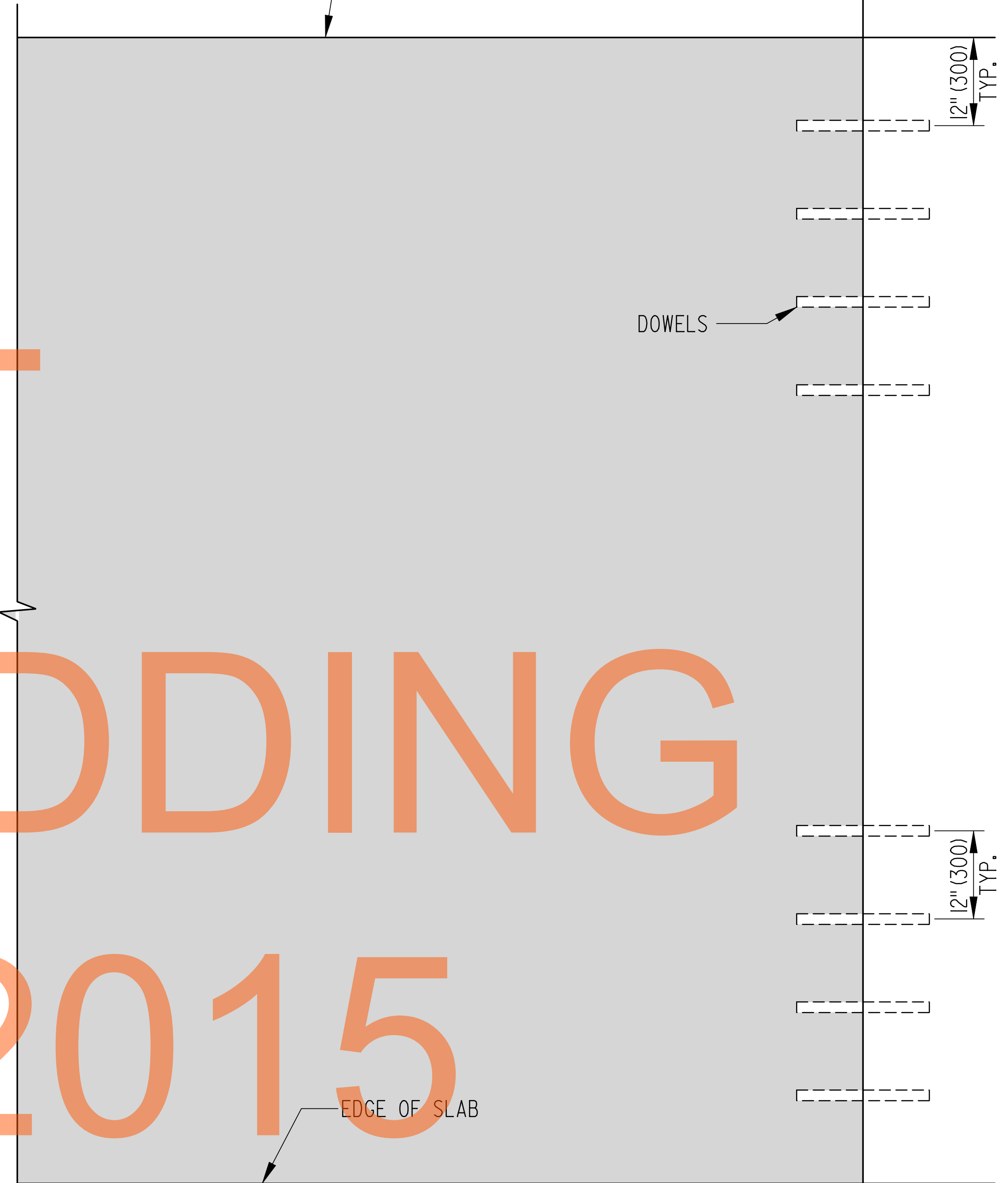

SLAB PLAN (WITH DOWEL AND TIE LOCATIONS)

NOTES:

1. PROPOSED LOCATIONS FOR TRANSVERSE JOINTS SHALL EXACTLY MATCH THE ALIGNMENT OF THE FINAL (EXISTING OR RELOCATED) TRANSVERSE JOINTS IN ALL IMMEDIATELY ADJACENT LANES. WHEN NOT ALIGNED WITH THE FINAL EXPECTED TRANSVERSE JOINT LOCATIONS IN THE IMMEDIATELY ADJACENT LANES, PROPOSED LOCATIONS FOR TRANSVERSE JOINTS SHALL BE OFFSET A MINIMUM OF 2' (600) FROM THE AFFORMENTIONED JOINTS.
2. THE LONGITUDINAL JOINT ALIGNMENT SHALL BE STRAIGHT AND CONTINUOUS.
3. SEE PAVEMENT JOINT LAYOUT SHEETS FOR DIMENSIONS AND LOCATIONS.

FULL DEPTH CONCRETE PAVEMENT
ADJACENT TO EXISTING PAVEMENT

ADDENDUMS / REVISIONS

NOT TO SCALE

US 301 &
SR 1 INTERCHANGE

CONTRACT	BRIDGE NO.
T200911302	
COUNTY	DESIGNED BY: BRT
NEW CASTLE	CHECKED BY: GBB

CONSTRUCTION DETAILS

DT-03
SHEET NO.
86
TOTAL SHTS.
491

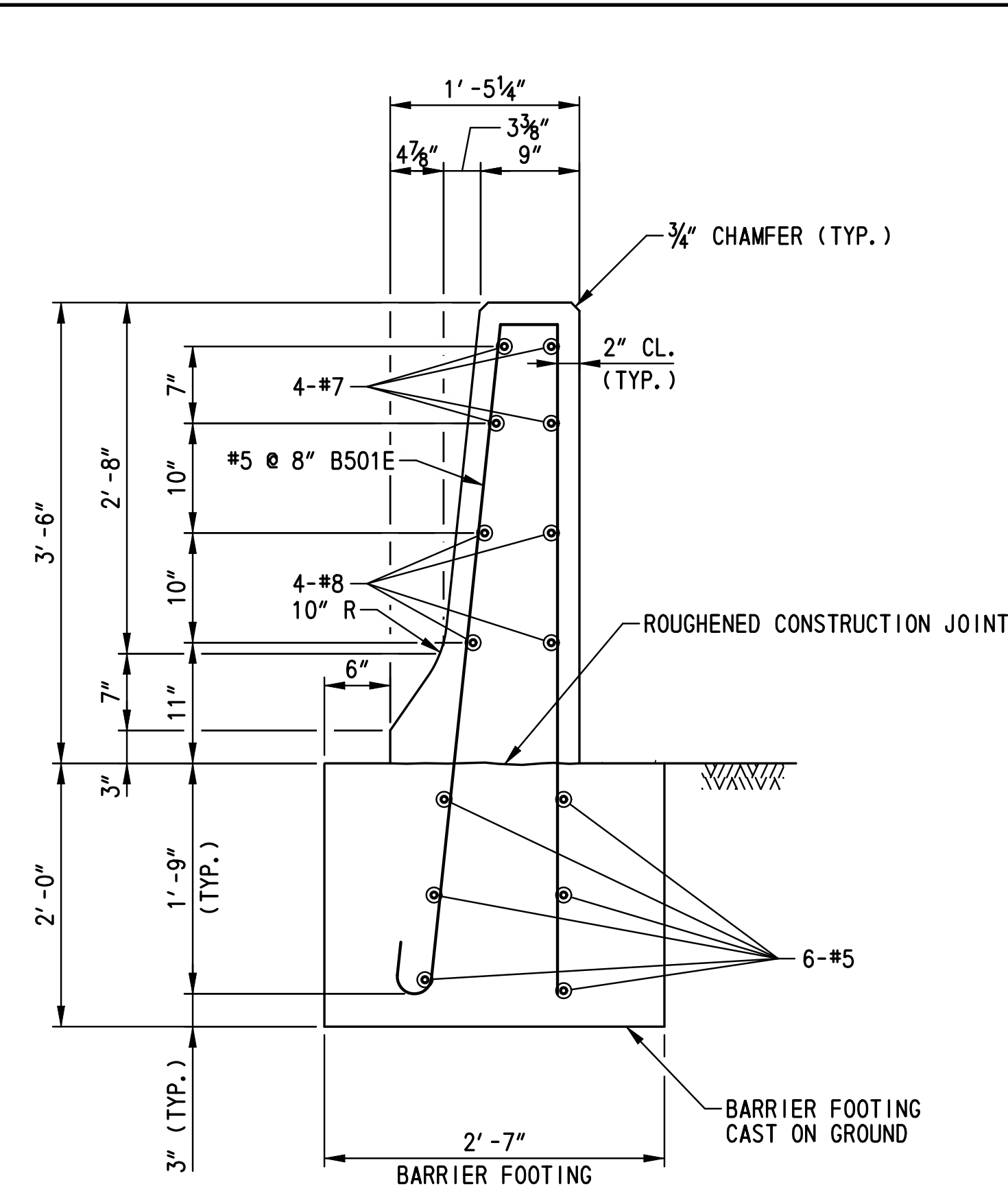

CONCRETE SINGLE FACE BARRIER TYPE 1
SCALE: 1"=1'-0"

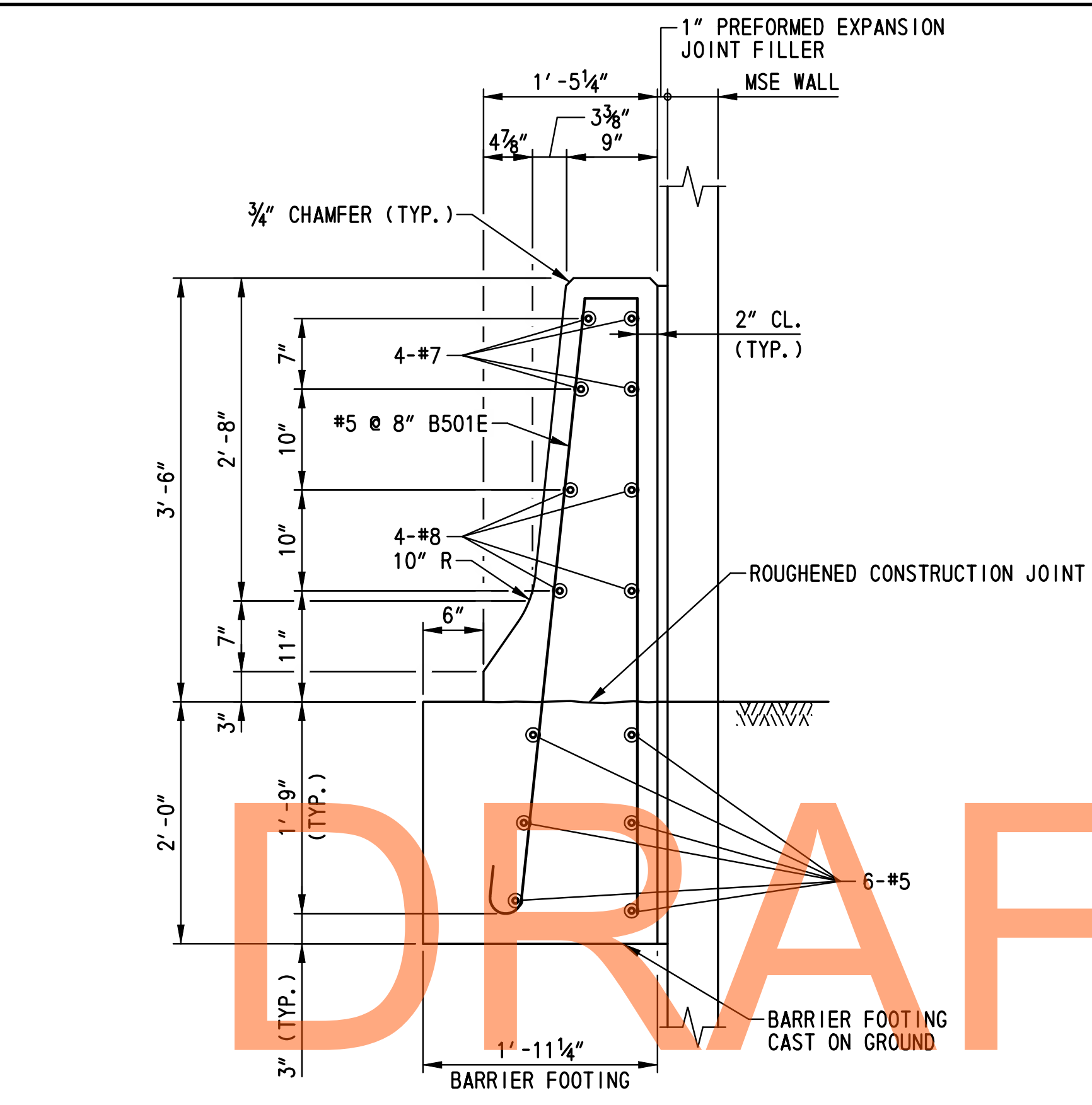

CONCRETE SINGLE FACE BARRIER TYPE 1 (MODIFIED)
SCALE: 1"=1'-0"

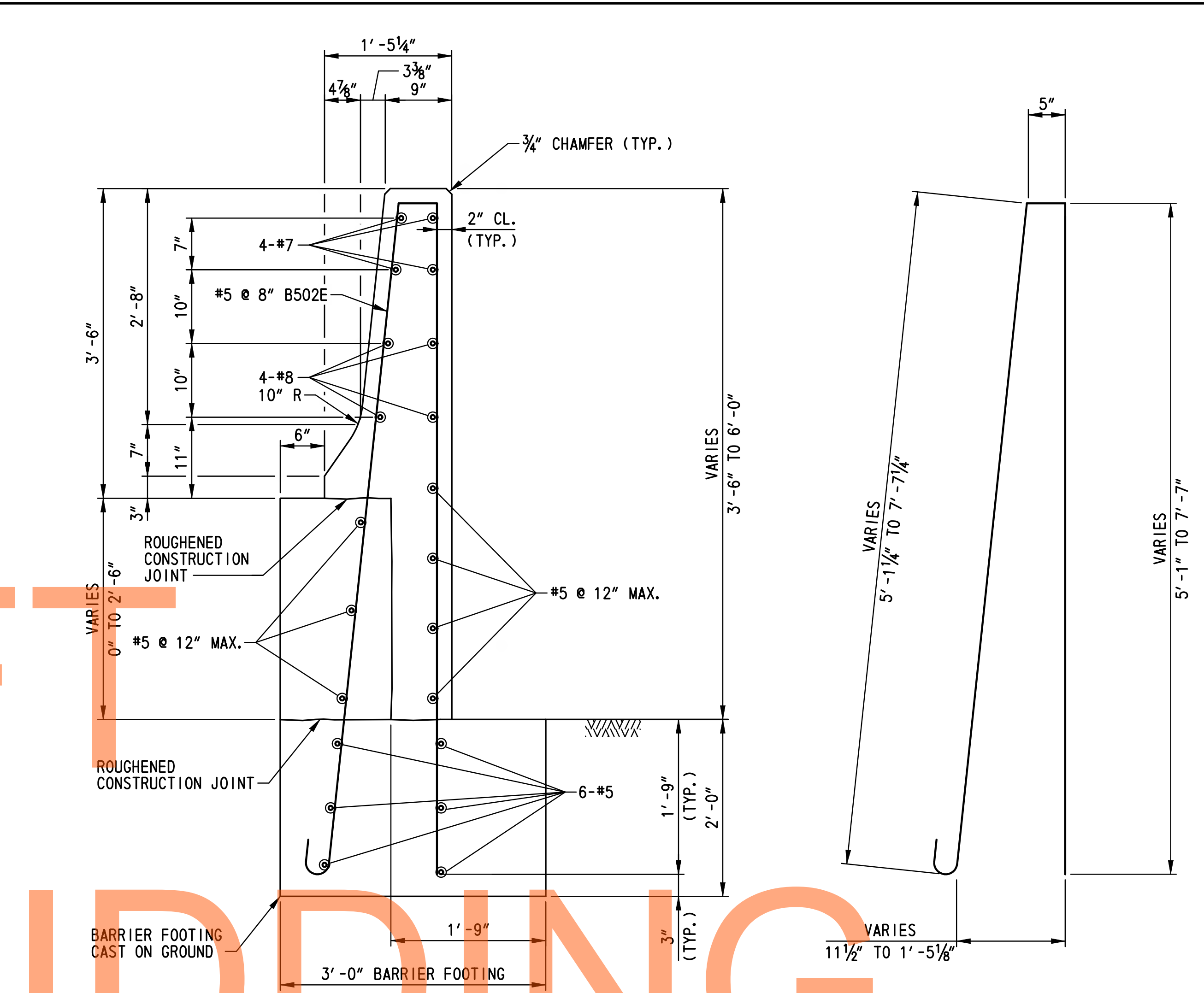

BIFURCATED CONCRETE MEDIAN BARRIER (MODIFIED)
SCALE: 1"=1'-0"

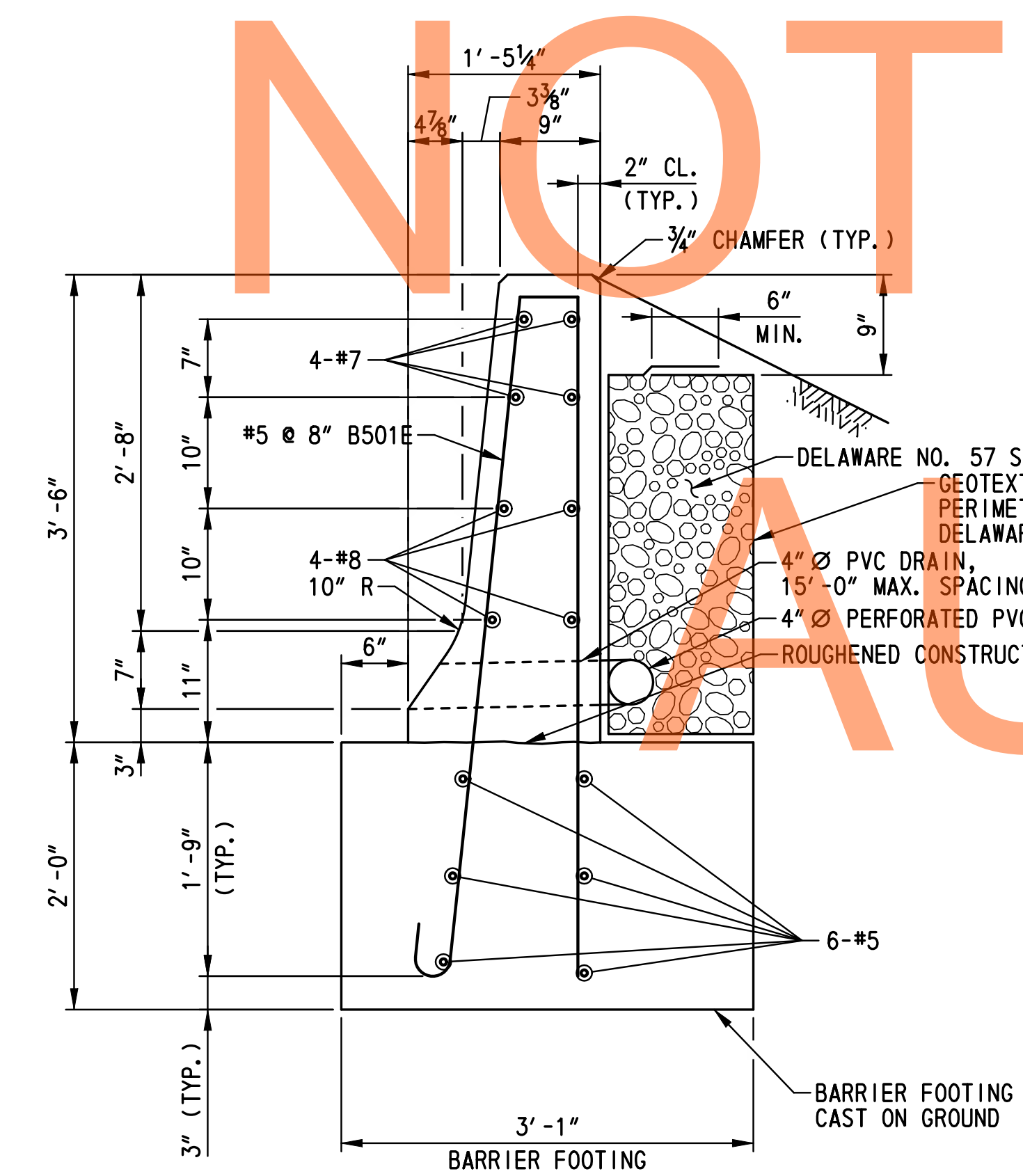

CONCRETE SINGLE FACE BARRIER TYPE 2
SCALE: 1"=1'-0"

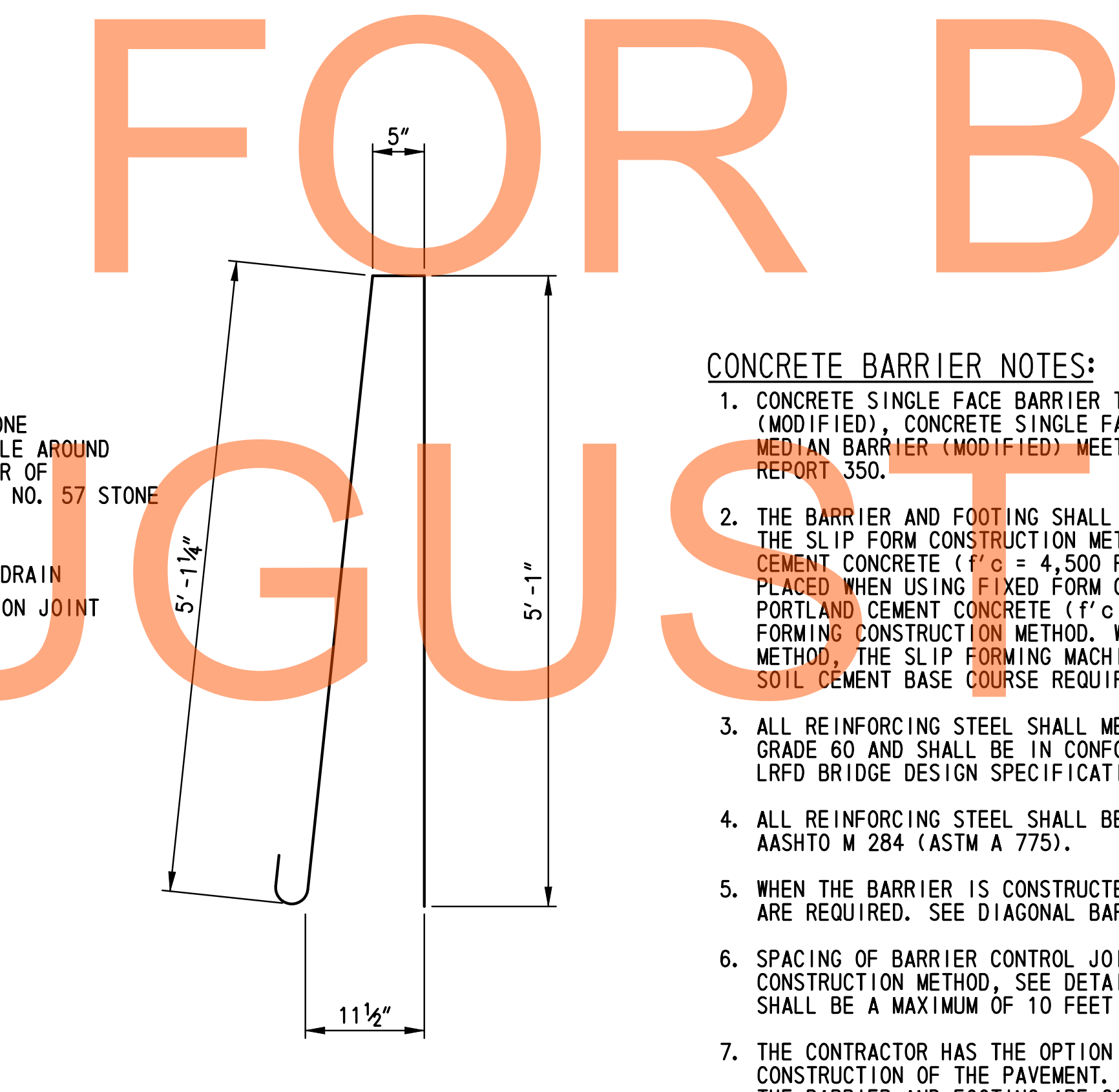

B501E
SCALE: 1"=1'-0"

CONCRETE BARRIER NOTES:

- CONCRETE SINGLE FACE BARRIER TYPE 1, CONCRETE SINGLE FACE BARRIER TYPE 1 (MODIFIED), CONCRETE SINGLE FACE BARRIER TYPE 2 AND BIFURCATED CONCRETE MEDIAN BARRIER (MODIFIED) MEET TL-4 LOADING CRITERIA AS SPECIFIED IN NCHRP REPORT 350.
- THE BARRIER AND FOOTING SHALL BE CAST SEPARATELY USING THE FIXED FORM OR THE SLIP FORM CONSTRUCTION METHOD. ALL CONCRETE SHALL BE CLASS A PORTLAND CEMENT CONCRETE ($f'c = 4,500$ PSI AT 28 DAYS) AND SHALL BE CONTINUOUSLY PLACED WHEN USING FIXED FORM CONSTRUCTION. ALL CONCRETE SHALL BE CLASS B PORTLAND CEMENT CONCRETE ($f'c = 3,000$ PSI AT 28 DAYS) WHEN USING THE SLIP FORMING CONSTRUCTION METHOD. WHEN USING THE SLIP FORMING CONSTRUCTION METHOD, THE SLIP FORMING MACHINE SHALL BE SUPPORTED OFF OF THE CONCRETE SOIL CEMENT BASE COURSE REQUIRED FOR THE ADJACENT ROADWAY.
- ALL REINFORCING STEEL SHALL MEET THE REQUIREMENTS OF AASHTO M 31 (ASTM A 615), GRADE 60 AND SHALL BE IN CONFORMANCE WITH THE CURRENT EDITION OF THE AASHTO LRFD BRIDGE DESIGN SPECIFICATIONS AND ALL BARS SHALL BE TIED TOGETHER.
- ALL REINFORCING STEEL SHALL BE PROTECTED WITH FUSION-BONDED EPOXY CONFORMING AASHTO M 284 (ASTM A 775).
- WHEN THE BARRIER IS CONSTRUCTED USING THE SLIP FORM METHOD, DIAGONAL NO. 5 BARS ARE REQUIRED. SEE DIAGONAL BAR DETAIL ON DWG. NO. DT-05.
- SPACING OF BARRIER CONTROL JOINTS SHALL BE A MAXIMUM OF 10 FEET REGARDLESS OF CONSTRUCTION METHOD, SEE DETAIL THIS SHEET. SPACING OF FOOTING CONTROL JOINTS SHALL BE A MAXIMUM OF 10 FEET AND ALIGN WITH THE CONTROL JOINTS IN THE BARRIER.
- THE CONTRACTOR HAS THE OPTION TO CONSTRUCT THE FOOTING AND BARRIER AFTER CONSTRUCTION OF THE PAVEMENT. THE FOOTING FORMS, IF USED, SHALL BE REMOVED IF THE BARRIER AND FOOTING ARE CONSTRUCTED BEFORE THE PAVEMENT.
- THE FOOTING REAR VERTICAL WALL SHALL BE FORMED OR THE CONCRETE PLACED AGAINST THE VERTICAL EARTH SIDE IF APPROVED BY THE ENGINEER. NO ADDITIONAL COMPENSATION FOR ADDITIONAL CONCRETE WILL BE PAID IF THE CONCRETE IS PLACED AGAINST THE EARTH.
- AT LOCATIONS WHERE CONCRETE SINGLE FACE BARRIER TYPE 2 IS REQUIRED ADJACENT TO CONCRETE SINGLE FACE BARRIER TYPE 1 (MODIFIED), THE BARRIER FOOTING WIDTH OF THE CONCRETE SINGLE FACE BARRIER TYPE 2 SHALL VARY. THE FOOTING WIDTH SHALL VARY FROM 1'-11 1/4" ADJACENT TO THE CONCRETE SINGLE FACE BARRIER TYPE 1 (MODIFIED) TO 3'-1" WHEN THERE IS SUFFICIENT ROOM IN FRONT OF THE MSE WALL.
- THE CONTRACTOR SHALL ATTACH THE YELLOW AND/OR WHITE REFLECTORS TO THE BARRIERS AS SHOWN IN THE DETAIL ON DWG. NO. DT-05. PAYMENT FOR THE REFLECTORS SHALL BE IN ACCORDANCE WITH ITEM NOS. 720544 AND 720545 AS APPROPRIATE.
- PRIOR TO PLACING BARRIER CONCRETE ADJACENT TO EXISTING CONCRETE PAVEMENT, OR PRIOR TO PLACING CONCRETE PAVEMENT ADJACENT TO EXISTING BARRIER CONCRETE, AN APPROVED BOND BREAKER SHALL BE APPLIED TO THE EXISTING CONCRETE VERTICAL FACE. THIS LONGITUDINAL JOINT AT THE INTERFACE BETWEEN THE CONCRETE PAVEMENT AND THE BARRIER CONCRETE SHALL NOT BE SEALED. VERTICAL CRACKS IN THE EXISTING CONCRETE FACE SHALL BE COVERED OR SEALED AS APPROVED BY THE ENGINEER TO PREVENT INTRUSION OF THE NEW CONCRETE INTO THE EXISTING CONCRETE. ALL WORK SHALL BE INCIDENTAL TO THE APPROPRIATE BARRIER ITEM.
- COST OF THE CONCRETE SINGLE FACE BARRIER TYPE 1 (MODIFIED) SHALL BE PAID FOR UNDER CONCRETE SINGLE FACE BARRIER TYPE 1 (720626). COST OF THE CONCRETE SINGLE FACE BARRIER TYPE 1 AND TYPE 1 (MODIFIED) CONCRETE FOOTING, REINFORCING STEEL, PREFORMED EXPANSION JOINT FILLER AND EXCAVATION SHALL BE INCIDENTAL TO THE CONTRACT UNIT PRICE PER LINEAR FOOT FOR CONCRETE SINGLE FACE BARRIER TYPE 1 (720627).
- COST OF THE CONCRETE SINGLE FACE BARRIER TYPE 2 CONCRETE FOOTING, REINFORCING STEEL, PVC DRAIN PIPE, PERFORATED PVC DRAIN PIPE, GEOTEXTILE, DELAWARE NO. 57 STONE AND EXCAVATION SHALL BE INCIDENTAL TO THE CONTRACT UNIT PRICE PER LINEAR FOOT FOR CONCRETE SINGLE FACE BARRIER TYPE 2 (720627).
- COST OF THE BIFURCATED CONCRETE MEDIAN BARRIER (MODIFIED) SHALL BE PAID FOR UNDER BIFURCATED CONCRETE MEDIAN BARRIER (720629). COST OF THE BIFURCATED CONCRETE MEDIAN BARRIER FOOTING, REINFORCING STEEL AND EXCAVATION SHALL BE INCIDENTAL TO THE CONTRACT UNIT PRICE PER LINEAR FOOT FOR BIFURCATED CONCRETE MEDIAN BARRIER (720629).

P:\3653-000\sm\mfg\ct_lb\ccad\DT004\B30_L_IB.dgn
 2/27/2015 12:15:11 PM

ADDENDUMS / REVISIONS	

SCALE: AS SHOWN

US 301 & SR 1 INTERCHANGE

CONTRACT	BRIDGE NO.
T200911302	
COUNTY	DESIGNED BY: K.M.K.
NEW CASTLE	CHECKED BY: B.K.B.

CONSTRUCTION DETAILS	SHEET NO.
	87
	TOTAL SHTS.
	491

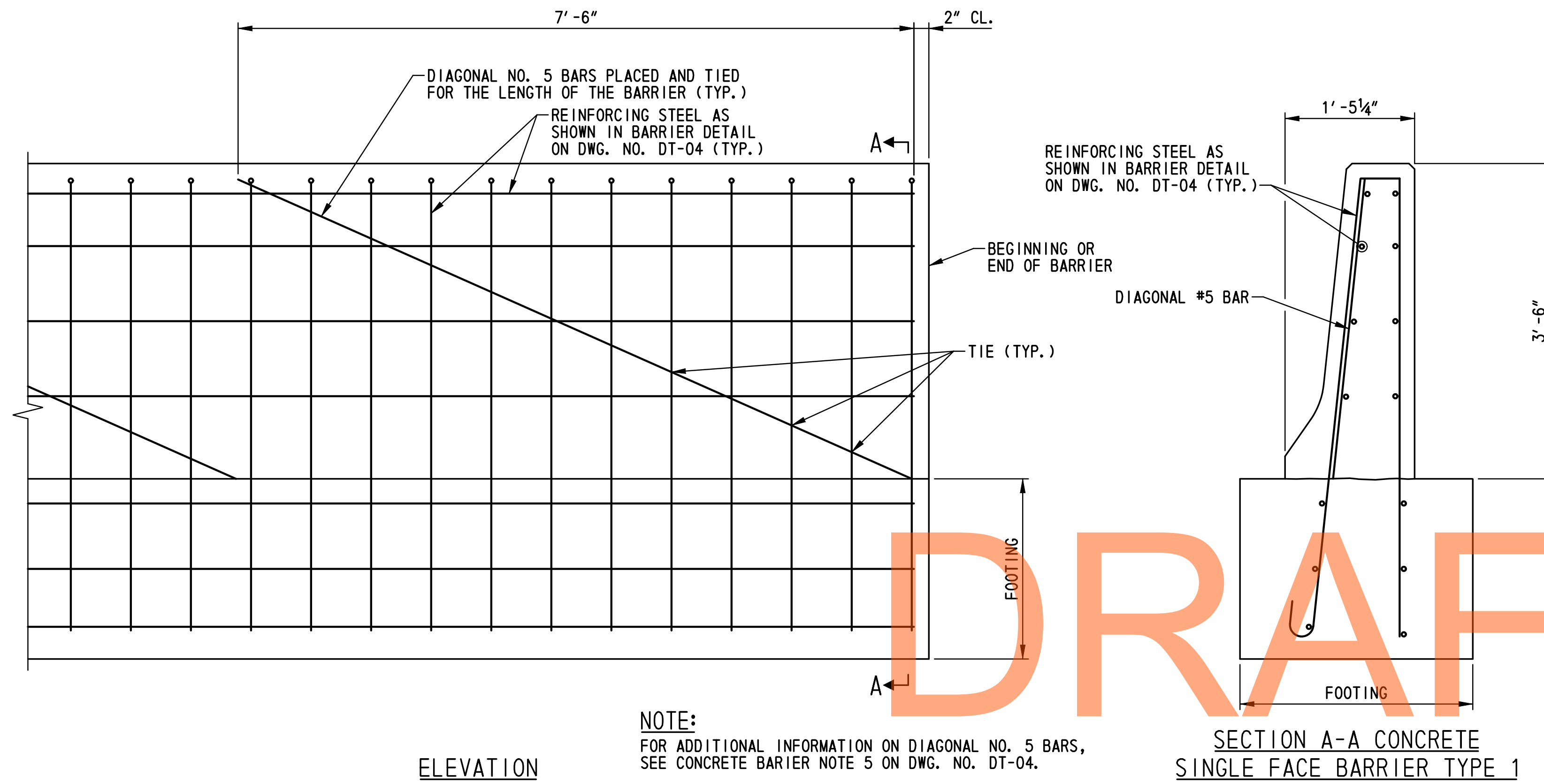

ELEVATION

SECTION A-A CONCRETE SINGLE FACE BARRIER TYPE 1

NOTE:
FOR ADDITIONAL INFORMATION ON DIAGONAL NO. 5 BARS, SEE CONCRETE BARRIER NOTE 5 ON DWG. NO. DT-04.

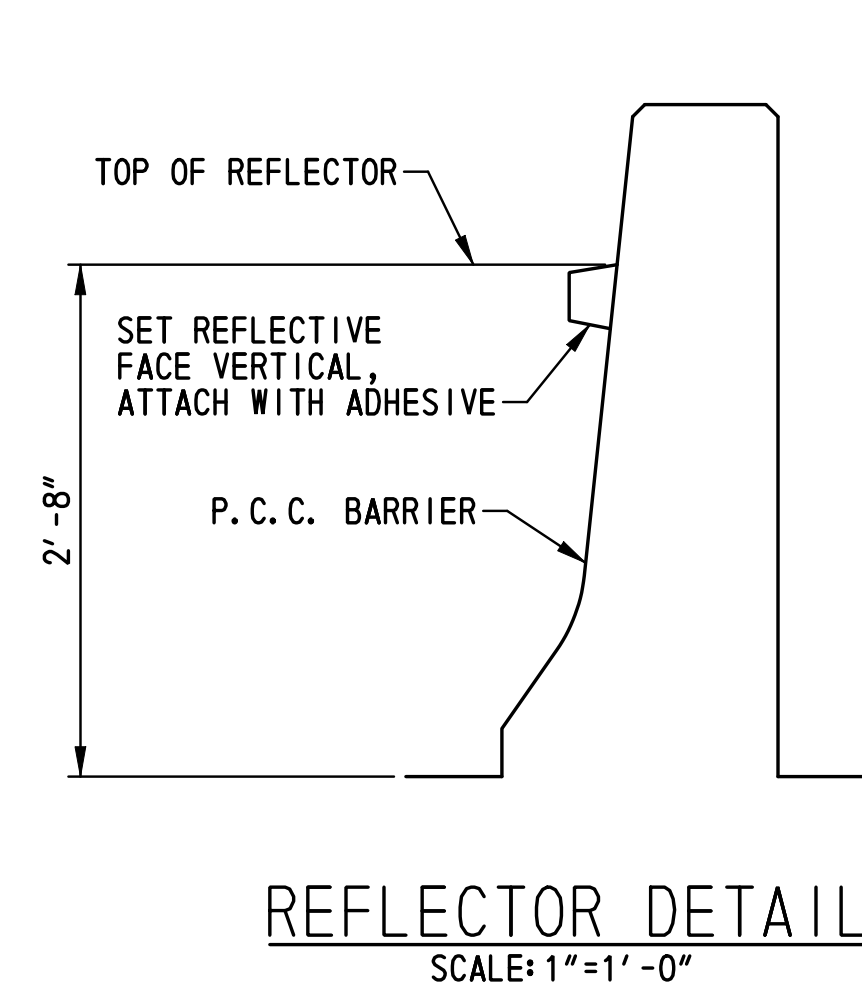

REFLECTOR DETAIL
SCALE: 1"=1'-0"

- REFLECTOR DETAIL NOTES:
- COLOR OF REFLECTOR ON TRAFFIC SIDE SHALL MATCH ADJACENT LANE LINE COLOR. BACK SIDE OF ALL REFLECTORS SHALL BE RED.
 - THE SPACING OF REFLECTORS ON PERMANENT P.C.C. BARRIER SHALL BE COORDINATED WITH THE DELINEATORS AT THE APPROACHES TO THE BARRIER SUCH THAT THE SPACING OF DELINEATORS/REFLECTORS DOES NOT EXCEED 100 FT.
 - ALL COST SHALL BE INCLUDED IN ITEM 720544 - REFLECTORS, WHITE, CONCRETE AND 720545 - REFLECTORS, YELLOW, CONCRETE.

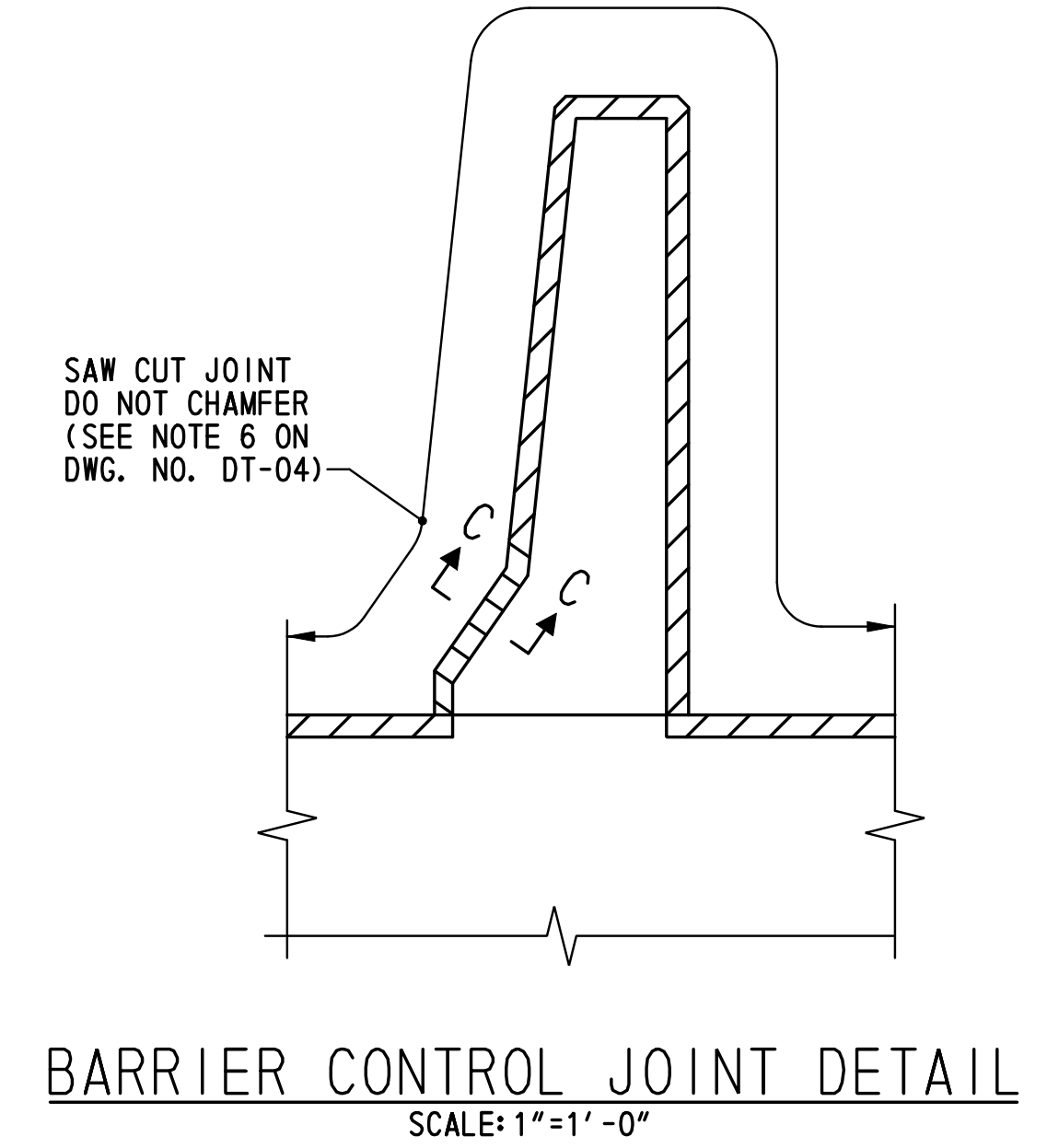

BARRIER CONTROL JOINT DETAIL
SCALE: 1"=1'-0"

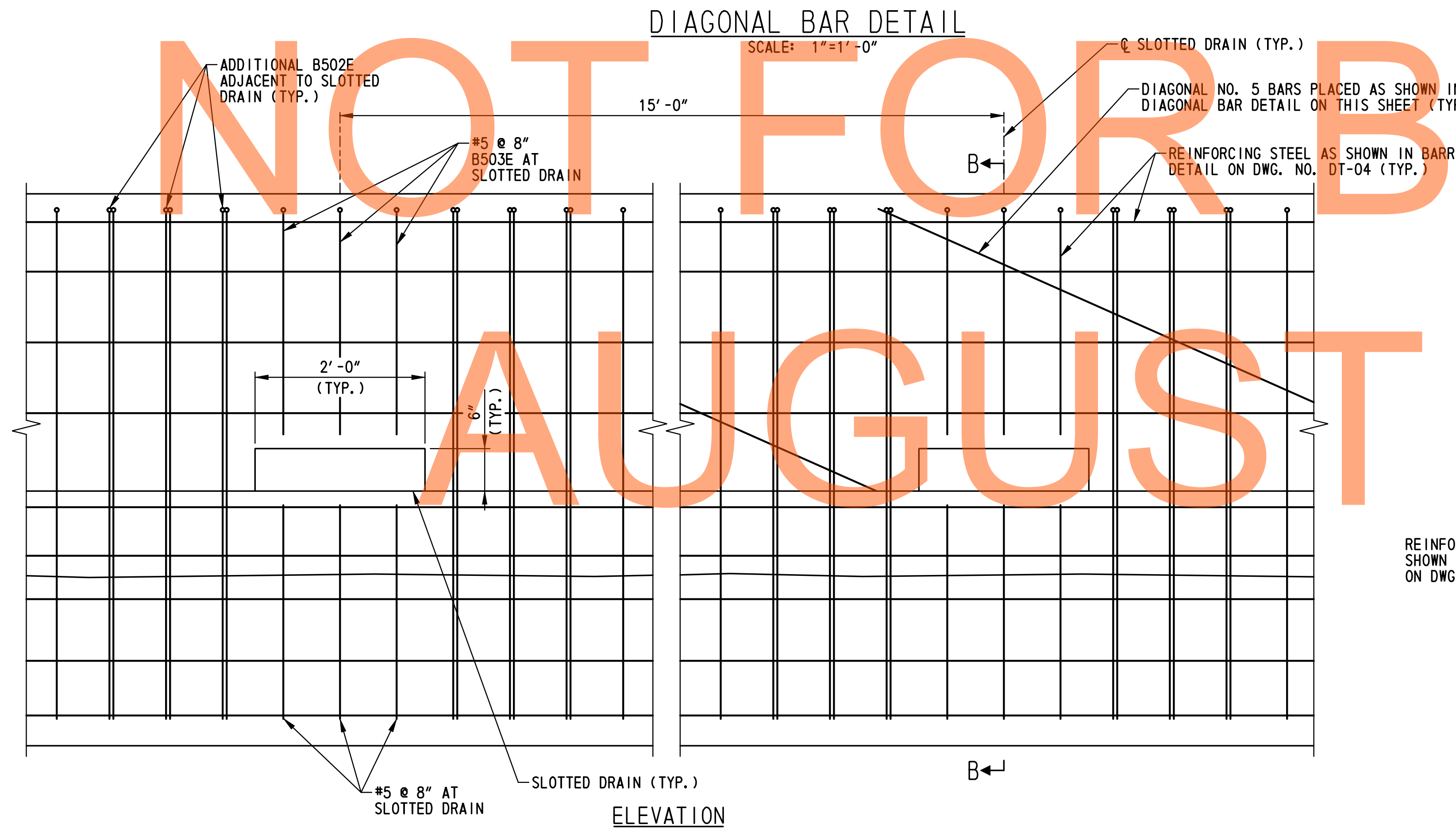

DIAGONAL BAR DETAIL
SCALE: 1"=1'-0"

SLOTTED BARRIER DETAIL
SCALE: 1"=1'-0"

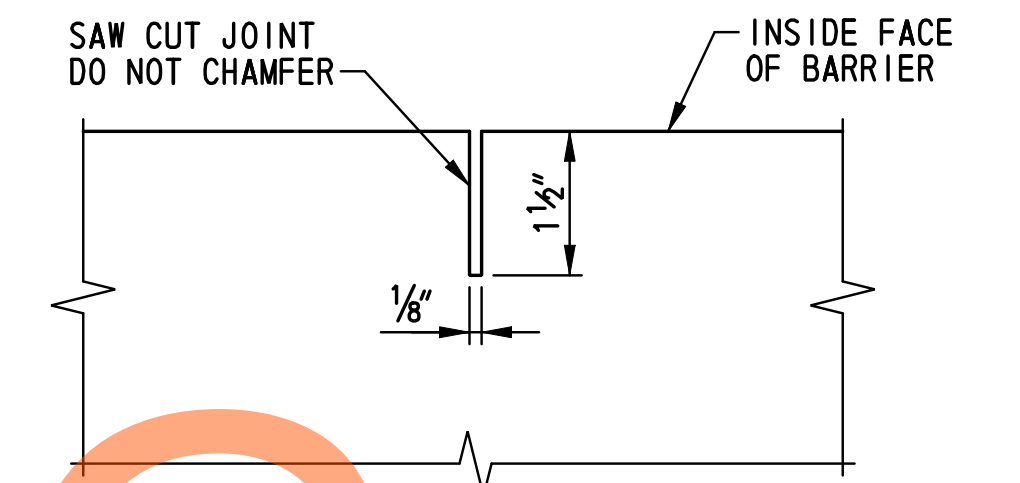

SECTION C-C
SCALE: 6"=1'-0"

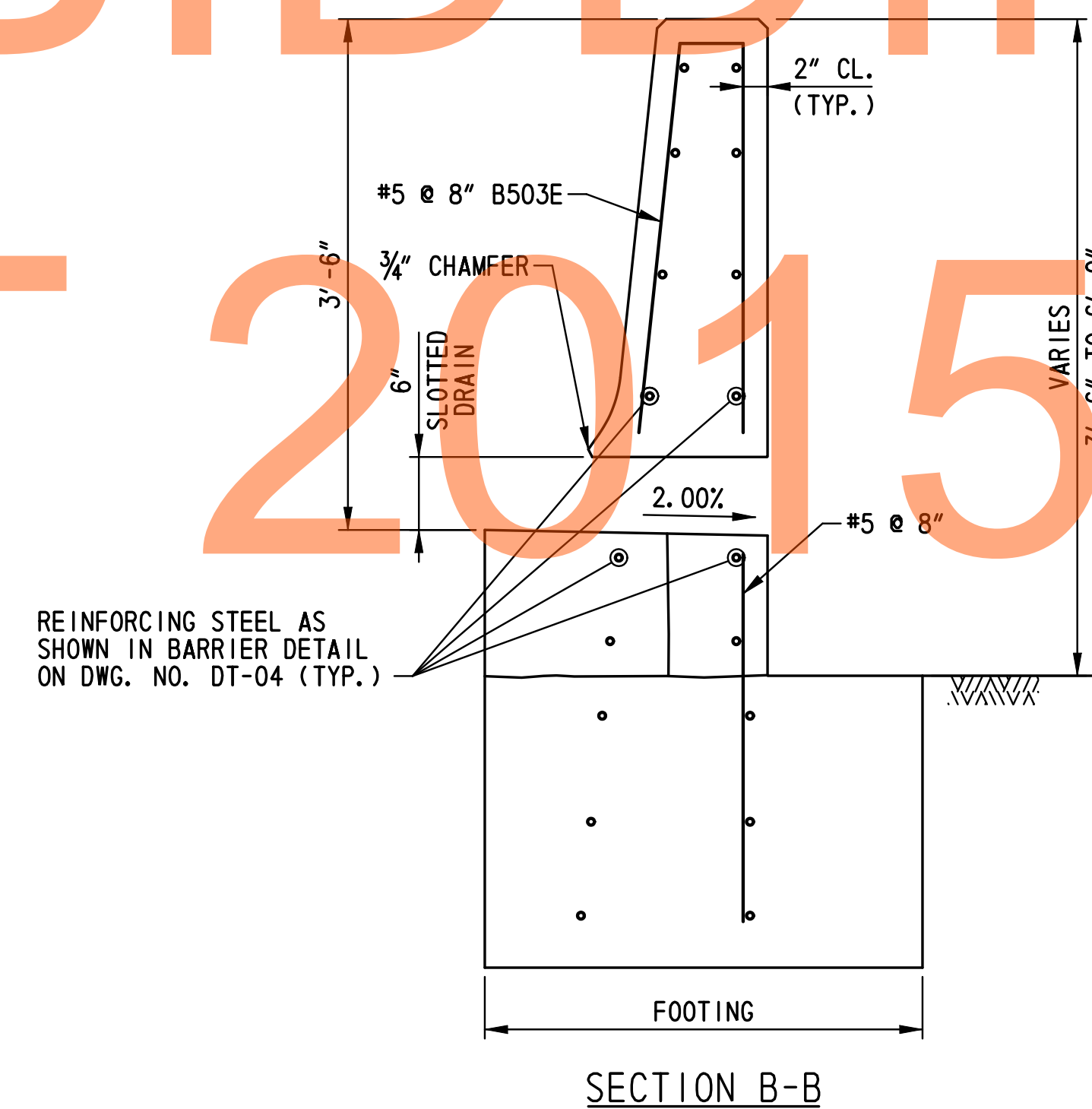

SECTION B-B

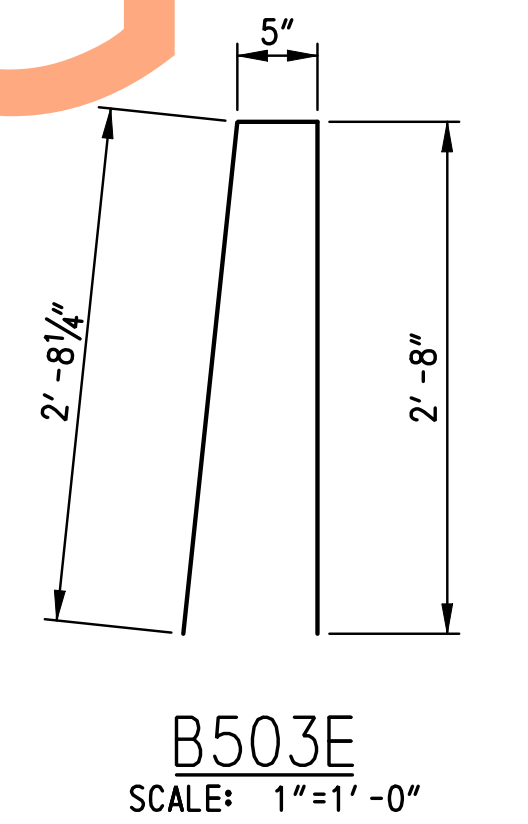

B503E
SCALE: 1"=1'-0"

- NOTES:
- DIAGONAL BAR DETAIL AND BARRIER CONTROL JOINT DETAIL SHOWN FOR CONCRETE SINGLE FACE BARRIERS. DIAGONAL BAR DETAIL FOR BIFURCATED CONCRETE MEDIAN BARRIER (MODIFIED) SIMILAR.
 - SLOTTED BARRIER DETAIL SHOWN FOR BIFURCATED CONCRETE MEDIAN BARRIER. SLOTTED BARRIER DETAIL FOR CONCRETE SINGLE FACE BARRIERS SIMILAR.
 - SLOTTED BARRIER SHALL BE FORMED BY PLACING BLOCKS IN THE BARRIER WALL PRIOR TO CONCRETE PLACEMNT. CONCRETE SHALL CURE SUFFICIENTLY TO RETAIN FROM BEFORE BLOCKS ARE REMOVED.
 - ALL WORK ASSOCIATED WITH SLOTTED DRAINS SHALL BE INCIDENTAL TO THE PERTINENT CONCRETE BARRIER PAYMENT ITEM.
 - FOR CONCRETE BARRIER NOTES, SEE DWG. NO. DT-04.

ADDENDUMS / REVISIONS

SCALE: AS SHOWN

US 301 &
SR 1 INTERCHANGE

CONTRACT	BRIDGE NO.
T200911302	
COUNTY	DESIGNED BY: K.M.K
NEW CASTLE	CHECKED BY: B.K.B.

CONSTRUCTION DETAILS

DT-05
SHEET NO.
88
TOTAL SHTS.
491

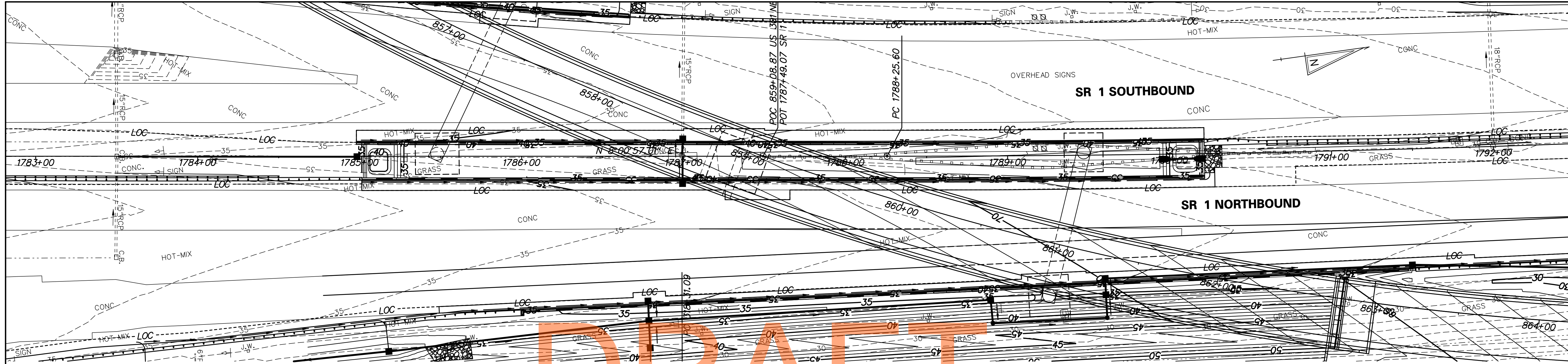

DRAFT

NOT FOR BIDDING

AUGUST 2015

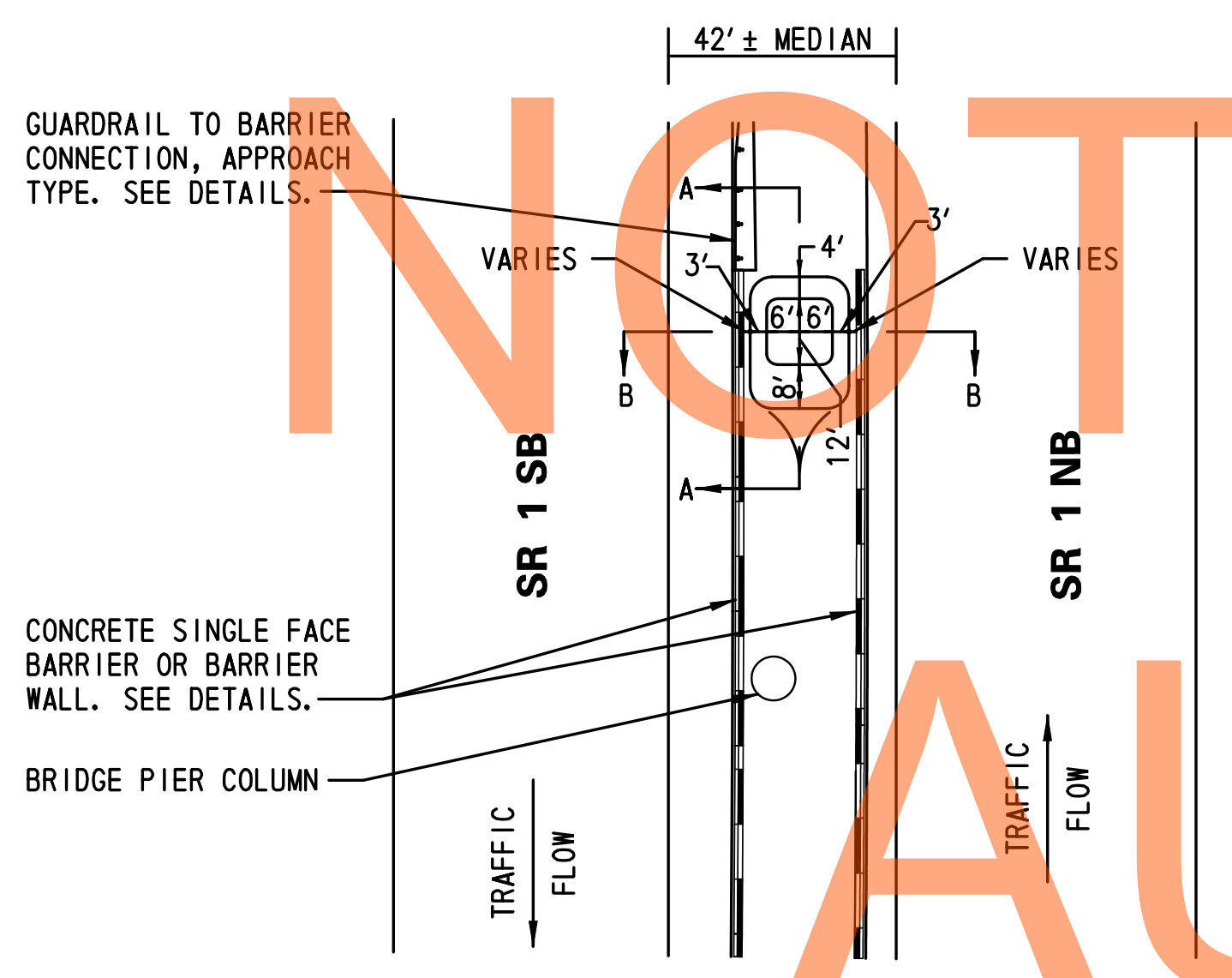

NOTES:
1. SEE PLAN SHEETS FOR LENGTH AND APPLICATION OF GUARDRAIL, CONCRETE SINGLE FACE BARRIER AND BARRIER WALLS.

BRIDGE PIER PROTECTION SYSTEM
MAINLINE BRIDGE PIER AND
MEDIAN OPENING PROTECTION PLAN
NOT TO SCALE

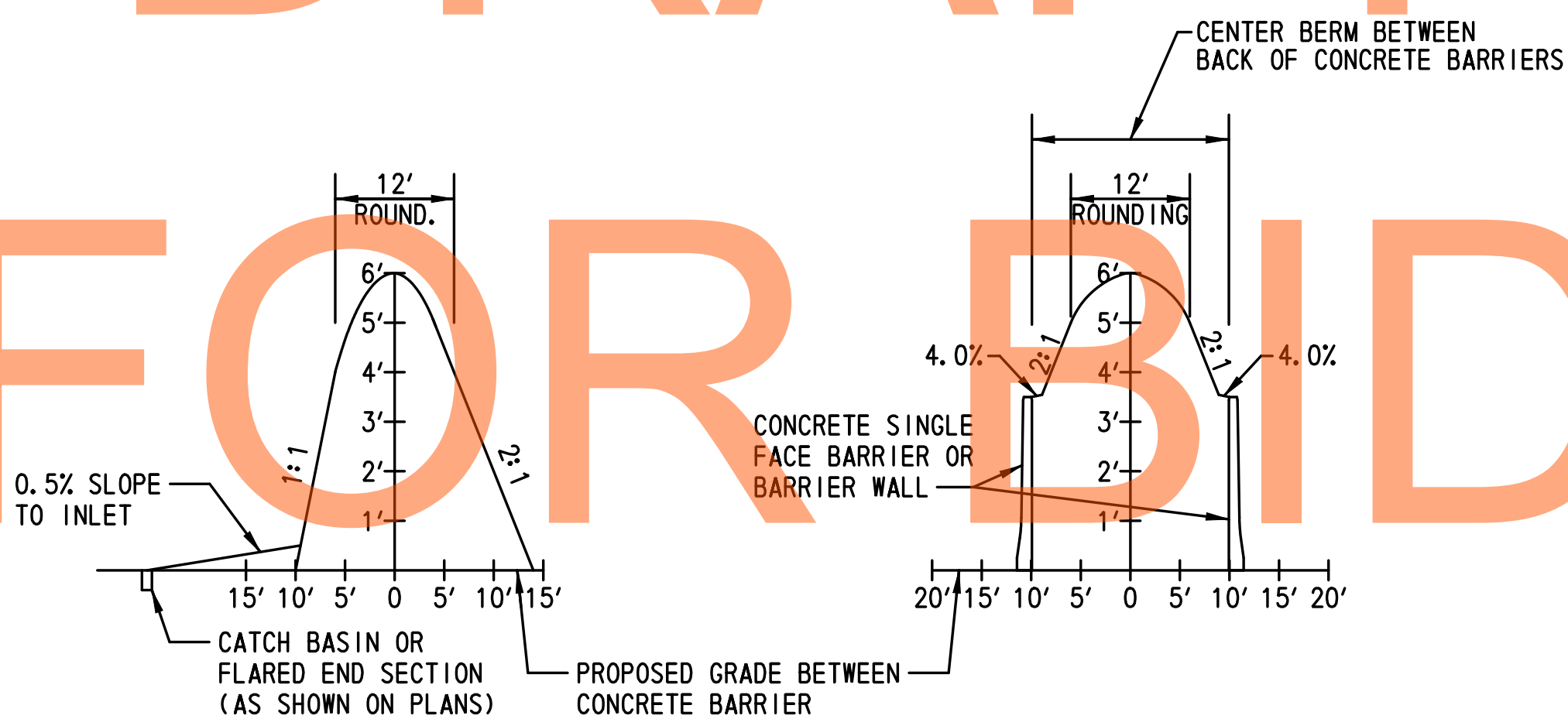

SECTION A-A NOT TO SCALE
SECTION B-B NOT TO SCALE

NOTES:
1. DISTANCE BETWEEN THE BACK OF BARRIER AND THE TOE OF SLOPE FOR THE EARTH MOUND SHALL NOT EXCEED FOUR (4) FEET.
2. SEE PLAN SHEETS FOR THE LOCATIONS OF EARTH MOUNDS AT BRIDGE PIER APPROACHES ALONG SR 1.
3. EARTH MOUND SHALL BE CONSTRUCTED OF MATERIALS MEETING THE REQUIREMENTS OF BORROW, TYPE F AND COMPACTED IN ACCORDANCE WITH SECTION 202.
4. STABILIZE MOUND SURFACE WITH TOPSOIL, SEED AND MULCH PER ROADWAY TYPICAL SECTIONS.

EARTH MOUND DETAILS AT
BRIDGE PIER APPROACHES
NOT TO SCALE

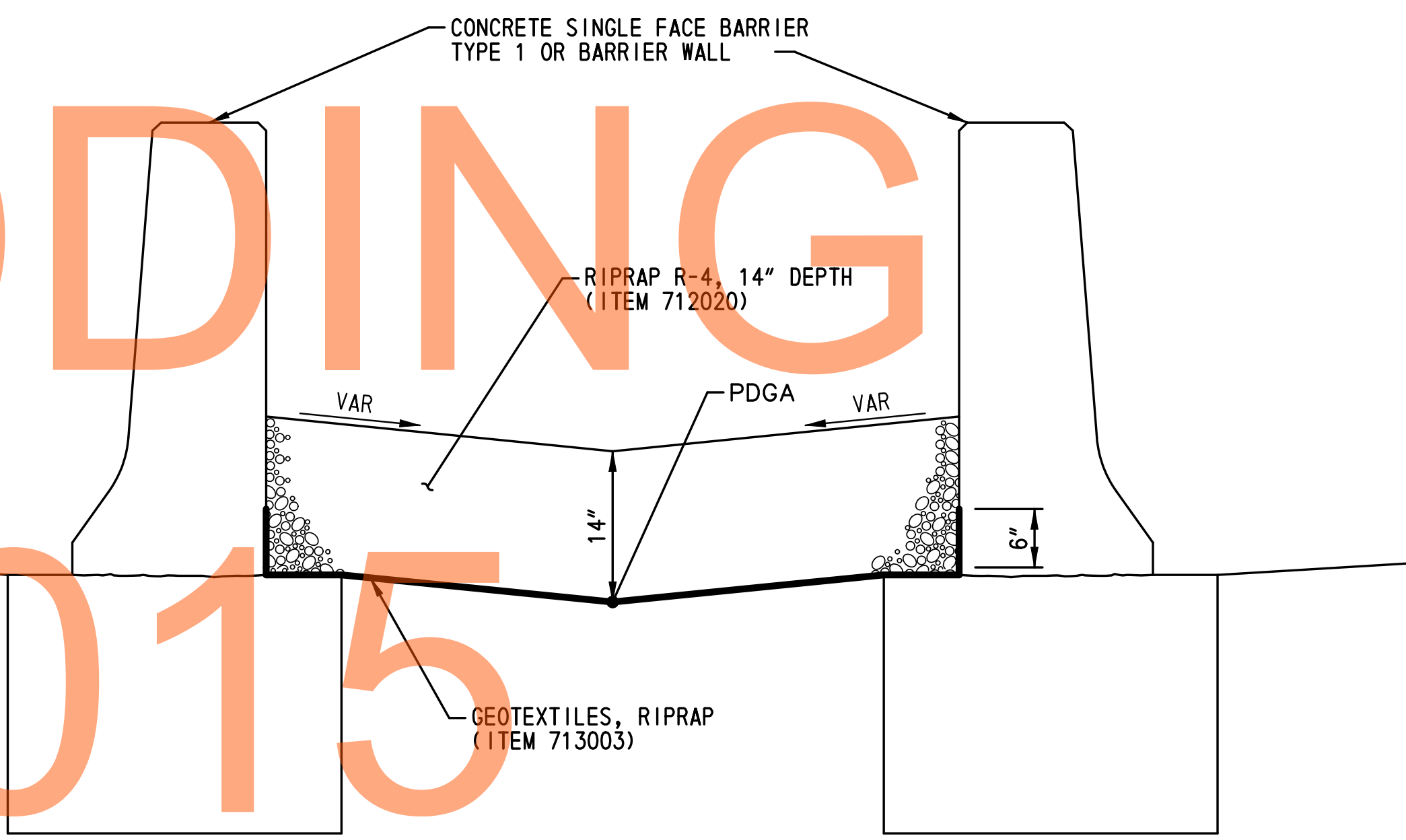

NOTES:
1. SEE SHEETS TS-13, GG-03, AND GG-10 FOR APPLICATION.

RIPRAP R-4 MEDIAN TREATMENT
NOT TO SCALE

MEDIAN PIER PROTECTION
BRIDGE BR1-3



ADDENDUMS / REVISIONS

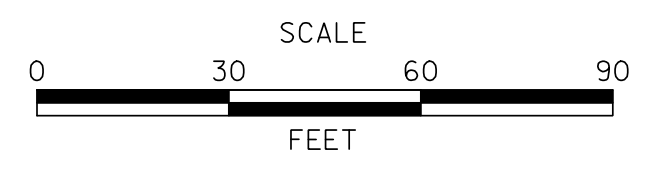

US 301 &
SR 1 INTERCHANGE

CONTRACT T200911302	BRIDGE NO.
COUNTY NEW CASTLE	DESIGNED BY: KAH
	CHECKED BY: BRT

CONSTRUCTION DETAILS

DT-06
SHEET NO. 89
TOTAL SHTS. 491

P:\31653-000\31653.dwg, 12/15/15, 2:28:25 PM

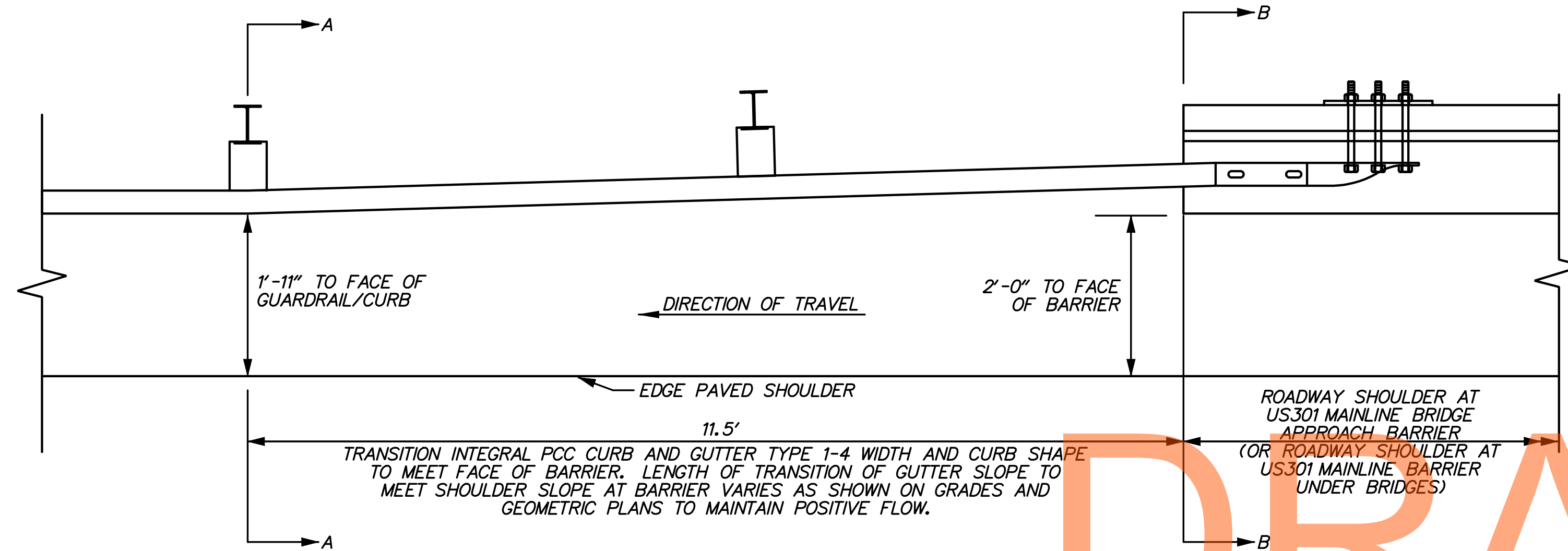
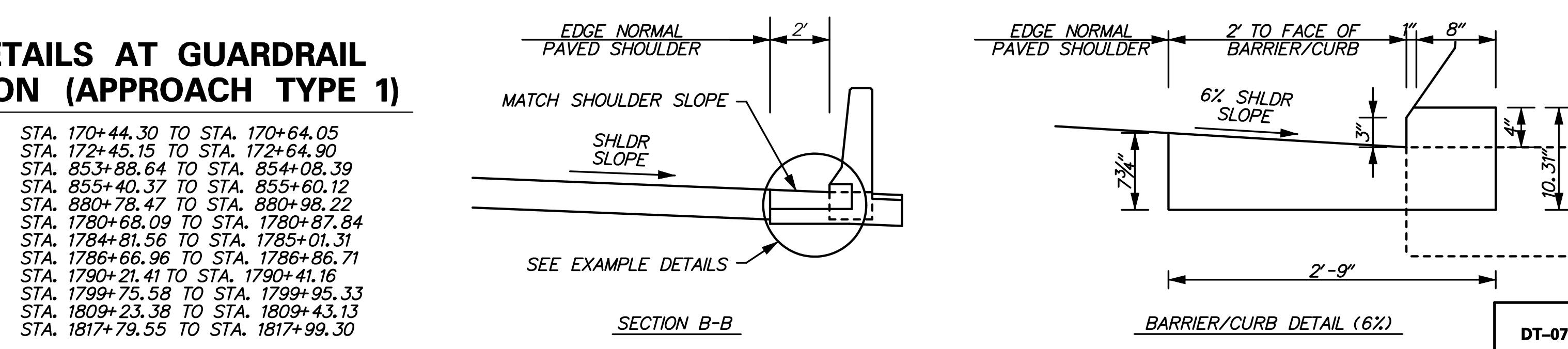
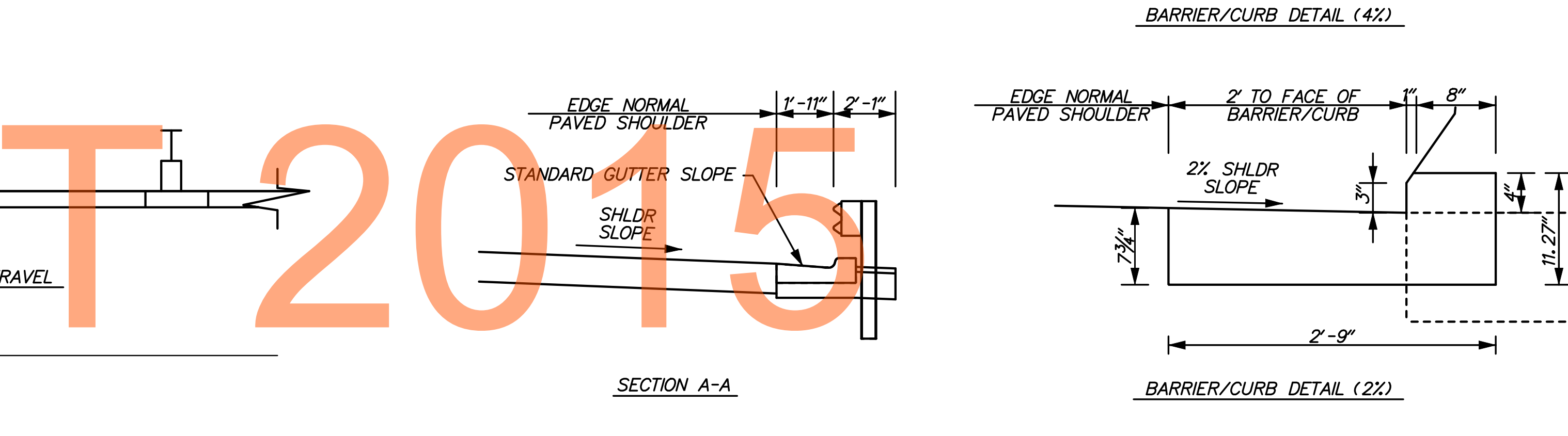
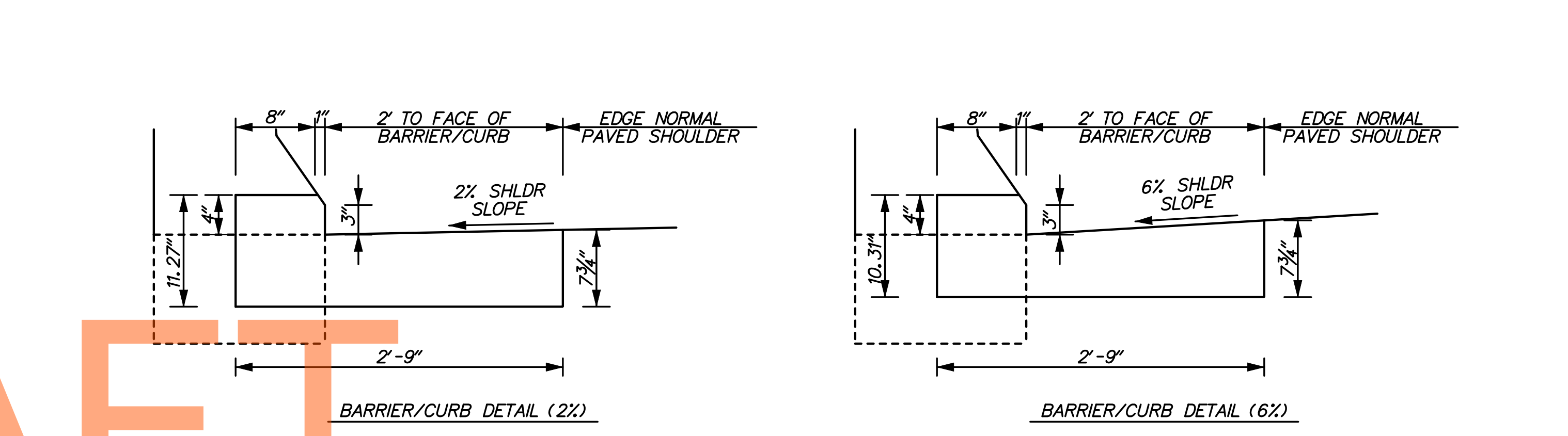
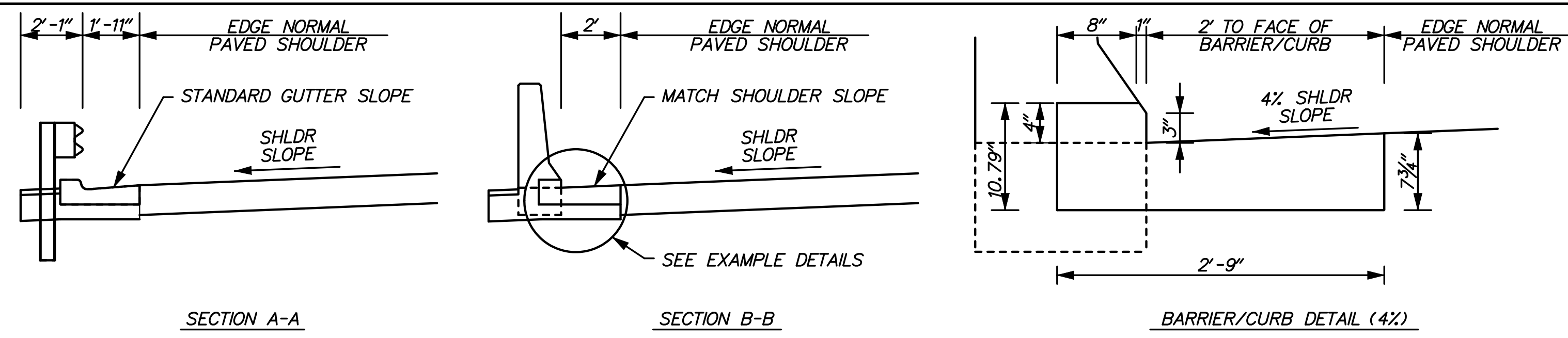

CURB TRANSITION DETAILS AT GUARDRAIL TO BARRIER CONNECTION (EXIT TYPE)

- US 13 SOUTHBOUND OUTSIDE SHOULDER: STA. 171+70.29 TO STA. 171+81.79
- US 301 NORTHBOUND LEFT SHOULDER: STA. 872+00.00 TO STA. 872+11.50
- US 301 NORTHBOUND RIGHT SHOULDER: STA. 882+97.23 TO STA. 883+16.98
- US 301 NORTHBOUND LEFT SHOULDER: STA. 882+97.72 TO STA. 883+09.22
- SR 1 SOUTHBOUND OUTSIDE SHOULDER: STA. 1784+17.31 TO STA. 1784+28.81
- SR 1 NORTHBOUND OUTSIDE SHOULDER: STA. 1785+89.80 TO STA. 1786+01.30
- SR 1 NORTHBOUND OUTSIDE SHOULDER: STA. 1791+50.00 TO STA. 1791+61.50
- SR 1 SOUTHBOUND OUTSIDE SHOULDER: STA. 1807+97.76 TO STA. 1808+09.26
- SR 1 SOUTHBOUND INSIDE SHOULDER: STA. 1809+28.56 TO STA. 1809+40.06
- SR 1 NORTHBOUND OUTSIDE SHOULDER: STA. 1811+02.88 TO STA. 1811+14.38

- NOTES:**
- PLACE PREFORMED EXPANSION JOINT MATERIAL BETWEEN END OF CURB AND BARRIER PER SECTION 701.01.
 - TRANSITION LIMITS TO BE MEASURED FOR PAYMENT UNDER ITEM 701016 WITH ALL COSTS FOR TRANSITION INCLUDED IN ITEM 701016.

DRAFT

NOT FOR BIDDING

AUGUST 2015

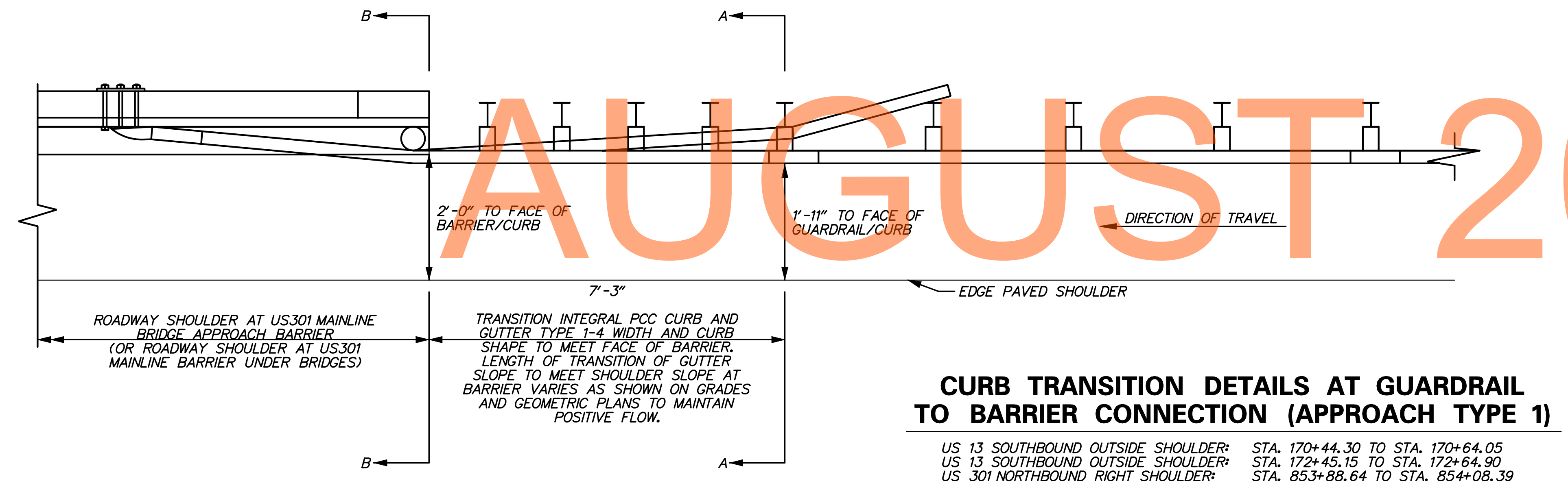

CURB TRANSITION DETAILS AT GUARDRAIL TO BARRIER CONNECTION (APPROACH TYPE 1)

- US 13 SOUTHBOUND OUTSIDE SHOULDER: STA. 170+44.30 TO STA. 170+64.05
- US 13 SOUTHBOUND OUTSIDE SHOULDER: STA. 172+45.15 TO STA. 172+64.90
- US 301 NORTHBOUND RIGHT SHOULDER: STA. 853+88.64 TO STA. 854+08.39
- US 301 NORTHBOUND LEFT SHOULDER: STA. 855+40.37 TO STA. 855+60.12
- US 301 NORTHBOUND LEFT SHOULDER: STA. 880+78.47 TO STA. 880+98.22
- SR 1 NORTHBOUND OUTSIDE SHOULDER: STA. 1780+68.09 TO STA. 1780+87.84
- SR 1 NORTHBOUND INSIDE SHOULDER: STA. 1784+81.56 TO STA. 1785+01.31
- SR 1 SOUTHBOUND OUTSIDE SHOULDER: STA. 1786+66.96 TO STA. 1786+86.71
- SR 1 SOUTHBOUND INSIDE SHOULDER: STA. 1790+21.41 TO STA. 1790+41.16
- SR 1 NORTHBOUND OUTSIDE SHOULDER: STA. 1799+75.58 TO STA. 1799+95.33
- SR 1 NORTHBOUND INSIDE SHOULDER: STA. 1809+23.38 TO STA. 1809+43.13
- SR 1 SOUTHBOUND OUTSIDE SHOULDER: STA. 1817+79.55 TO STA. 1817+99.30

- NOTES:**
- PLACE PREFORMED EXPANSION JOINT MATERIAL BETWEEN END OF CURB AND BARRIER PER SECTION 701.03.
 - TRANSITION LIMITS TO BE MEASURED FOR PAYMENT UNDER ITEM 701016 WITH ALL COSTS FOR TRANSITION INCLUDED IN ITEM 701016.

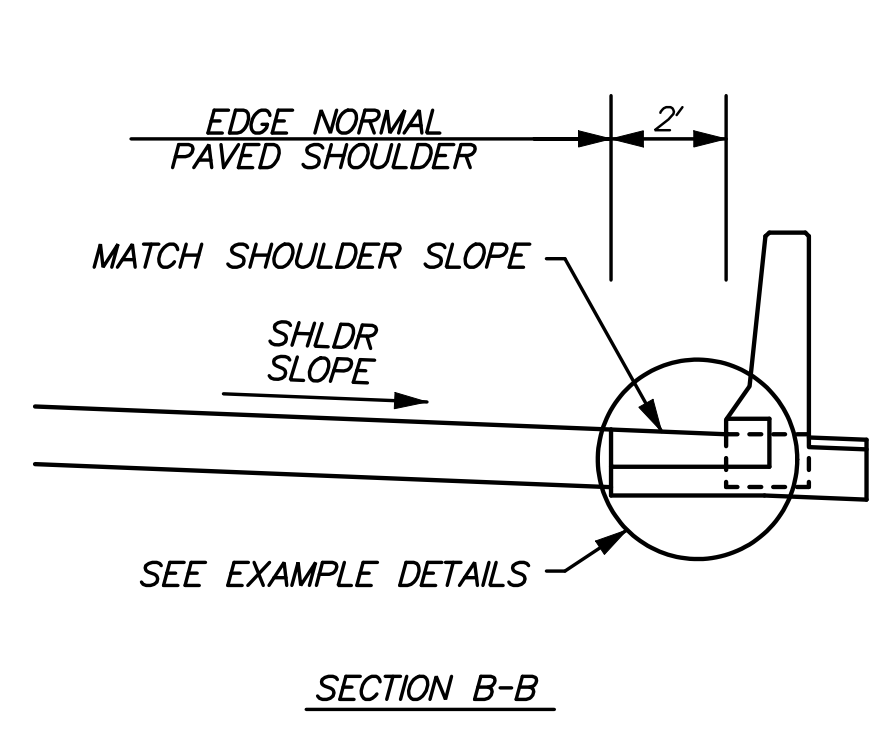
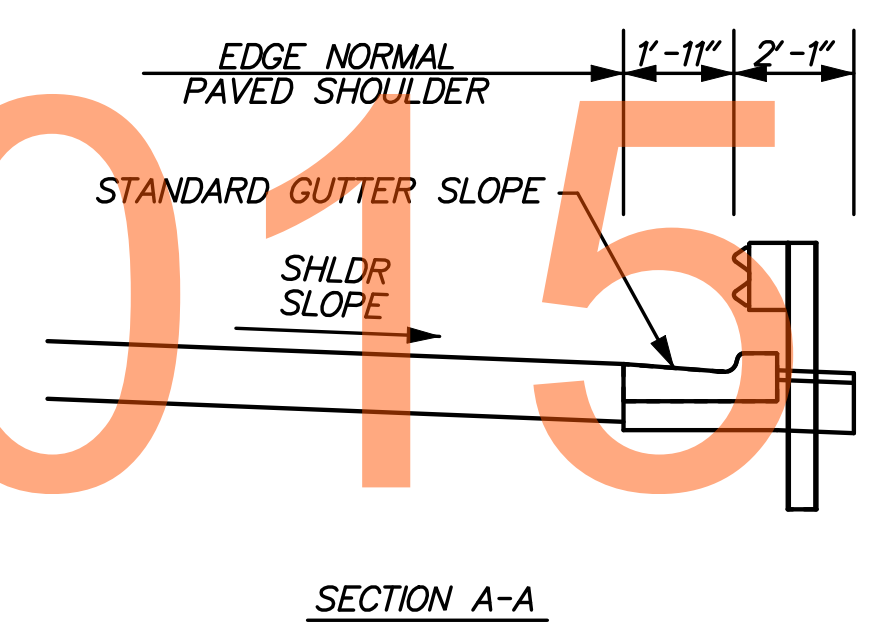

REINFORCED CONCRETE FLARED END SECTION
12" - 33" DIAMETER

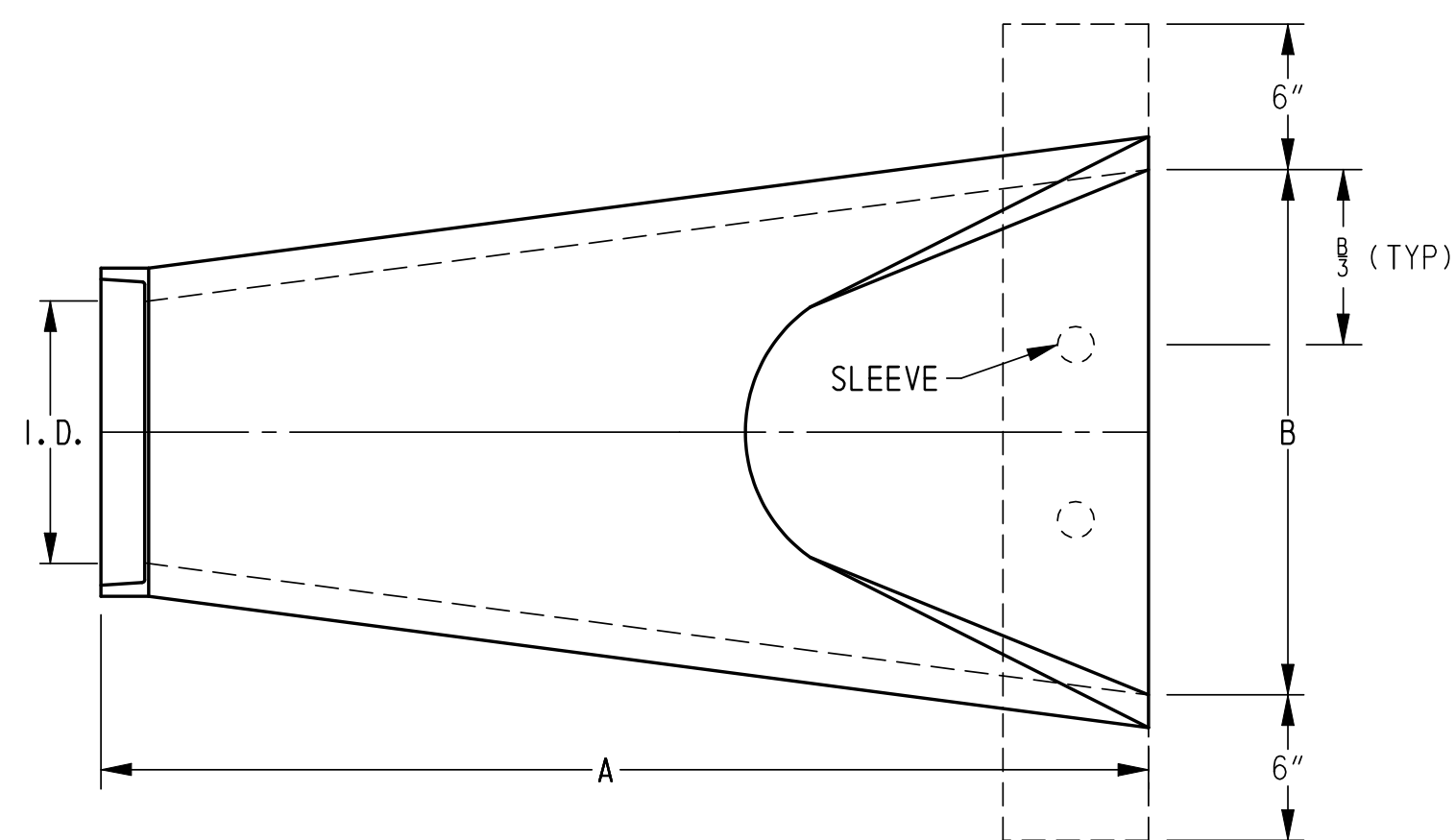

SEE CUTOFF WALL DETAIL
PLAN VIEW

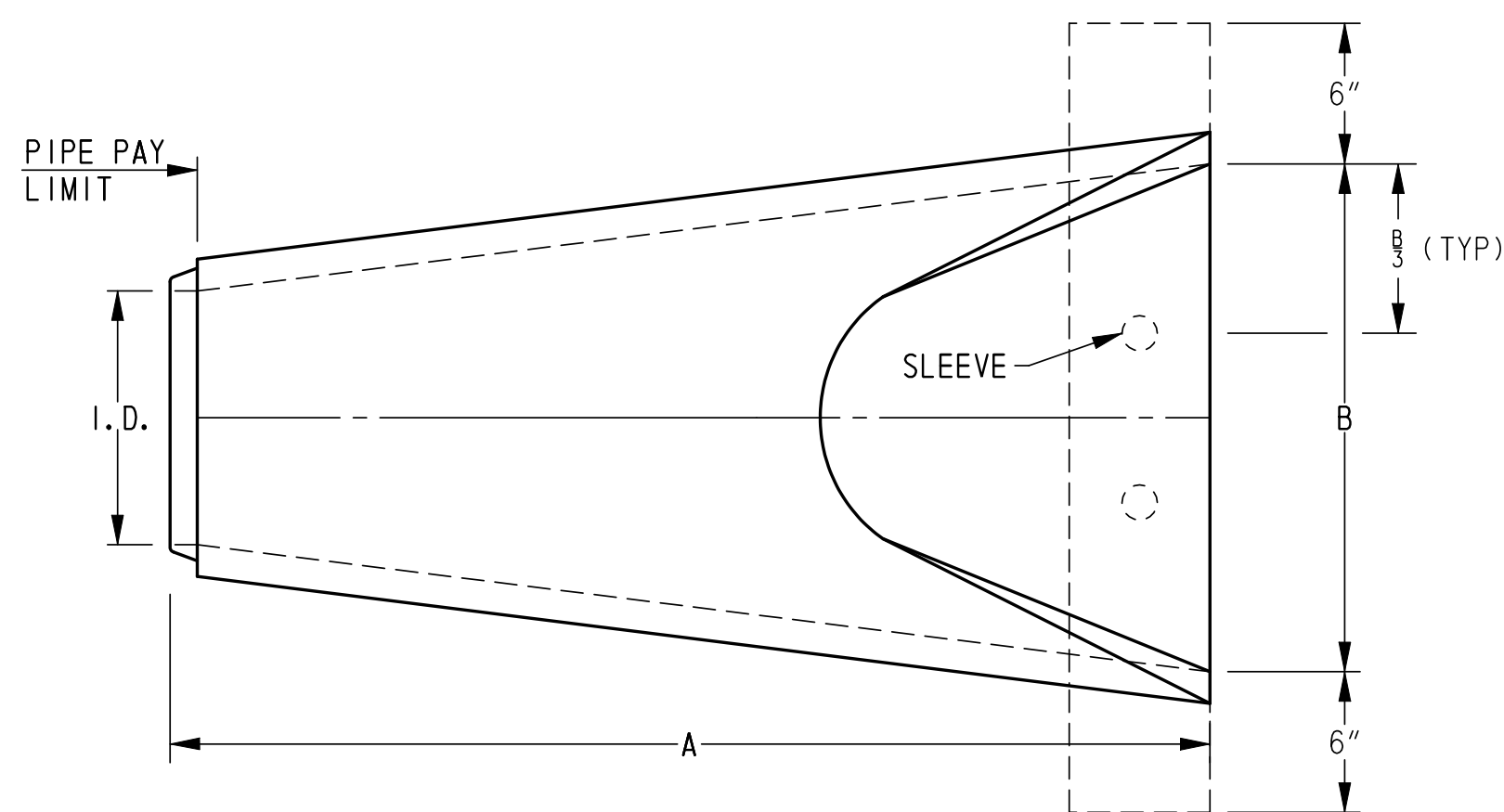

SEE CUTOFF WALL DETAIL
PLAN VIEW

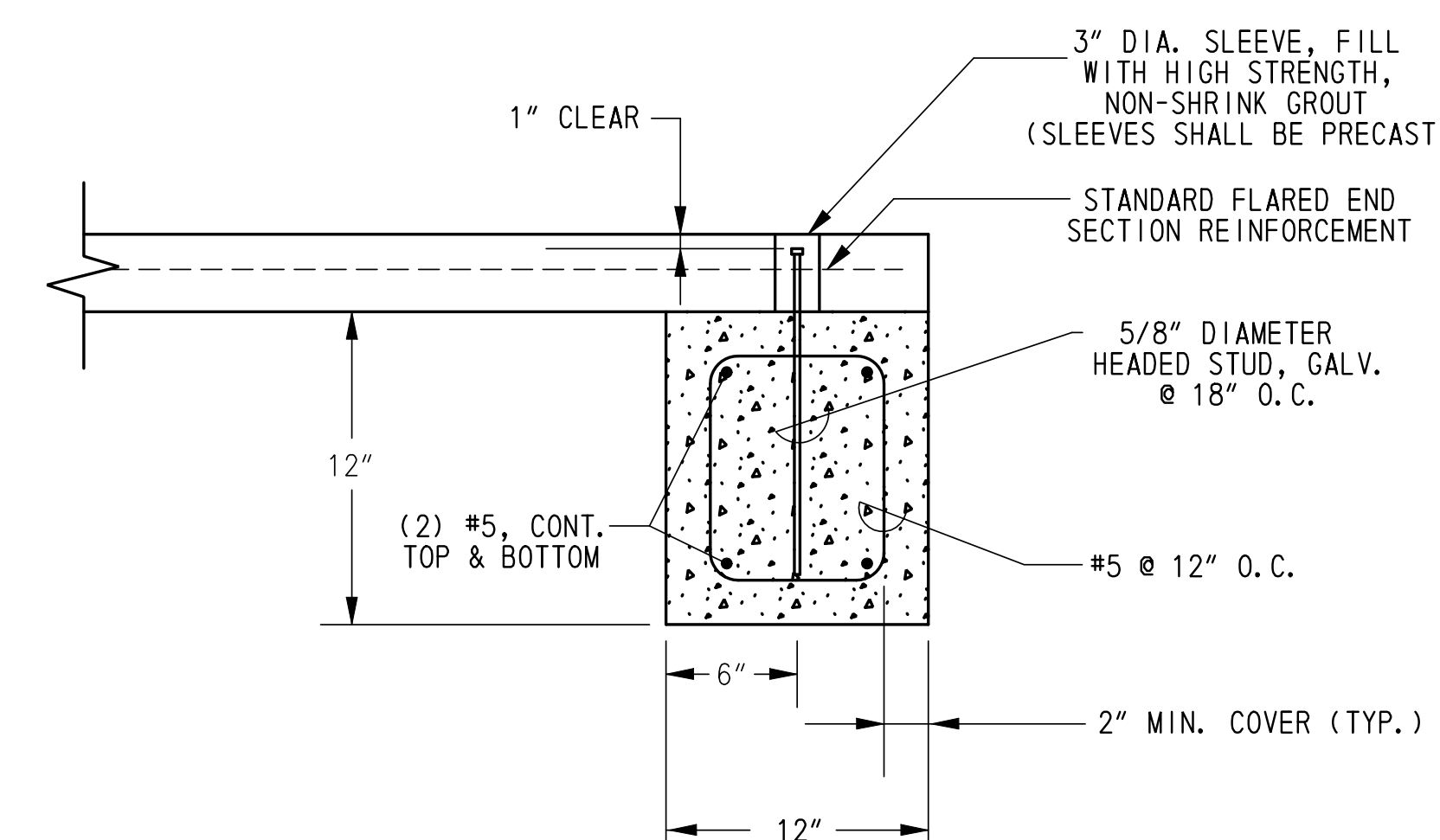

CUTOFF WALL DETAIL
N. T. S.

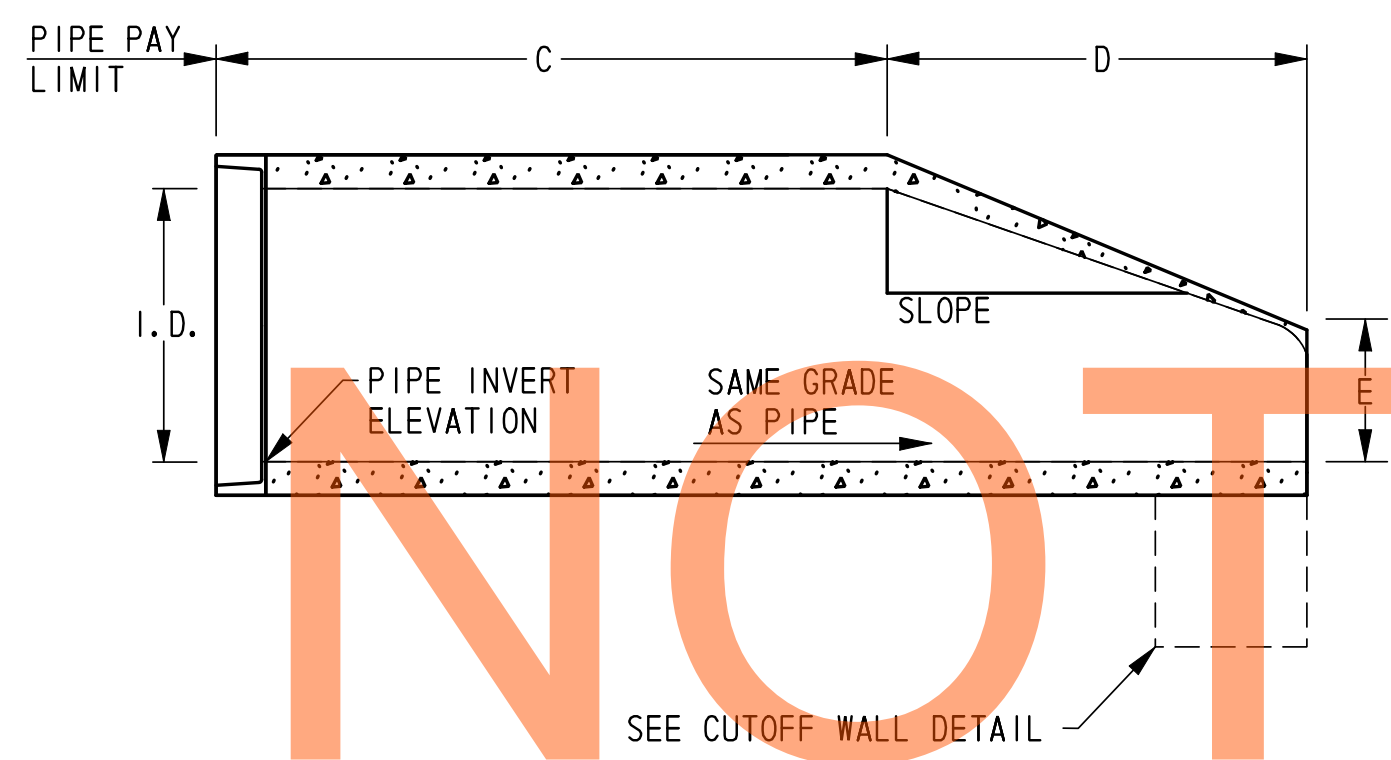

FLARED END SECTION - OUTLET
N. T. S.

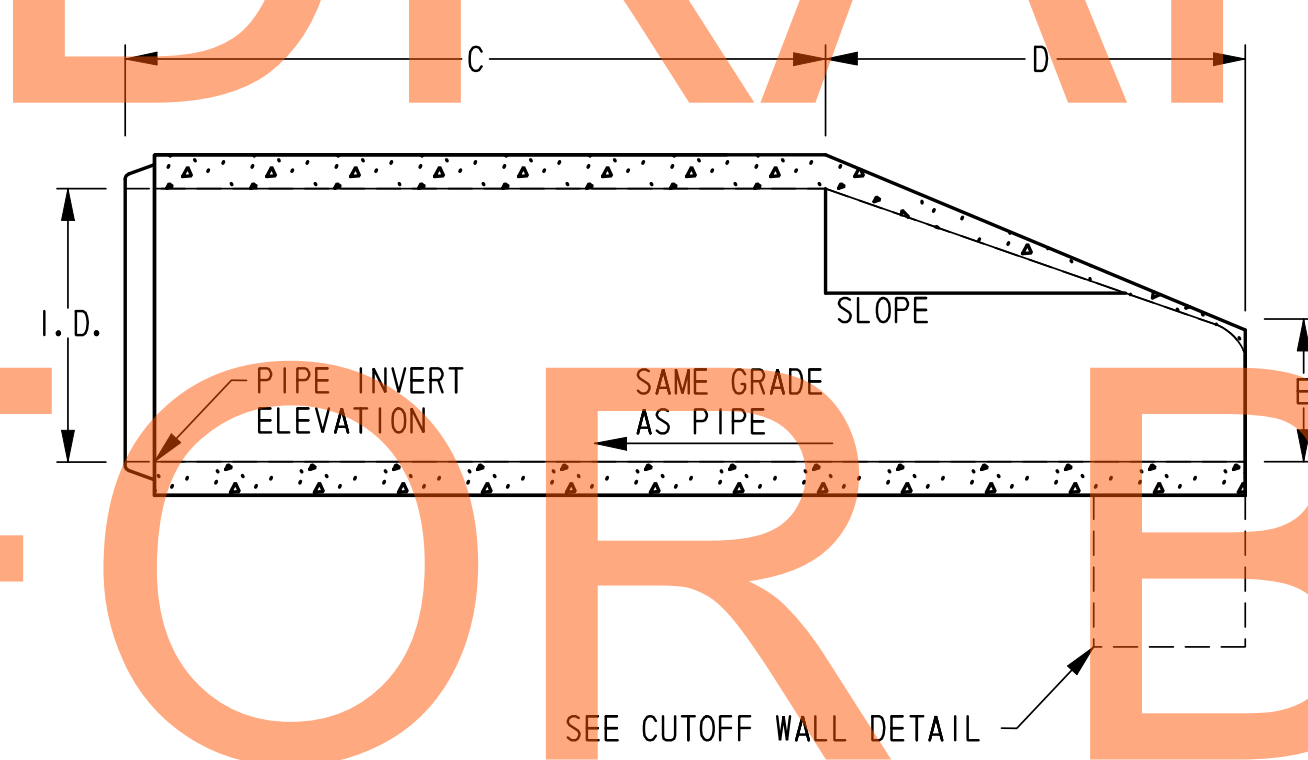

FLARED END SECTION - INLET
N. T. S.

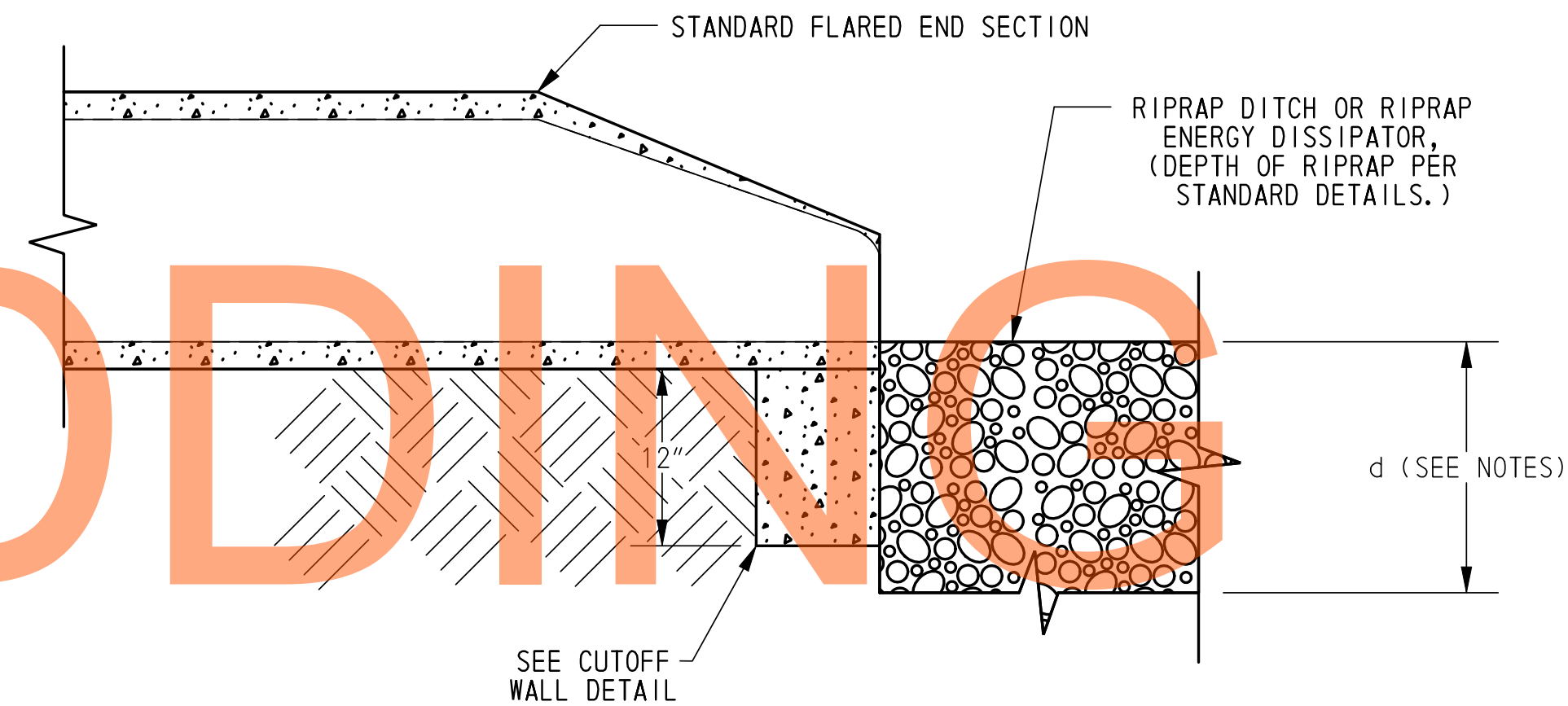

SIDE VIEW WITH OUTLET PROTECTION
N. T. S.

DRAFT
NOT FOR BIDDING
AUGUST 2015

PIPE I.D.	SLOPE	WALL	A (INCHES)	B (INCHES)	C (INCHES)	D (INCHES)	E (INCHES)
12	3:1	2	69	24	48	21	5
15	3:1	2 1/4	73	30	46	27	6
18	3:1	2 1/2	73	36	46	27	9
21	3:1	2 3/4	74	42	38	36	9
24	3:1	3	72 1/2	48	29	43 1/2	9 1/2
27	3:1	3 1/4	75	54	25 1/2	49 1/2	10 1/2
30	3:1	3 1/2	73 3/4	60	19 3/4	54	12
33	3:1	3 3/4	81	66	26	55	14

NOTES:

- FLARED END SECTIONS SHALL BE MANUFACTURED TO ASTM C-76 AND AASHTO M-170 WITH CLASS III REINFORCEMENT.
- FLARED END SECTIONS SHALL BE BEDDED IN ACCORDANCE WITH DELDOT STANDARD SPECIFICATION 612, REINFORCED CONCRETE PIPE.
- FLARED END SECTIONS 27 INCHES AND LARGER SHALL INCLUDE A 12 INCH WIDE CUTOFF WALL CONSTRUCTED AS SHOWN. CUTOFF WALL MAY BE CAST-IN-PLACE OR PRECAST CLASS B CONCRETE. ALL COSTS FOR THE CUTOFF WALL SHALL BE INCIDENTAL TO THE FLARED END SECTION.
- DEPTH OF RIPRAP (d) PER STANDARD DETAILS.

M:\31653-000\CONTRACT 18\CADD\DT008U30_L1B.dgn

ADDENDUMS / REVISIONS	

NOT TO SCALE

US 301 &
SR 1 INTERCHANGE

CONTRACT T200911302	BRIDGE NO.
COUNTY NEW CASTLE	DESIGNED BY: KAH
	CHECKED BY: BRT

CONSTRUCTION DETAILS

DT-08
SHEET NO. 91
TOTAL SHTS. 491

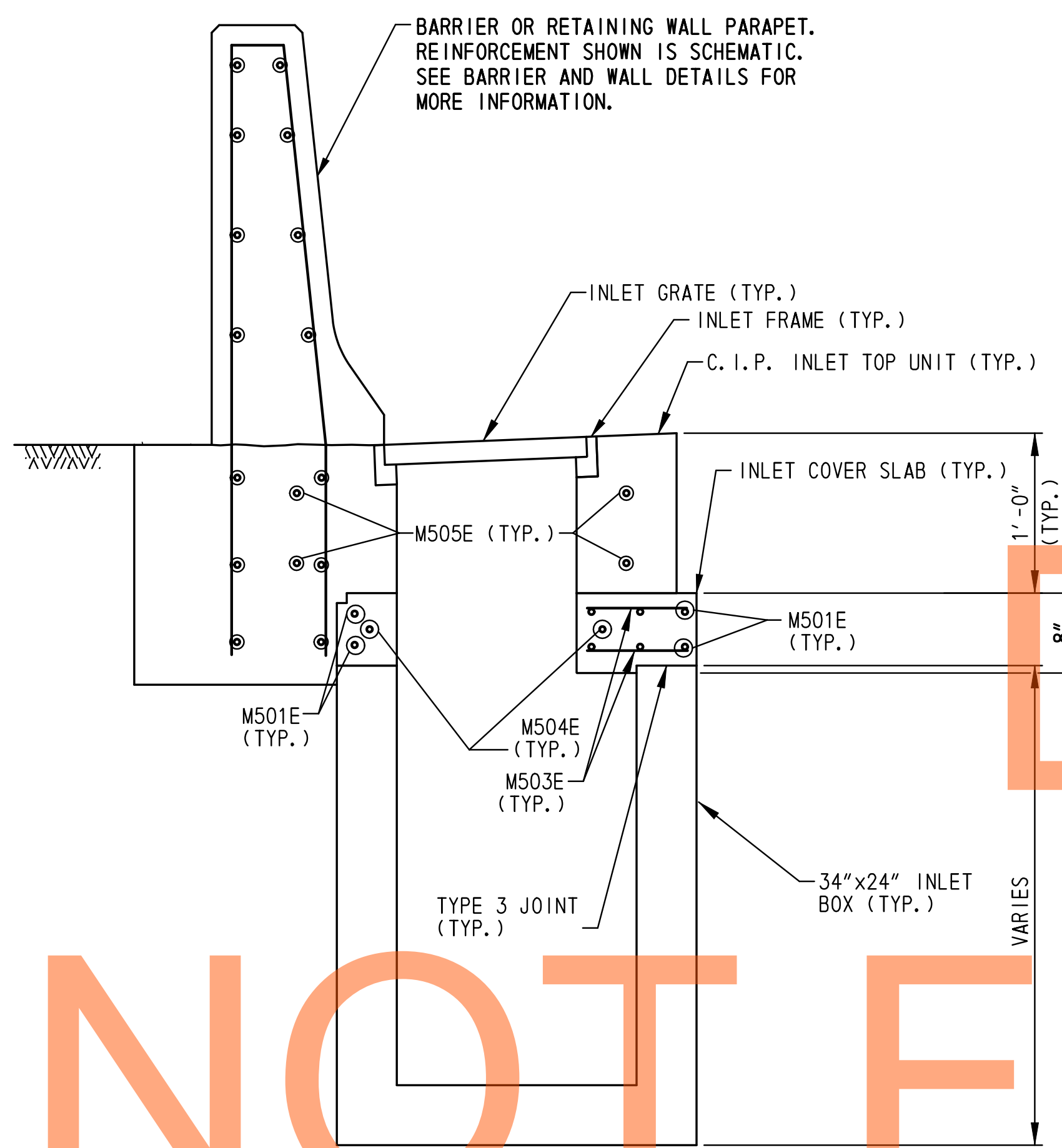

34" X 24" DRAINAGE INLET ASSEMBLY
SCALE: 1" = 1'-0"

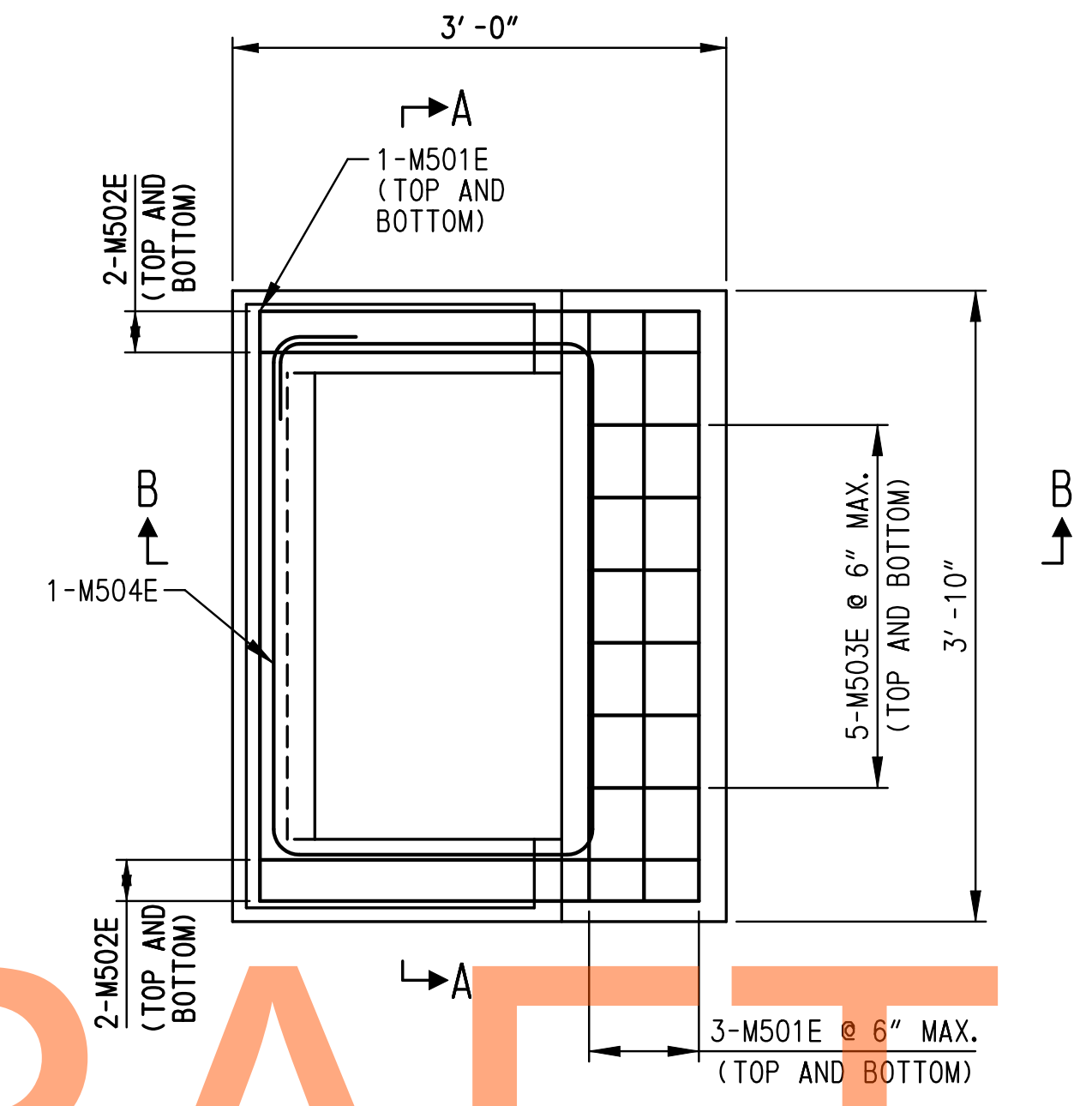

INLET COVER SLAB DETAIL
SCALE: 1" = 1'-0"

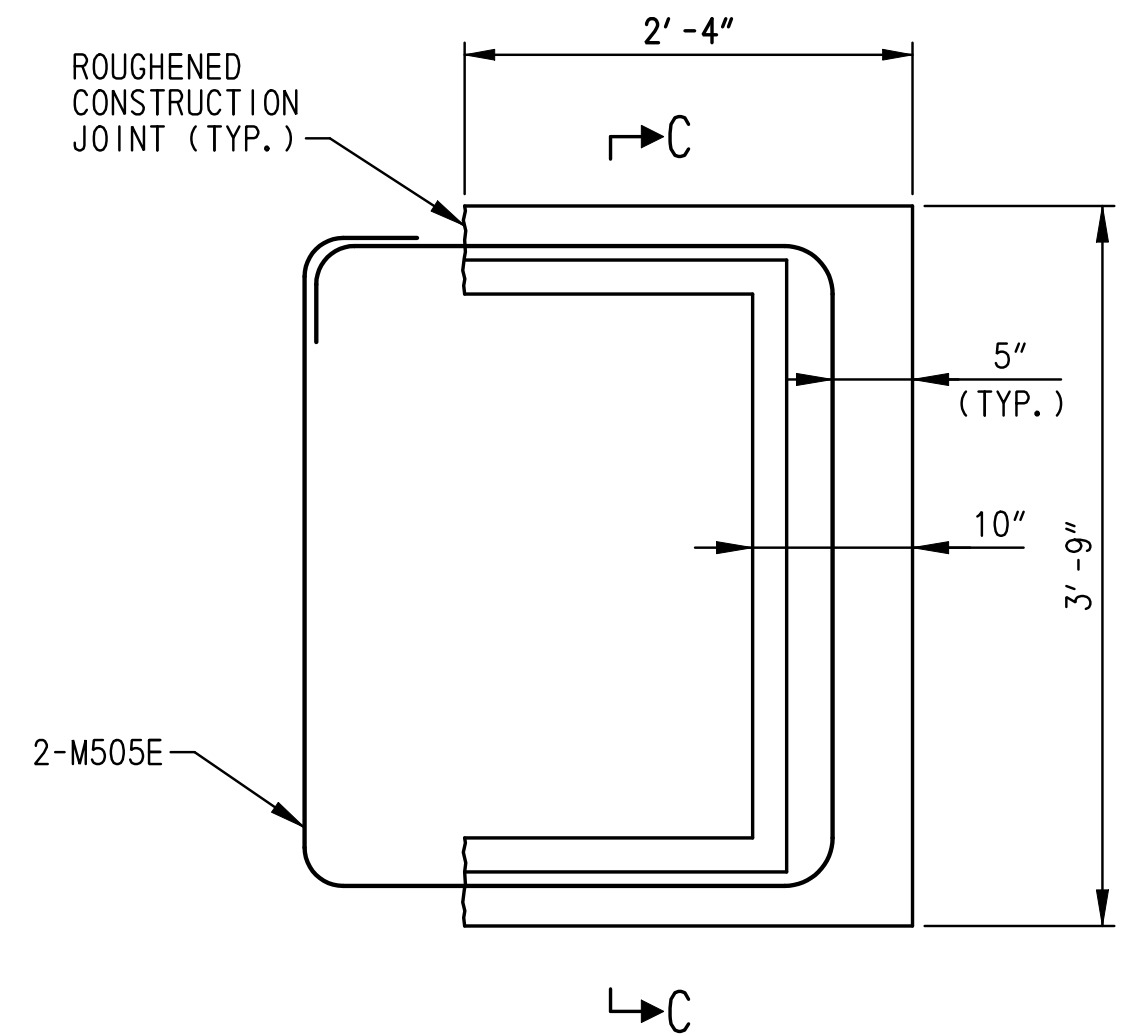

INLET TOP UNIT DETAIL
SCALE: 1" = 1'-0"

NOTES:

1. PAYMENT FOR DRAINAGE INLETS INCLUDING BOXES, GRATES, TOP UNITS, COVER SLABS, MODIFICATIONS TO CONCRETE BARRIER, JOINT SEALANT AND ALL WORK ASSOCIATED WITH DRAINAGE INLET ASSEMBLIES WILL BE MADE UNDER ITEM NO. 708051 - DRAINAGE INLET, 34" X 24".
2. FOR DRAINAGE INLET ASSEMBLY LOCATIONS SEE CONSTRUCTION PLANS.
3. SEE STANDARD NO. D-4 FOR INLET BOX DETAILS. SEE STANDARD NO. D-5 FOR GRATE, FRAME, AND JOINT DETAILS.
4. MINIMUM REINFORCEMENT COVER SHALL BE 1 1/2".
5. HOT POURED JOINT SEALANT SHALL BE USED TO FILL THE GAP BETWEEN THE DRAINAGE INLET FRAMES.

DRAFT

NOT FOR BIDDING

AUGUST 2015

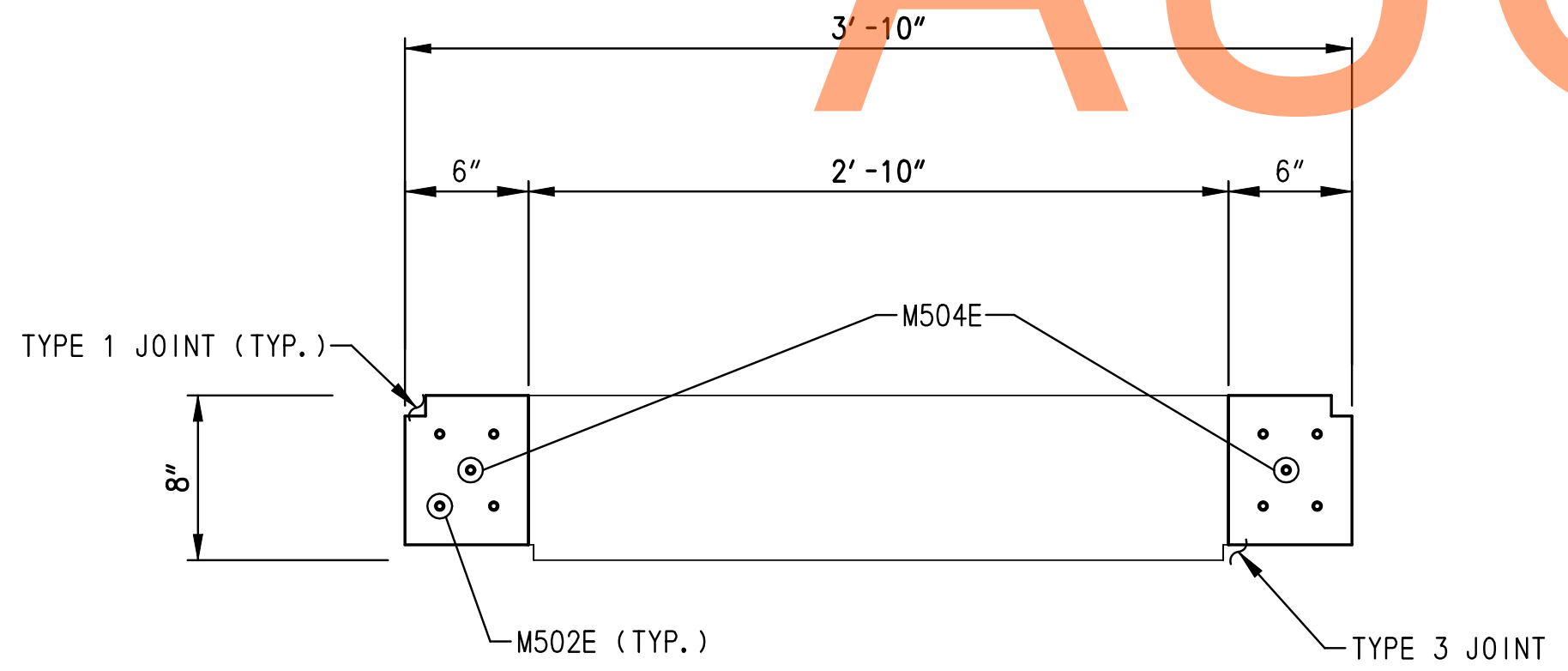

SECTION A-A
SCALE: 1 1/2" = 1'-0"

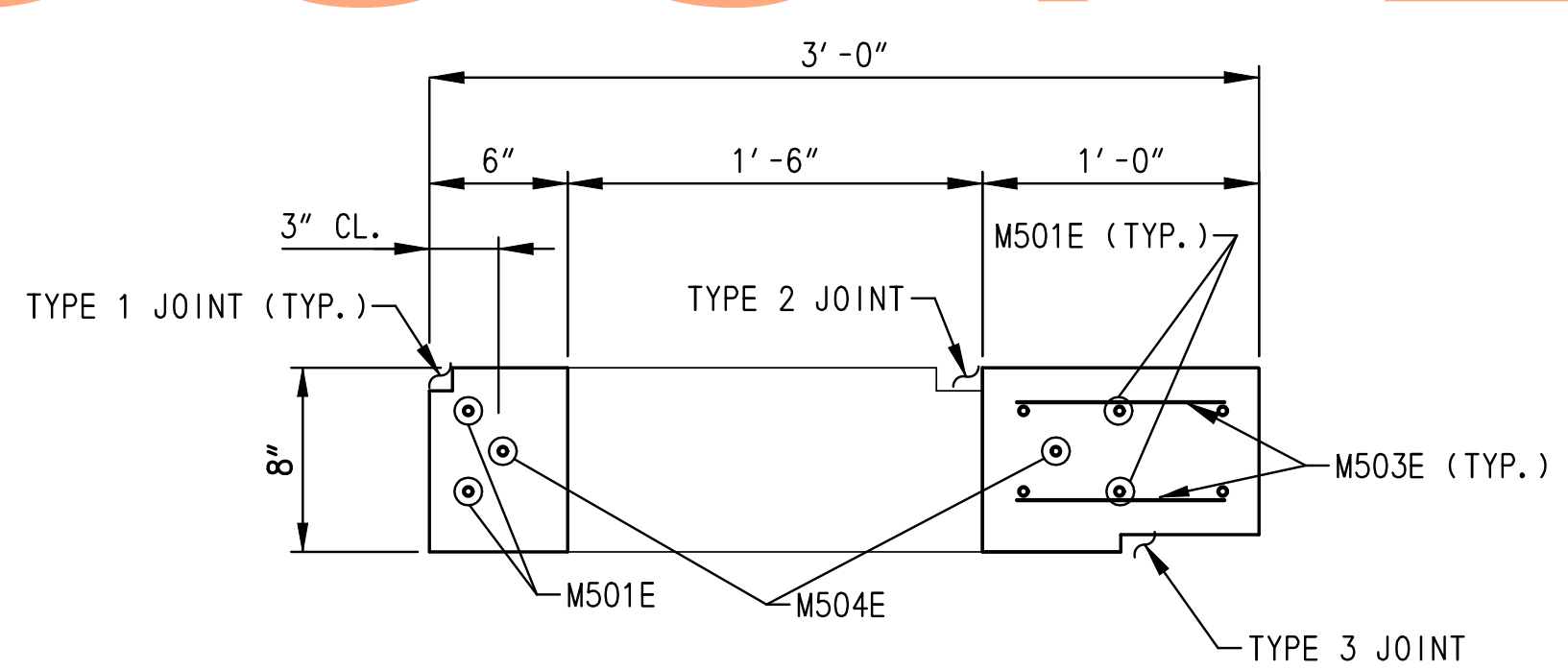

SECTION B-B
SCALE: 1 1/2" = 1'-0"

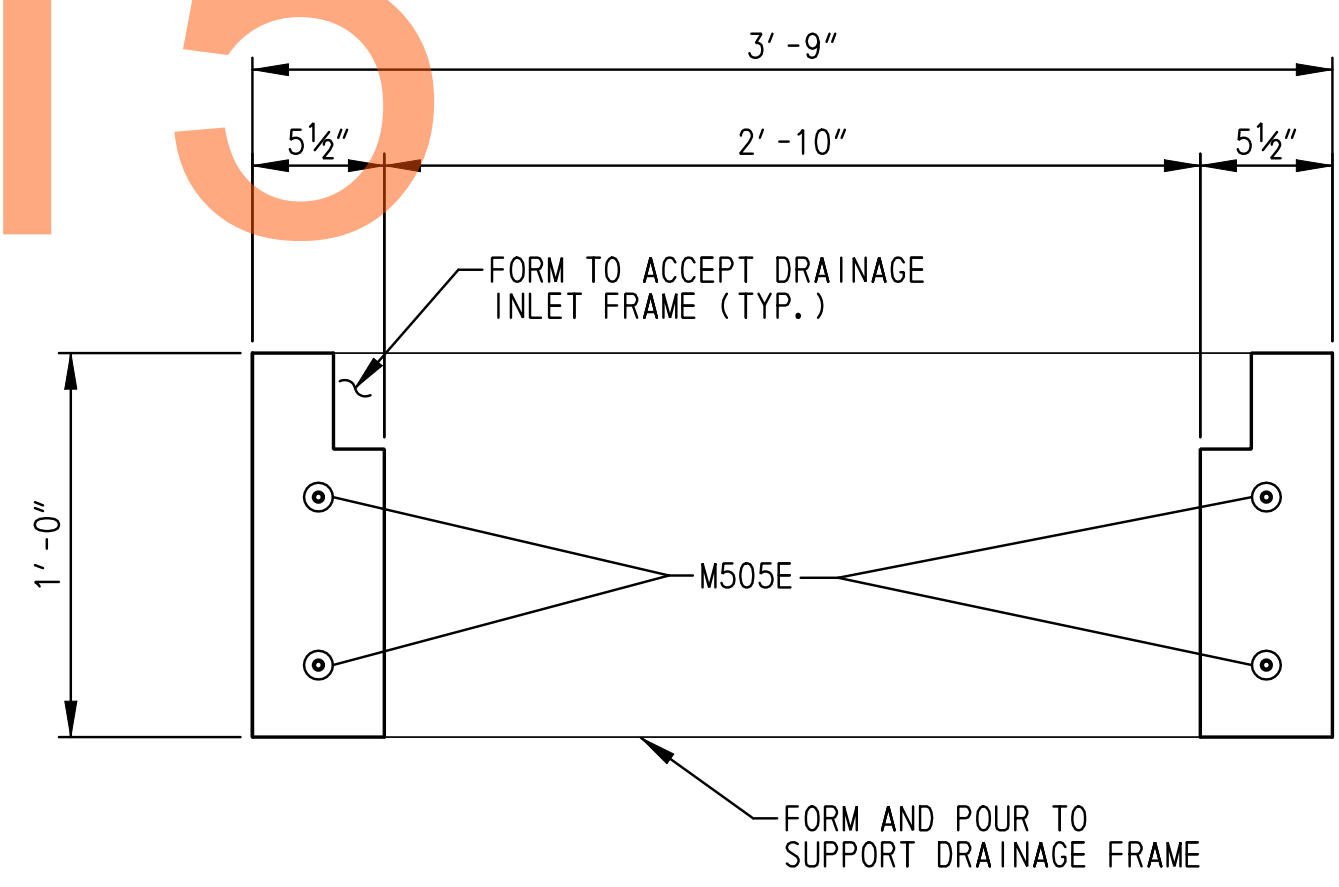

SECTION C-C
SCALE: 1 1/2" = 1'-0"

M:\31653-000\CONTRACT 18\CAD\DT00910301_IB.dgn 7/27/2015 7:42:20 AM

ADDENDUMS / REVISIONS	

CONTRACT T200911302	BRIDGE NO.
COUNTY NEW CASTLE	DESIGNED BY: K.M.K.
	CHECKED BY: B.K.B.

DT-09
SHEET NO. 92
TOTAL SHTS. 491

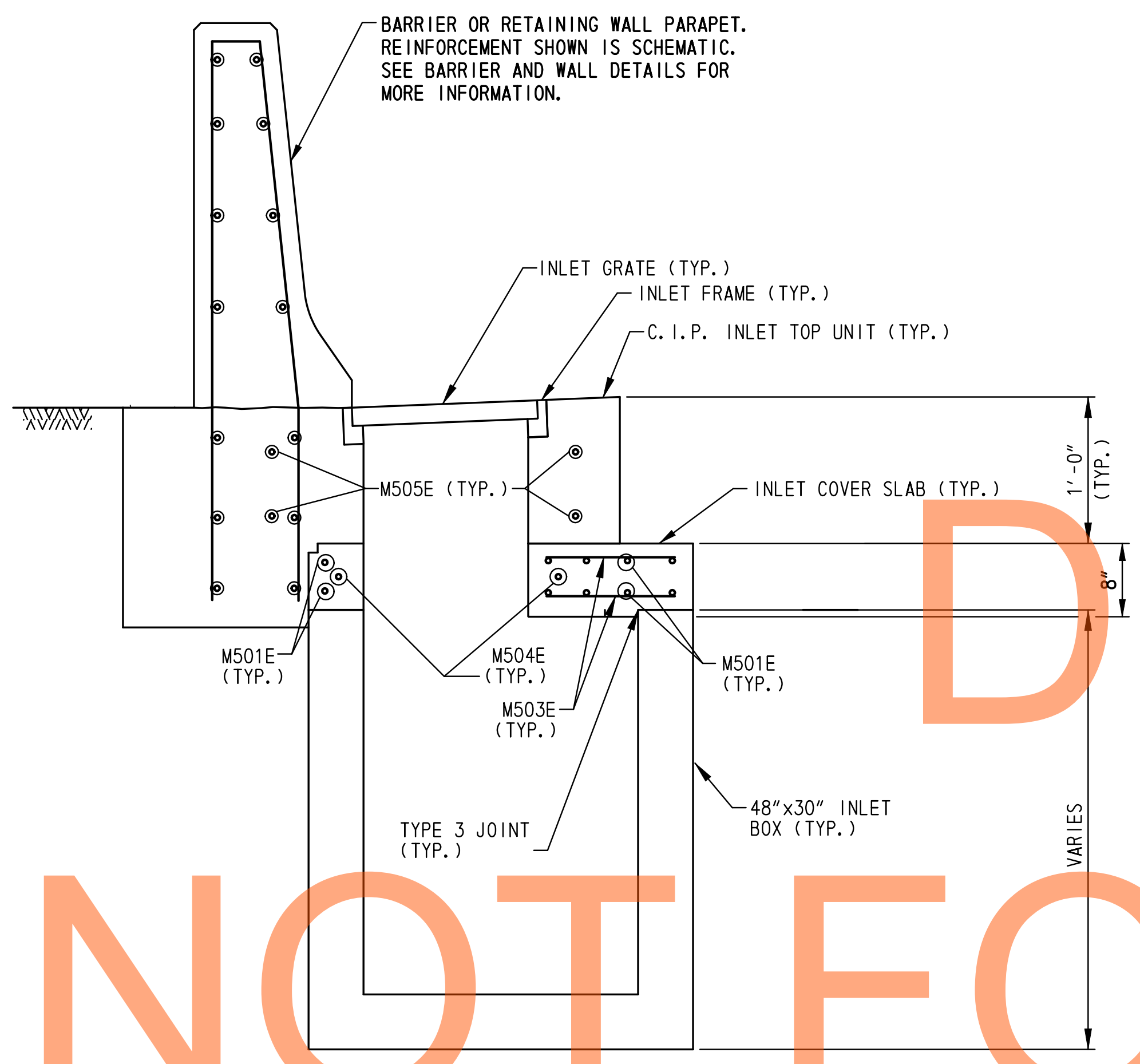

48" X 30" DRAINAGE INLET ASSEMBLY
SCALE: 1" = 1' - 0"

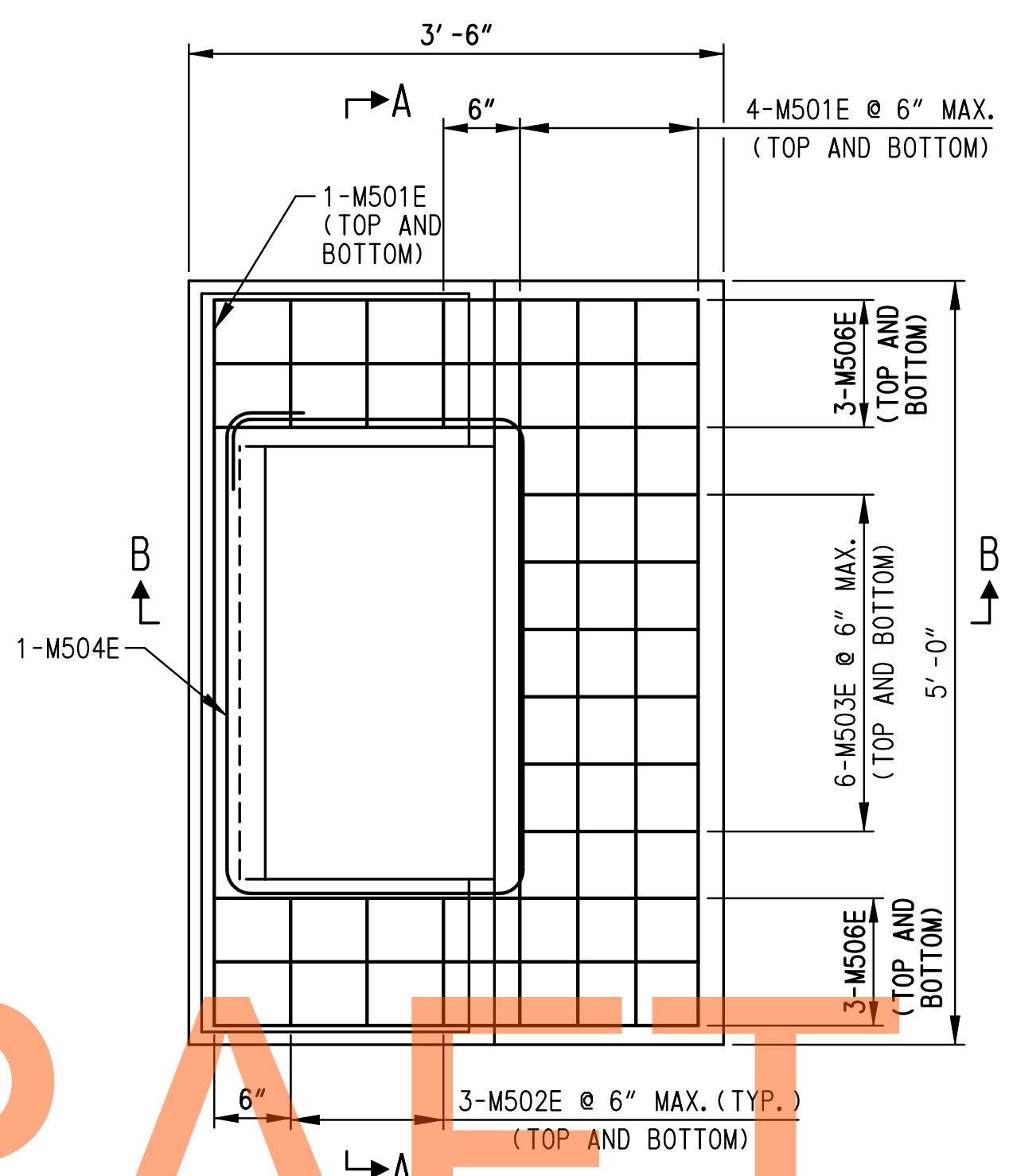

INLET COVER SLAB DETAIL
SCALE: 1" = 1' - 0"

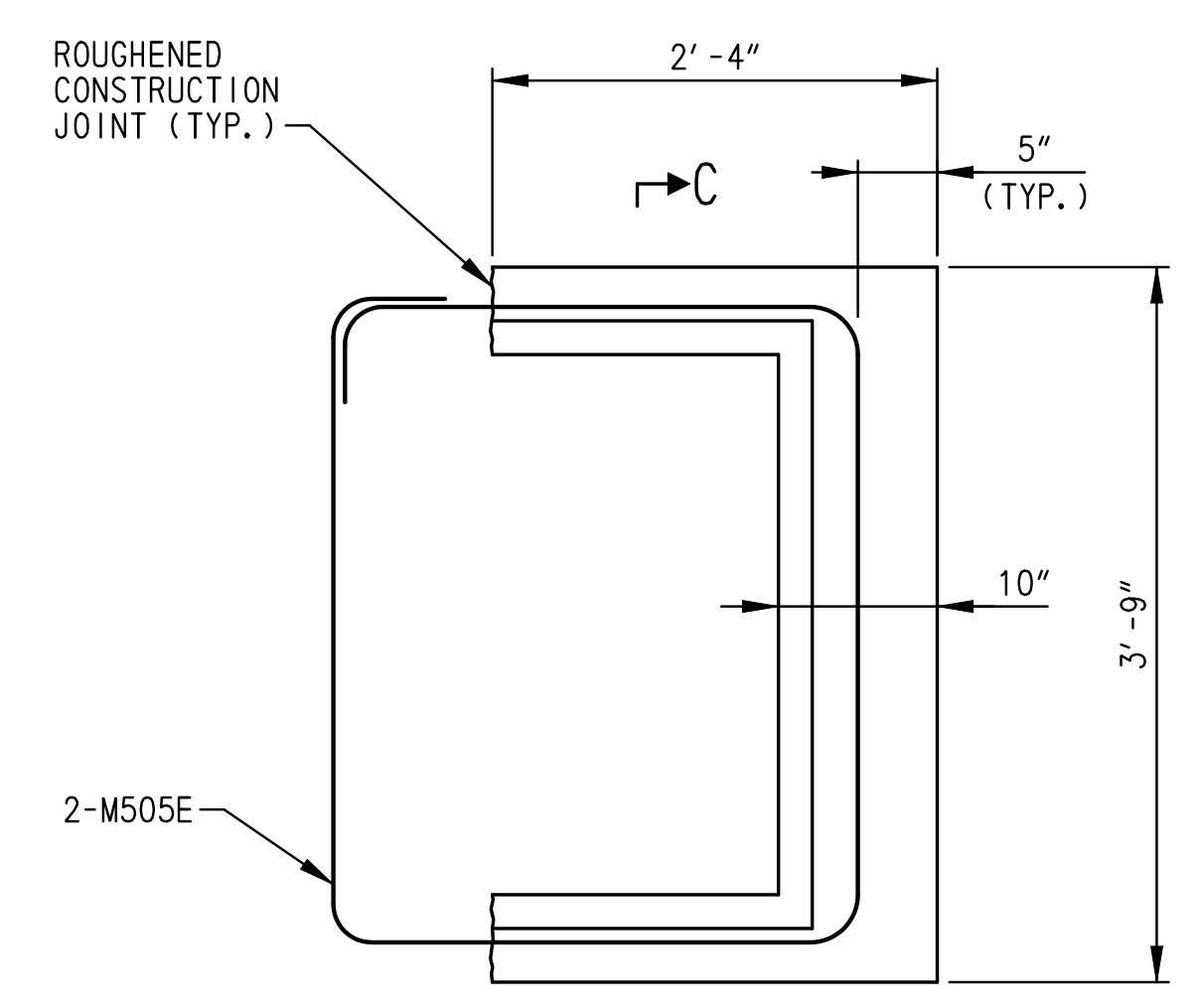

INLET TOP UNIT DETAIL
SCALE: 1" = 1' - 0"

NOTES:

1. PAYMENT FOR DRAINAGE INLETS INCLUDING BOXES, GRATES, TOP UNITS, COVER SLABS, MODIFICATIONS TO CONCRETE MEDIAN BARRIER, JOINT SEALANT AND ALL WORK ASSOCIATED WITH DRAINAGE INLET ASSEMBLIES WILL BE MADE UNDER ITEM NO. 708052 - DRAINAGE INLET, 48" X 48".
2. FOR DRAINAGE INLET ASSEMBLY LOCATIONS SEE CONSTRUCTION PLANS.
3. SEE STANDARD NO. D-4 FOR INLET BOX DETAILS. SEE STANDARD NO. D-5 FOR GRATE, FRAME, AND JOINT DETAILS.
4. MINIMUM REINFORCEMENT COVER SHALL BE 1 1/2".
5. HOT POURED JOINT SEALANT SHALL BE USED TO FILL THE GAP BETWEEN THE DRAINAGE INLET FRAMES.

DRAFT
NOT FOR BIDDING

AUGUST 2015

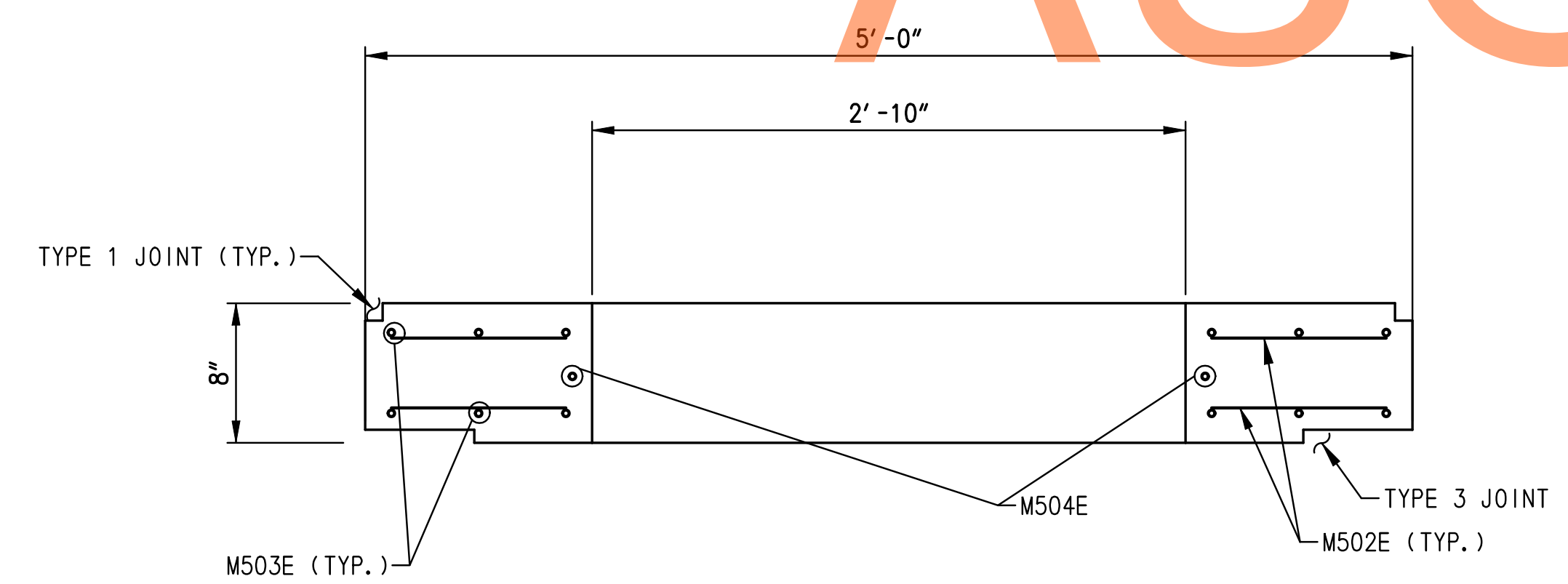

SECTION A-A
SCALE: 1 1/2" = 1' - 0"

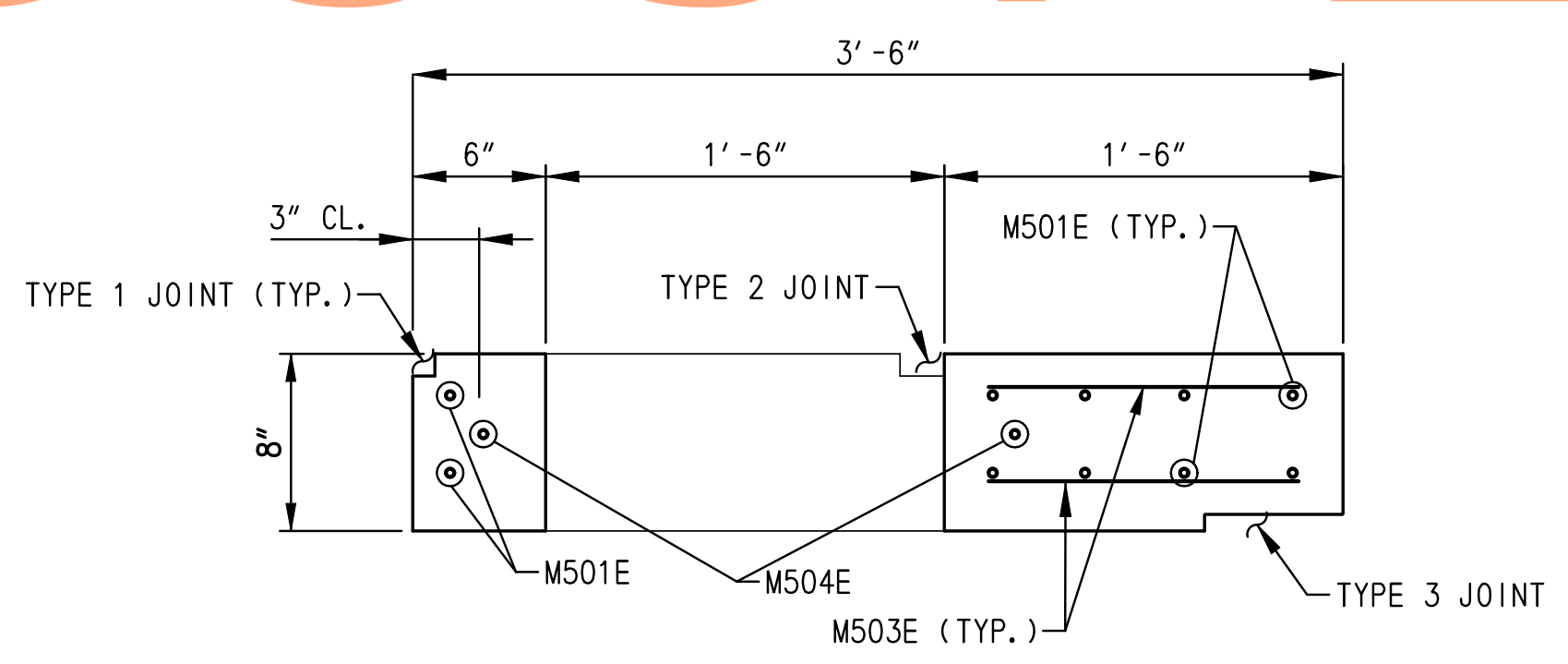

SECTION B-B
SCALE: 1 1/2" = 1' - 0"

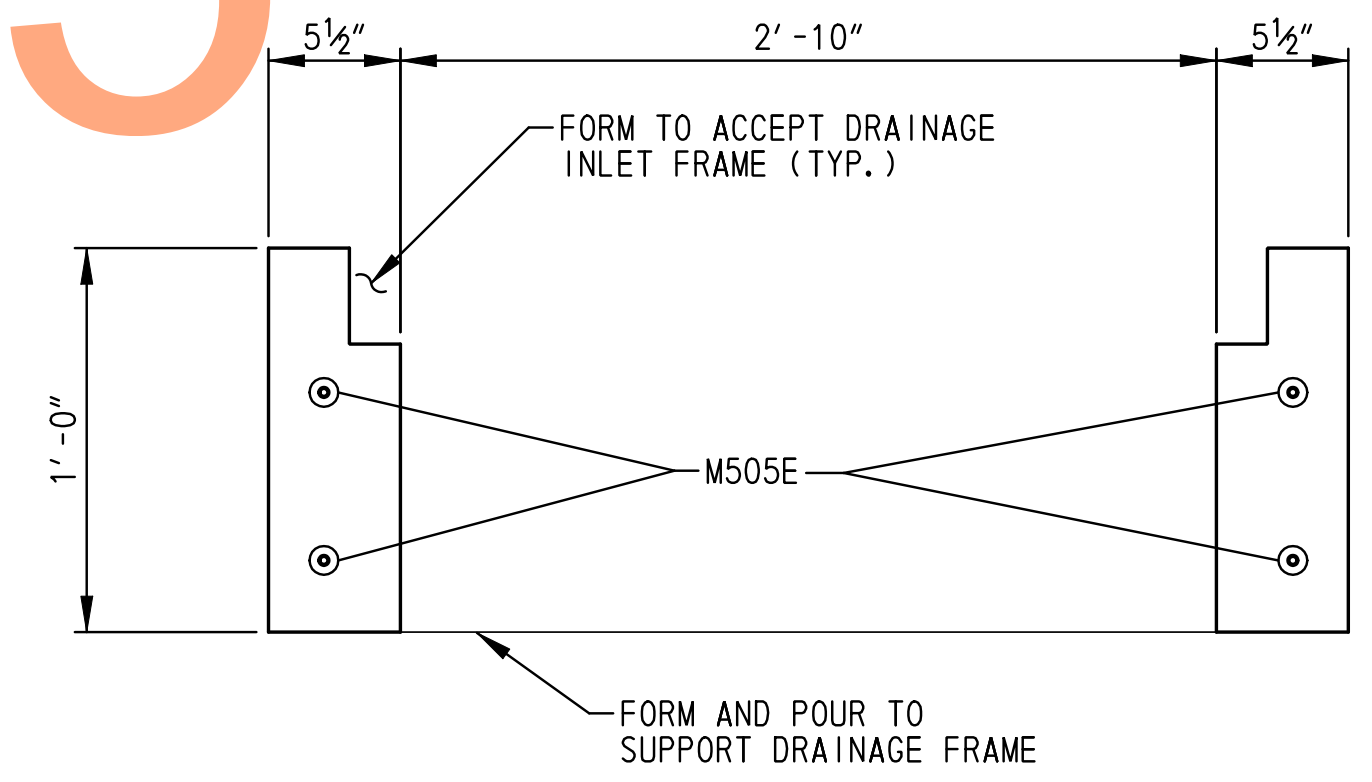

SECTION C-C
SCALE: 1 1/2" = 1' - 0"

p:\31653-000\contract_ib\cead\DT010030_LB.dgn 5/27/2015 1:42:27 AM

ADDENDUMS / REVISIONS	

CONTRACT T200911302	BRIDGE NO.
COUNTY NEW CASTLE	DESIGNED BY: K.M.K.
	CHECKED BY: B.K.B.

DT-10
SHEET NO. 93
TOTAL SHTS. 491

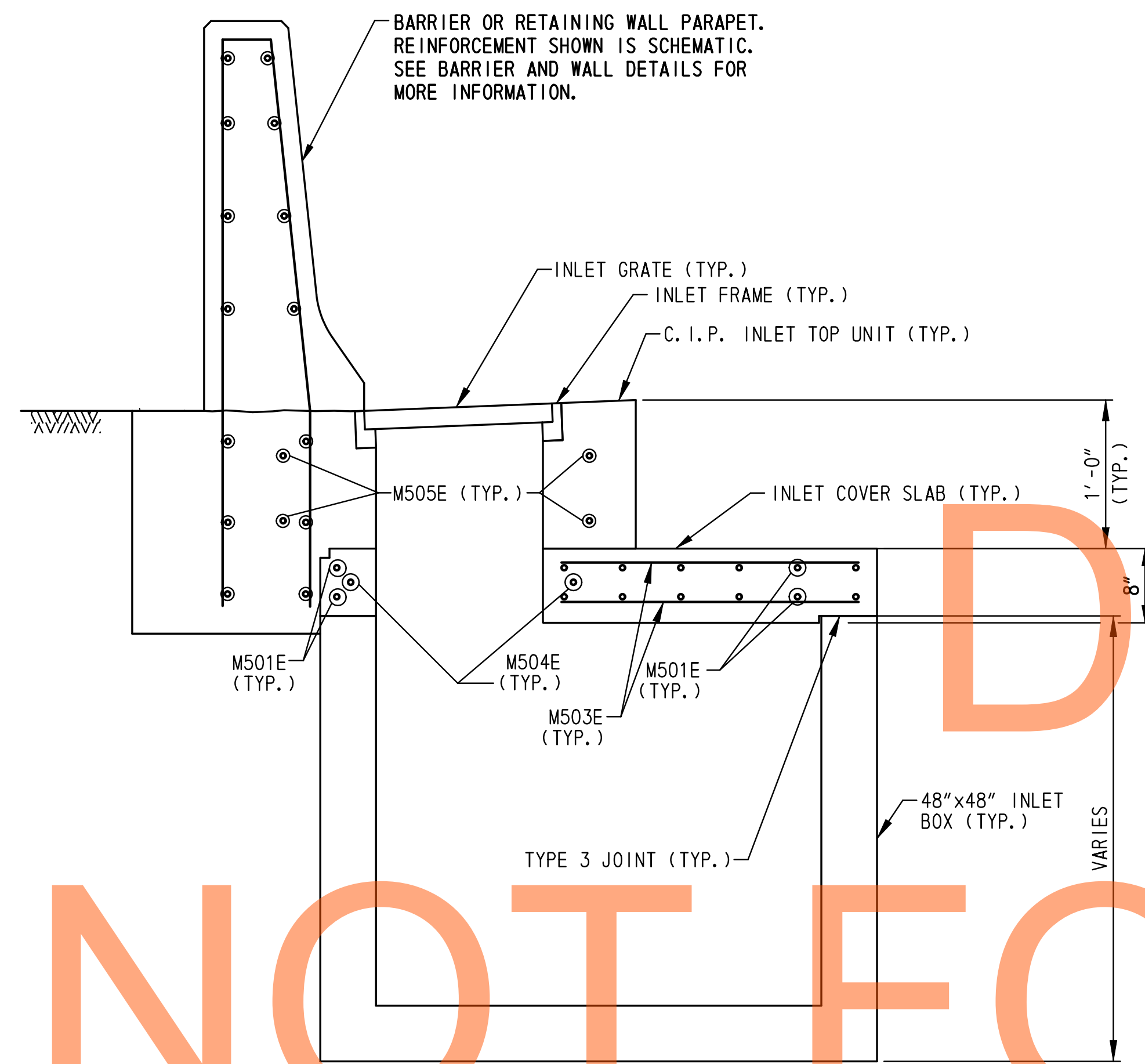

48" X 48" DRAINAGE INLET ASSEMBLY
SCALE: 1" = 1' - 0"

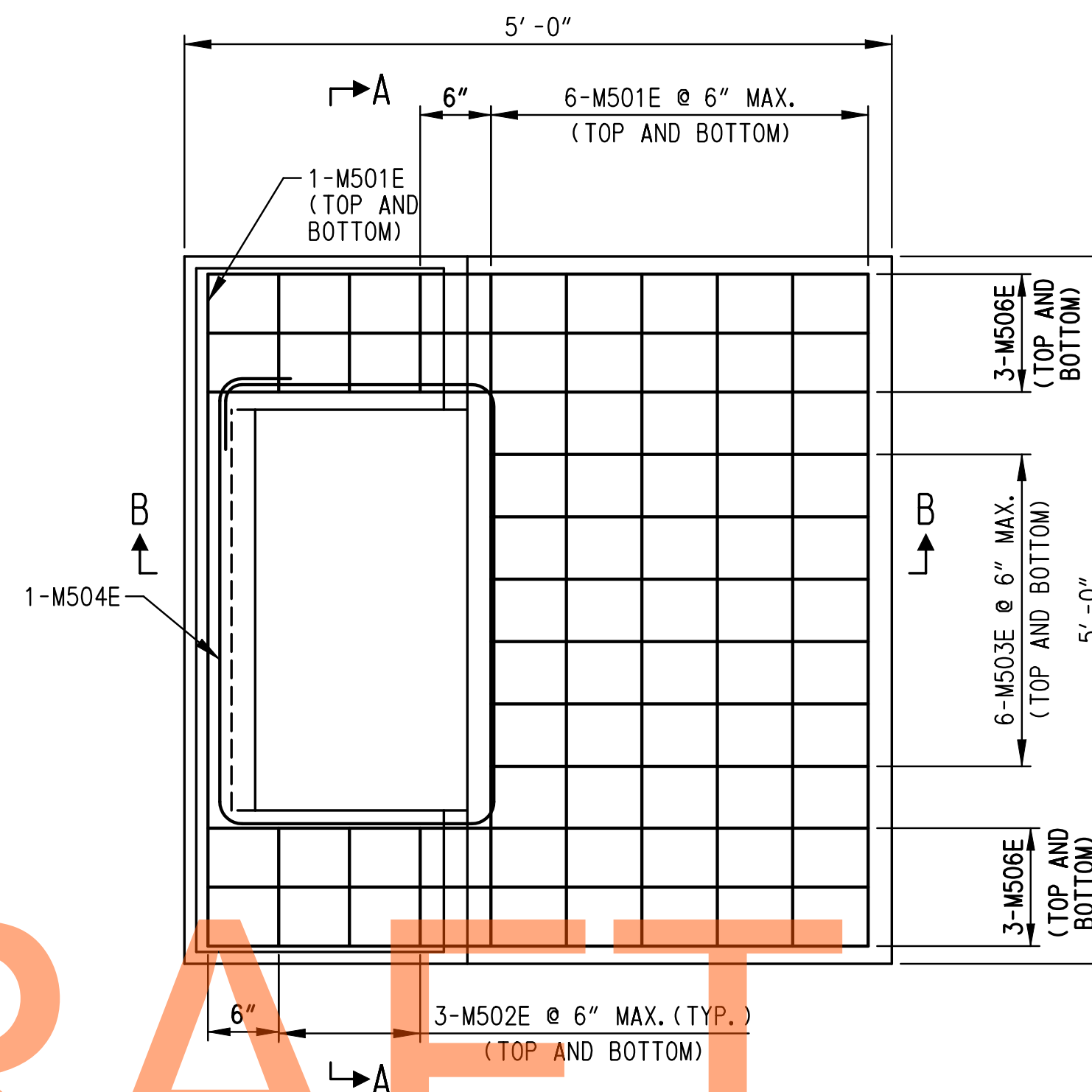

INLET COVER SLAB DETAIL
SCALE: 1" = 1' - 0"

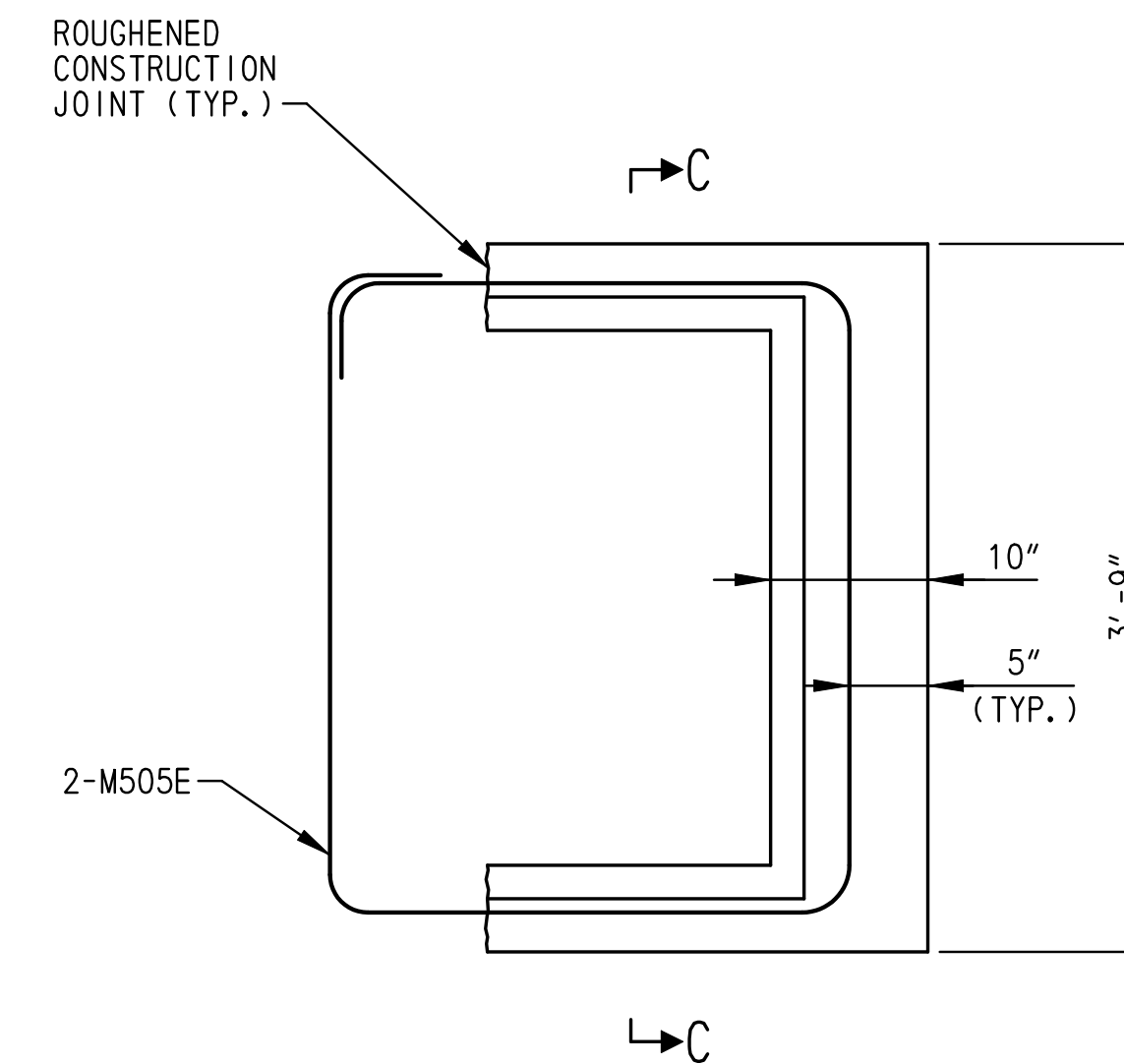

INLET TOP UNIT DETAIL
SCALE: 1" = 1' - 0"

NOTES:

- PAYMENT FOR DRAINAGE INLETS INCLUDING BOXES, GRATES, TOP UNITS, COVER SLABS, MODIFICATIONS TO CONCRETE MEDIAN BARRIER, JOINT SEALANT AND ALL WORK ASSOCIATED WITH DRAINAGE INLET ASSEMBLIES WILL BE MADE UNDER ITEM NO. 708053 - DRAINAGE INLET, 48" X 48".
- FOR DRAINAGE INLET ASSEMBLY LOCATIONS SEE CONSTRUCTION PLANS.
- SEE STANDARD NO. D-4 FOR INLET BOX DETAILS. SEE STANDARD NO. D-5 FOR GRATE, FRAME, AND JOINT DETAILS.
- MINIMUM REINFORCEMENT COVER SHALL BE 1 1/2".
- HOT POURED JOINT SEALANT SHALL BE USED TO FILL THE GAP BETWEEN THE DRAINAGE INLET FRAMES.

DRAFT

NOT FOR BIDDING

AUGUST 2015

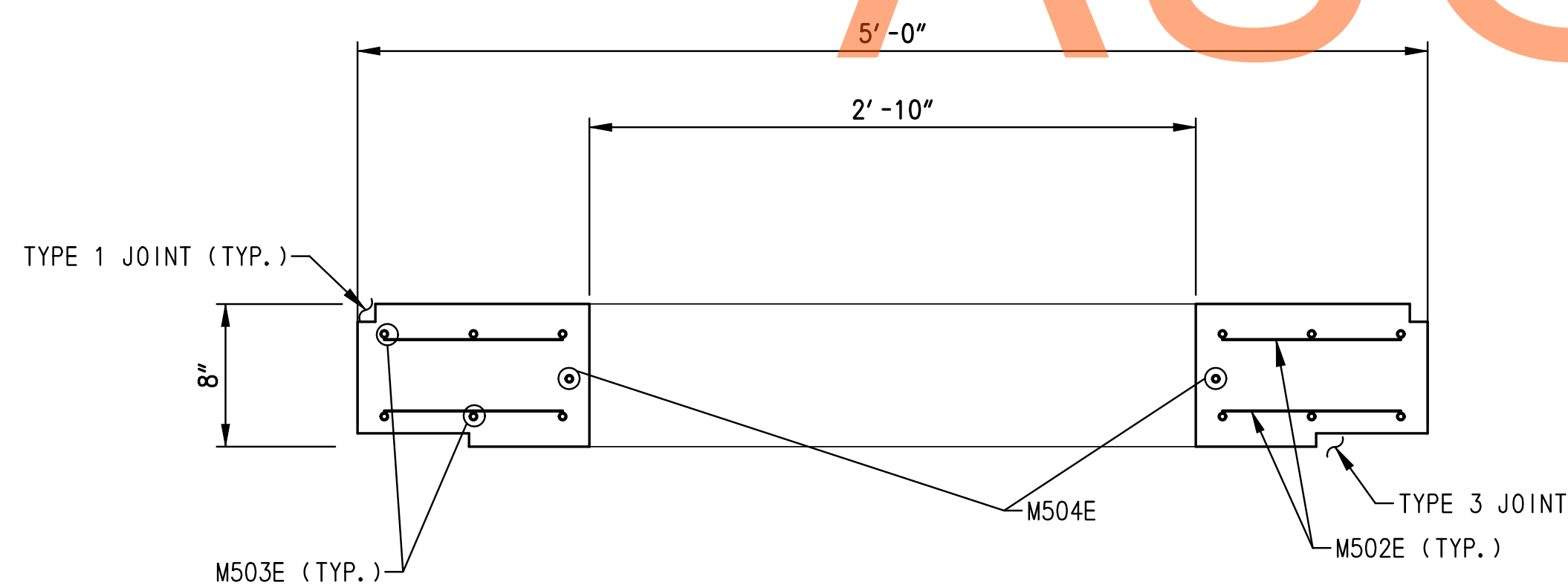

SECTION A-A
SCALE: 1 1/2" = 1' - 0"

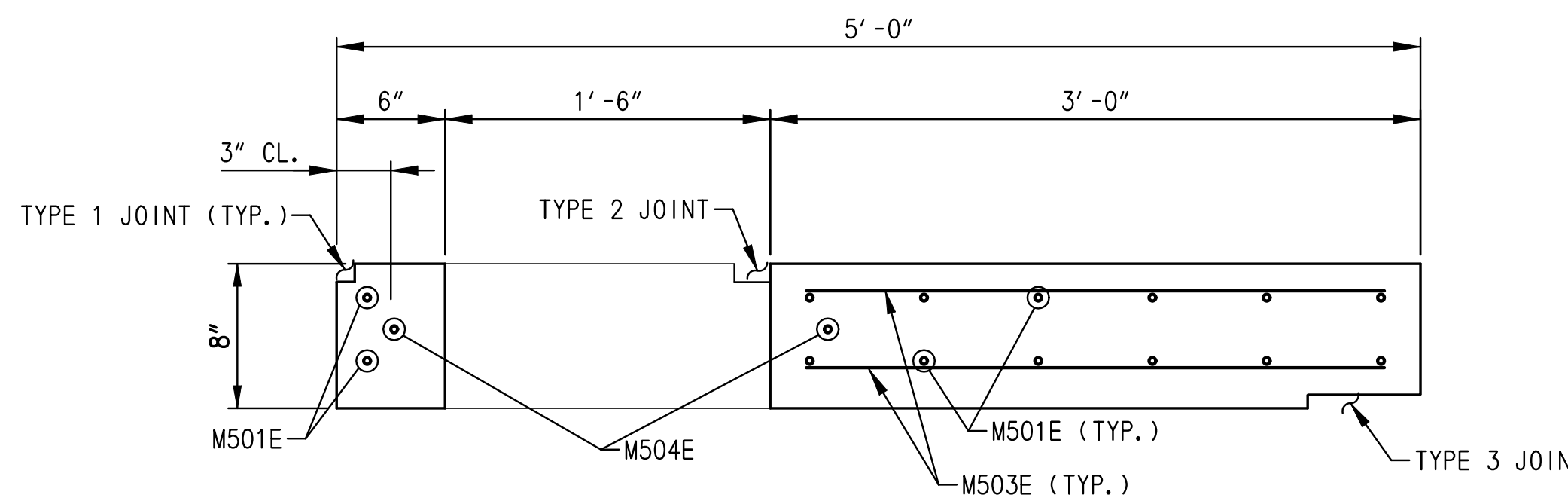

SECTION B-B
SCALE: 1 1/2" = 1' - 0"

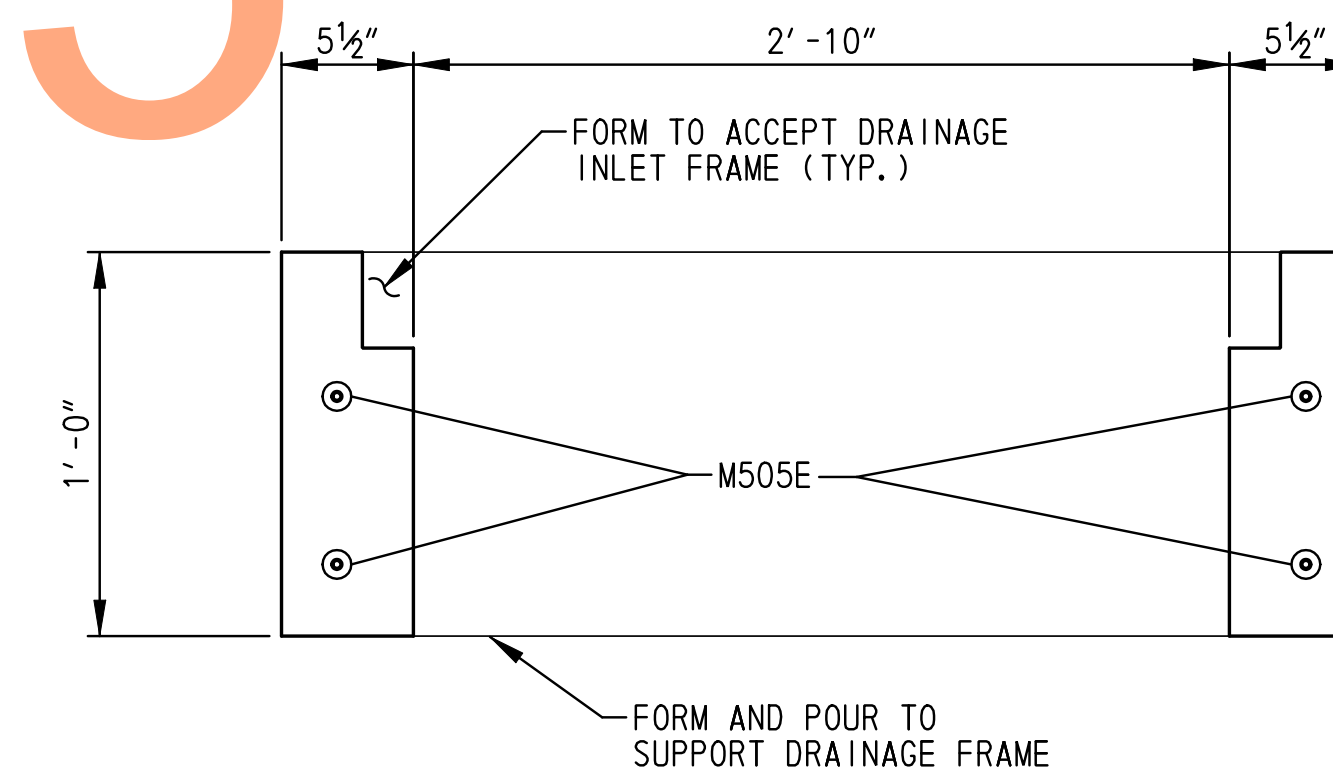

SECTION C-C
SCALE: 1 1/2" = 1' - 0"

ADDENDUMS / REVISIONS

SCALE: AS SHOWN

US 301 &
SR 1 INTERCHANGE

CONTRACT	BRIDGE NO.
T200911302	
COUNTY	DESIGNED BY: K.M.K.
NEW CASTLE	CHECKED BY: B.K.B.

CONSTRUCTION DETAILS

DT-11
SHEET NO.
94
TOTAL SHTS.
491

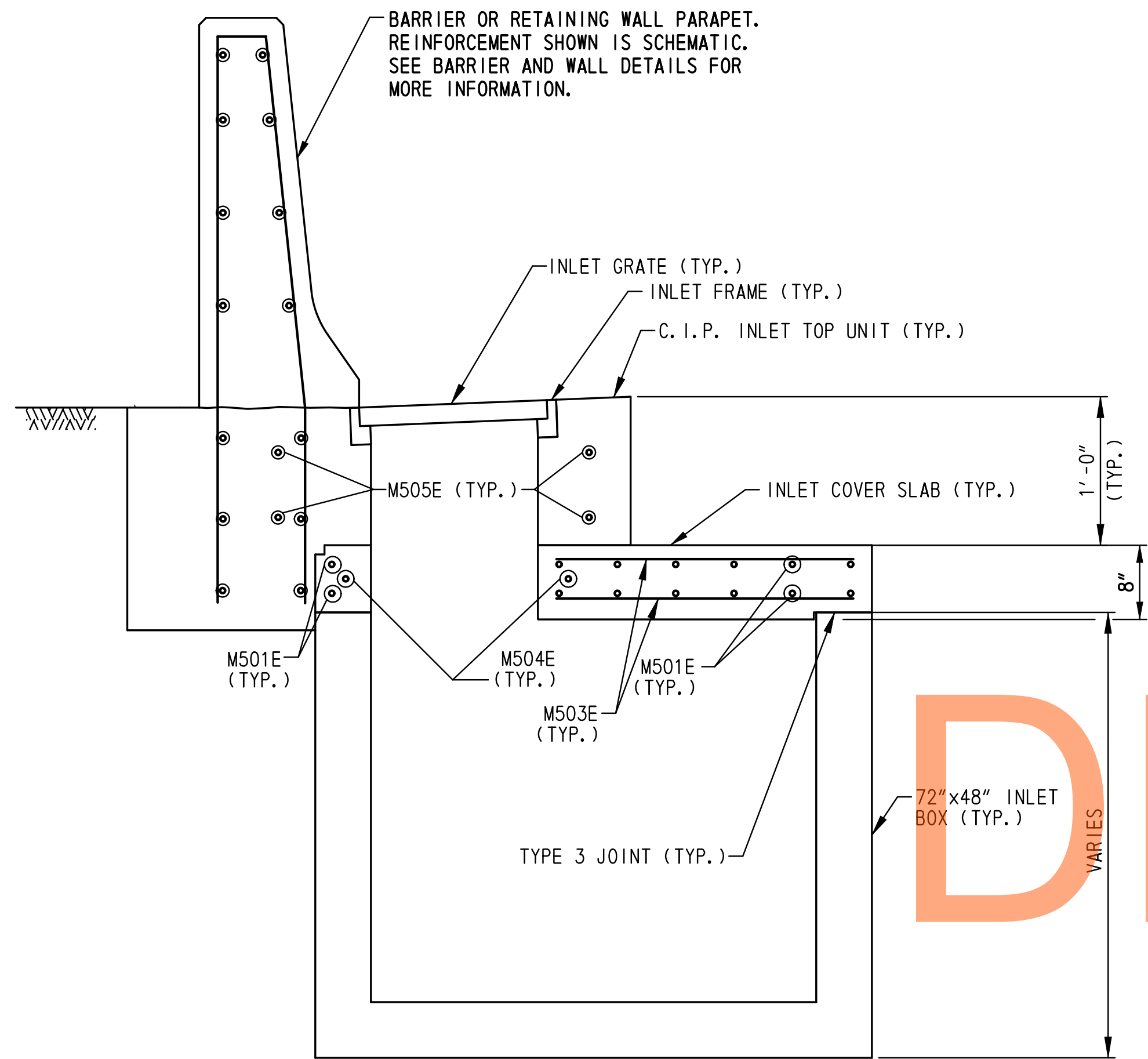

72" X 48" DRAINAGE INLET ASSEMBLY
SCALE: 1" = 1'-0"

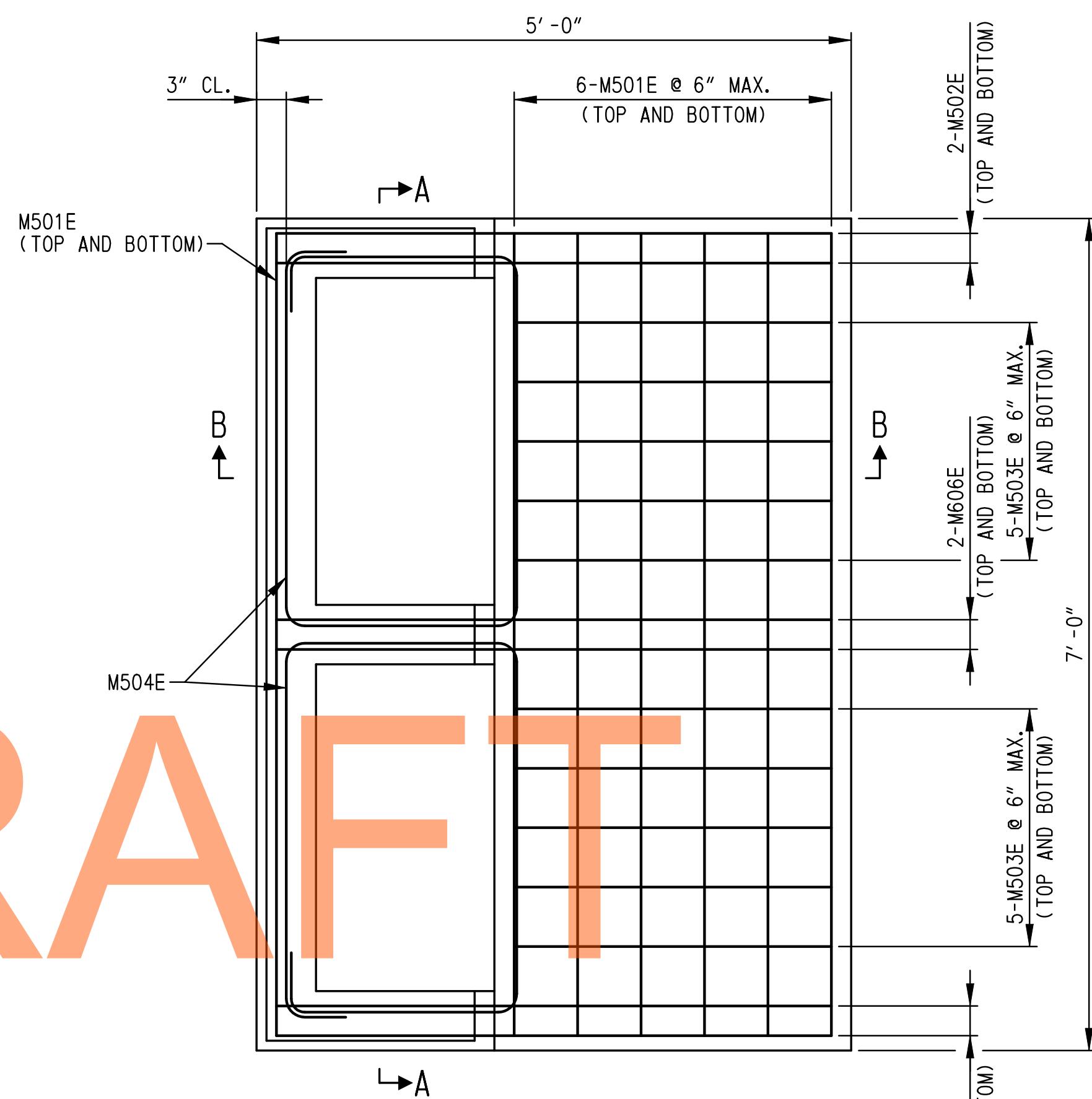

INLET COVER SLAB DETAIL
SCALE: 1" = 1'-0"

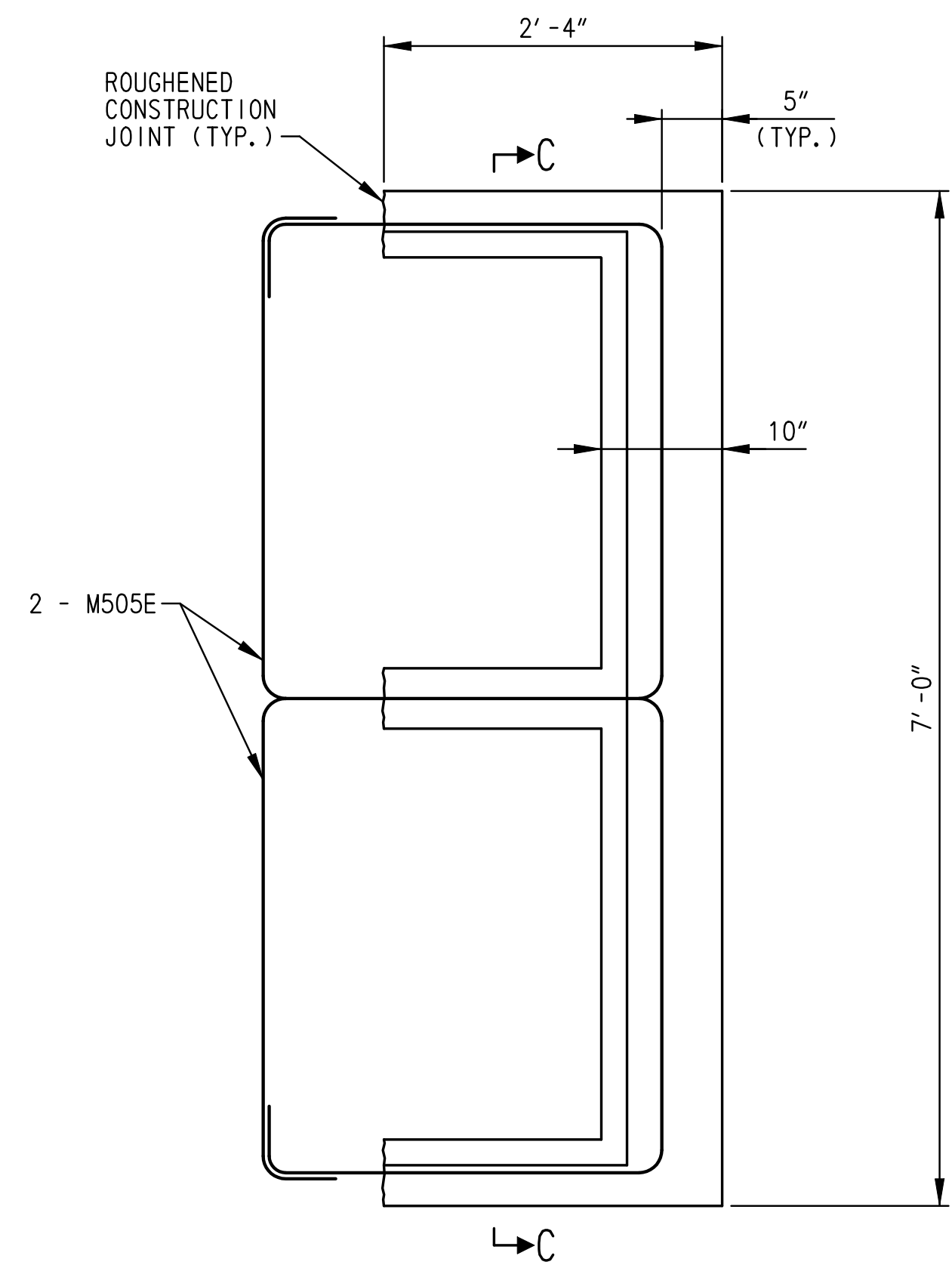

INLET TOP UNIT DETAIL
SCALE: 1" = 1'-0"

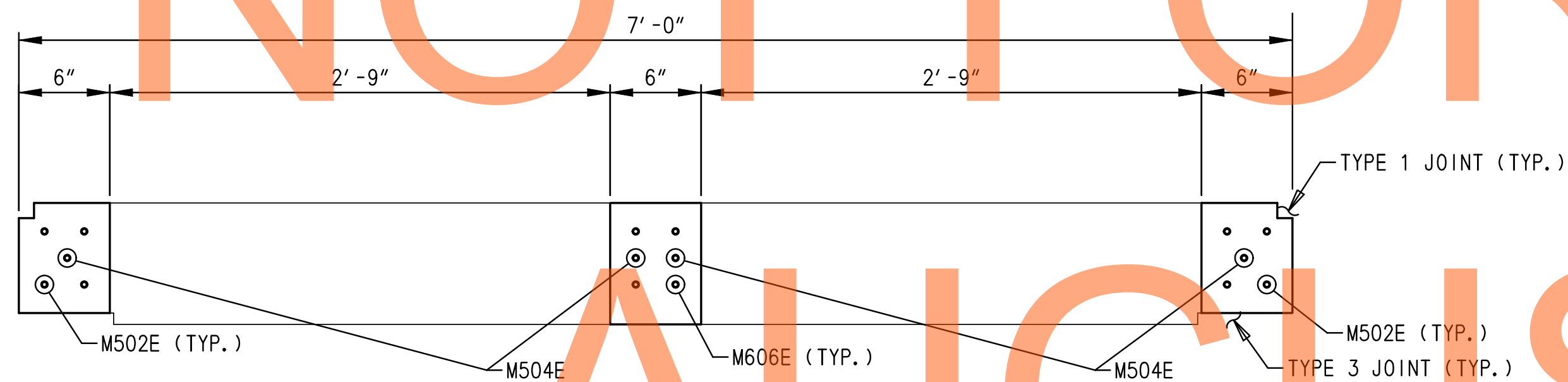

SECTION A-A
SCALE: 1 1/2" = 1'-0"

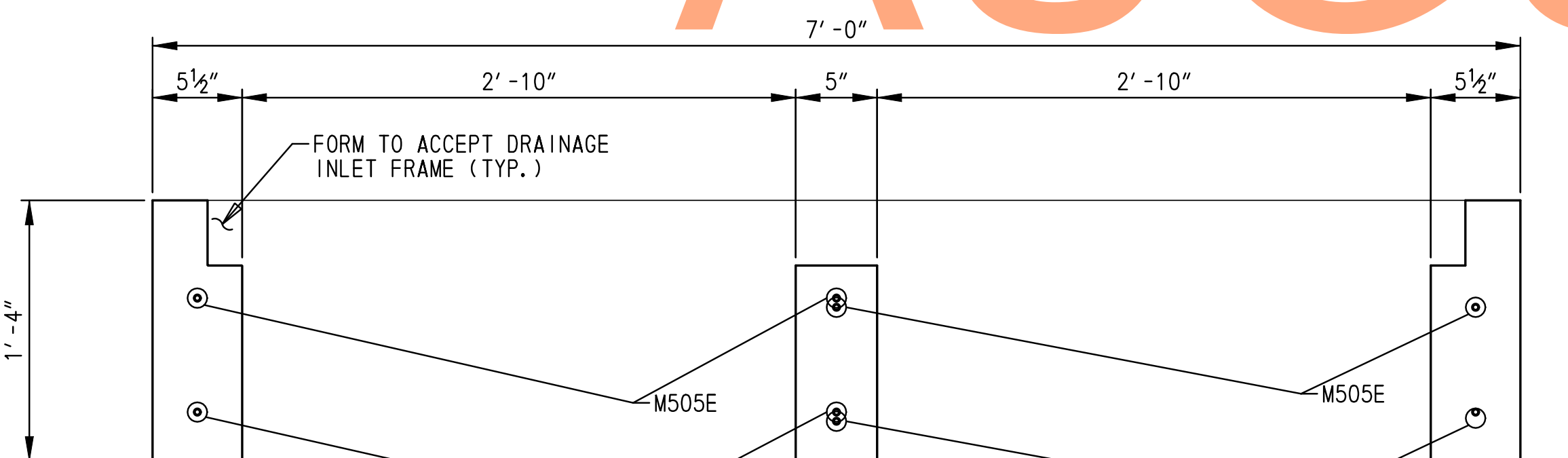

SECTION C-C
SCALE: 1 1/2" = 1'-0"

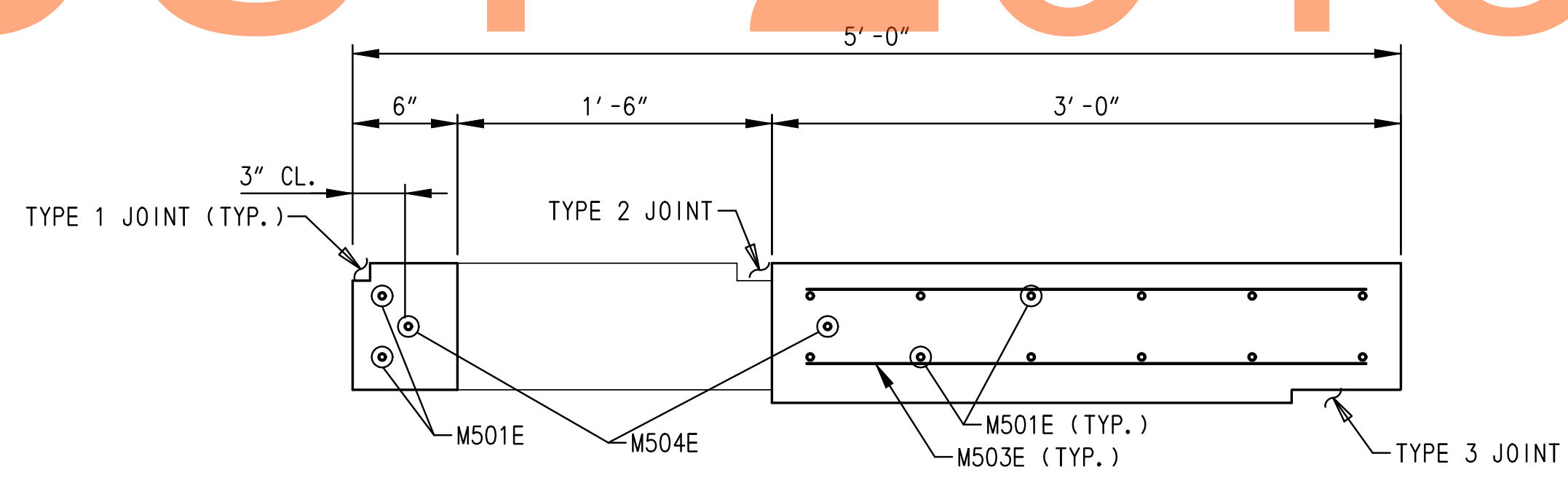

SECTION B-B
SCALE: 1 1/2" = 1'-0"

NOTES:

1. PAYMENT FOR DRAINAGE INLETS INCLUDING BOXES, GRATES, TOP UNITS, COVER SLABS, MODIFICATIONS TO CONCRETE MEDIAN BARRIER, JOINT SEALANT AND ALL WORK ASSOCIATED WITH DRAINAGE INLET ASSEMBLIES WILL BE MADE UNDER ITEM NO. 708058 - DRAINAGE INLET, 72" X 48".
2. FOR DRAINAGE INLET ASSEMBLY LOCATIONS SEE CONSTRUCTION PLANS.
3. SEE STANDARD NO. D-4 FOR INLET BOX DETAILS. SEE STANDARD NO. D-5 FOR GRATE, FRAME, AND JOINT DETAILS.
4. MINIMUM REINFORCEMENT COVER SHALL BE 1 1/2".
5. HOT POURED JOINT SEALANT SHALL BE USED TO FILL THE GAP BETWEEN THE DRAINAGE INLET FRAMES.

DRAFT

NOT FOR BIDDING

AUGUST 2015

P:\31653-000\contract\p\cead\DT02U301_B.dgn 5/17/2015 14:25:25 AM

ADDENDUMS / REVISIONS	

CONTRACT T200911302	BRIDGE NO.
COUNTY NEW CASTLE	DESIGNED BY: W.T.R.
	CHECKED BY: J.A.G.

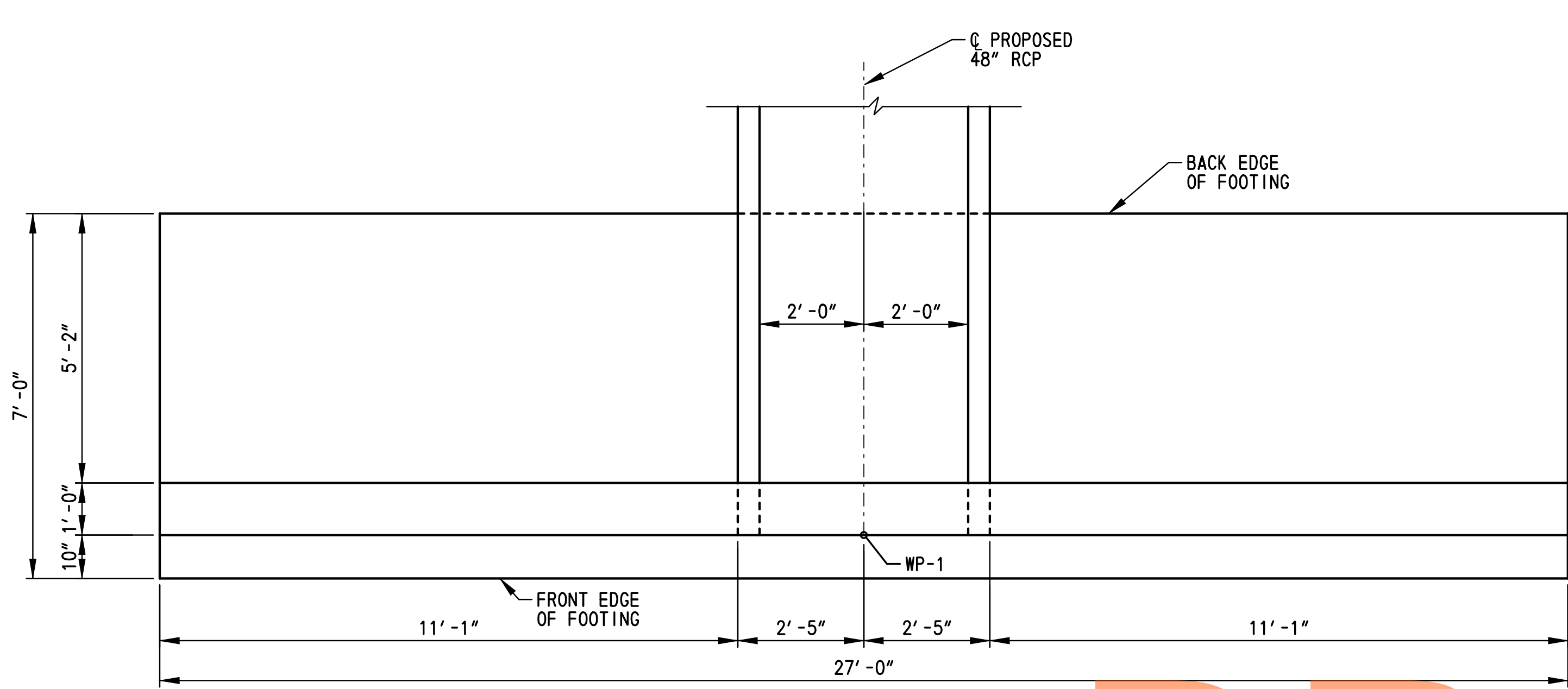

ENDWALL NO. 401 - NO. 403 - PLAN
SCALE: 1/2"=1'-0"

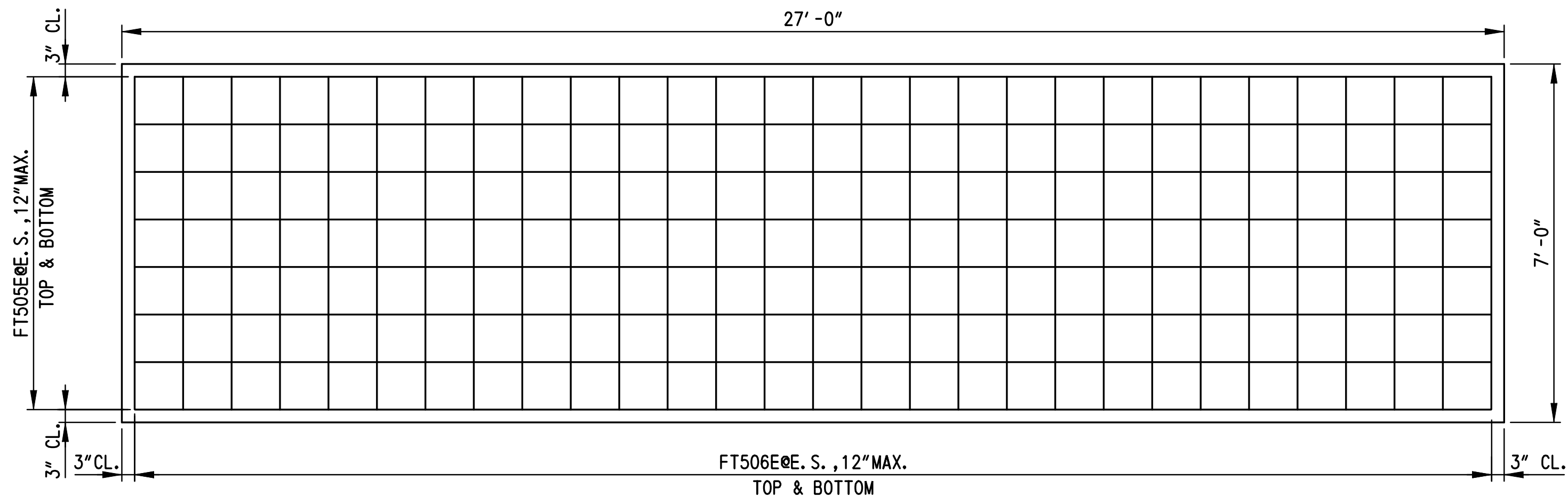

ENDWALL NO. 401 - NO. 403 - FOOTING REINFORCEMENT PLAN
SCALE: 1/2"=1'-0"

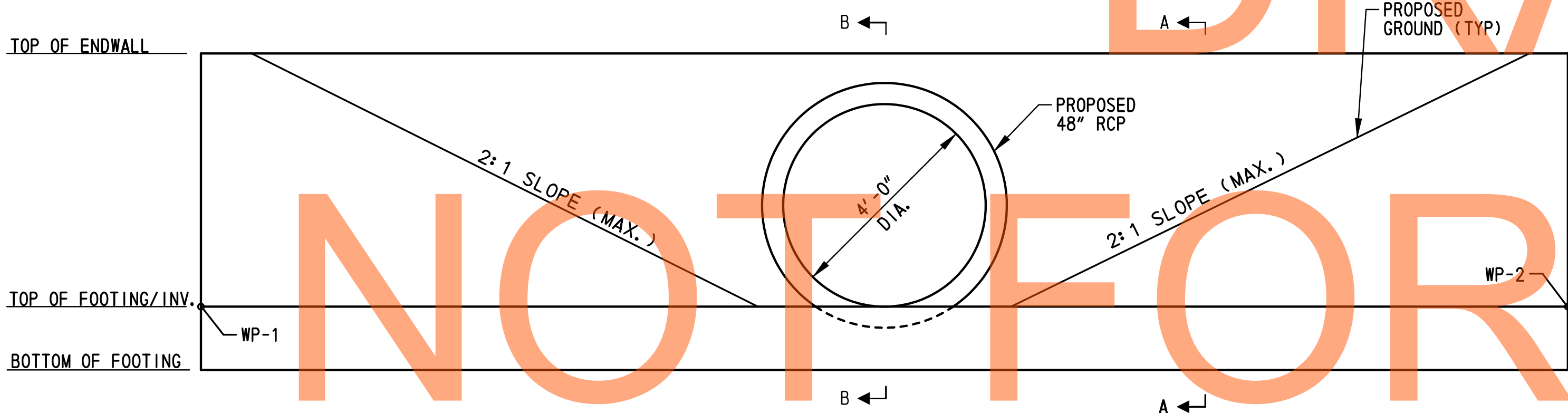

ENDWALL NO. 401 - NO. 403 - ELEVATION
SCALE: 1/2"=1'-0"

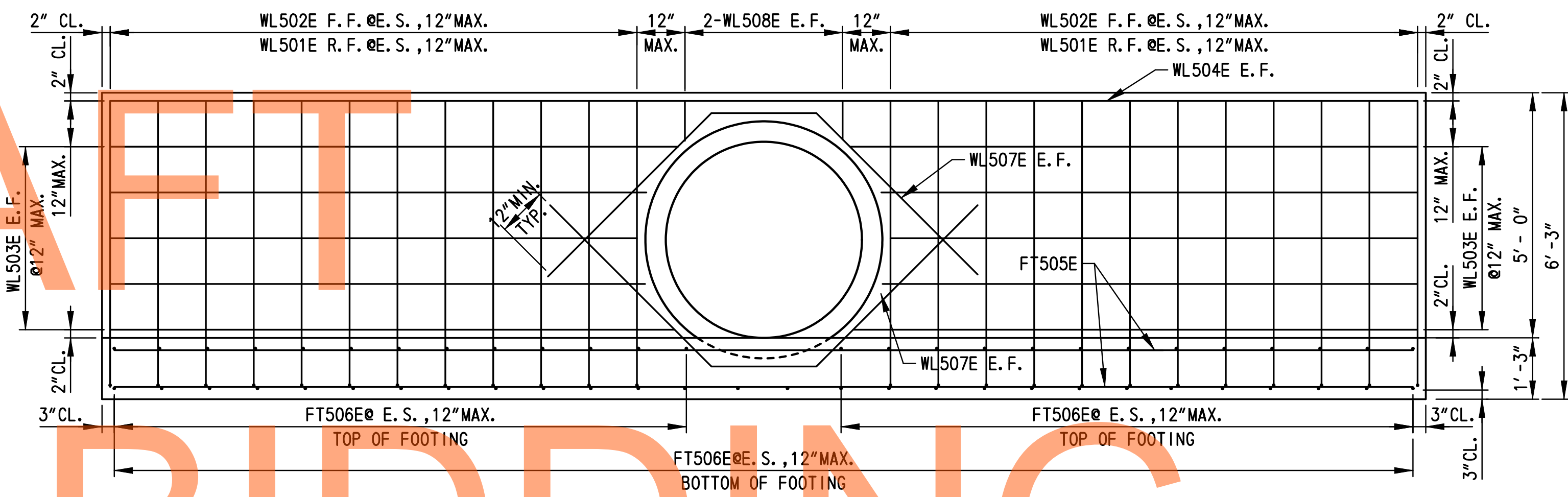

ENDWALL NO. 401 - NO. 403 - REINFORCEMENT ELEVATION
SCALE: 1/2"=1'-0"

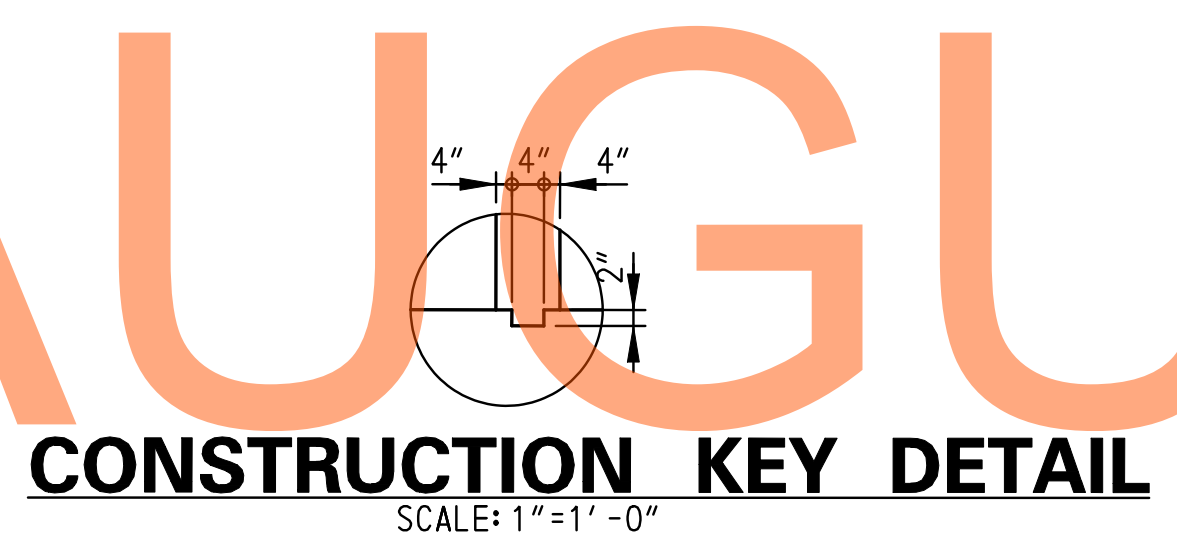

CONSTRUCTION KEY DETAIL
SCALE: 1"=1'-0"

ENDWALL NO. 401 - NO. 403 NOTES:

1. MAXIMUM FACTORED BEARING RESISTANCE FOR THE ENDWALL IS 2 KSF.
2. KEYS ARE NOMINAL SIZE.
3. CONCRETE SHALL BE CLASS A, 4500 PSI.
4. REBAR REINFORCEMENT SHALL BE DEFORMED BARS AS SHOWN AND SHALL CONFORM TO ASTM A 615, GRADE 60.
5. RIPRAP IN FRONT OF WALL NOT SHOWN FOR CLARITY.
6. ENDWALL NO. 401 TO NO. 404 SHALL BE CAST-IN-PLACE. NO PRECAST ALTERNATIVE WILL BE ALLOWED.
7. E. F. = EACH FACE
F. F. = FRONT FACE
R. F. = RARE FACE
E. S. = EQUAL SPACING.
8. SEE REINFORCING BAR LIST ON DRAWING DT-15.
9. THE COST OF THE GRADED AGGREGATE BEDDING SHALL BE INCIDENTAL TO THE CONTRACT UNIT COST FOR THE ENDWALL (ITEM 617515).

WORKING POINT LOCATION			
ENDWALL NO.	WP	NORTHING	EASTING
EW/401	WP-1	556572.58	590061.73
	WP-2	556564.56	590087.37
EW/402	WP-1	557030.50	590196.92
	WP-2	557047.57	590176.00
EW/403	WP-1	557551.25	590274.69
	WP-2	557576.86	590283.25

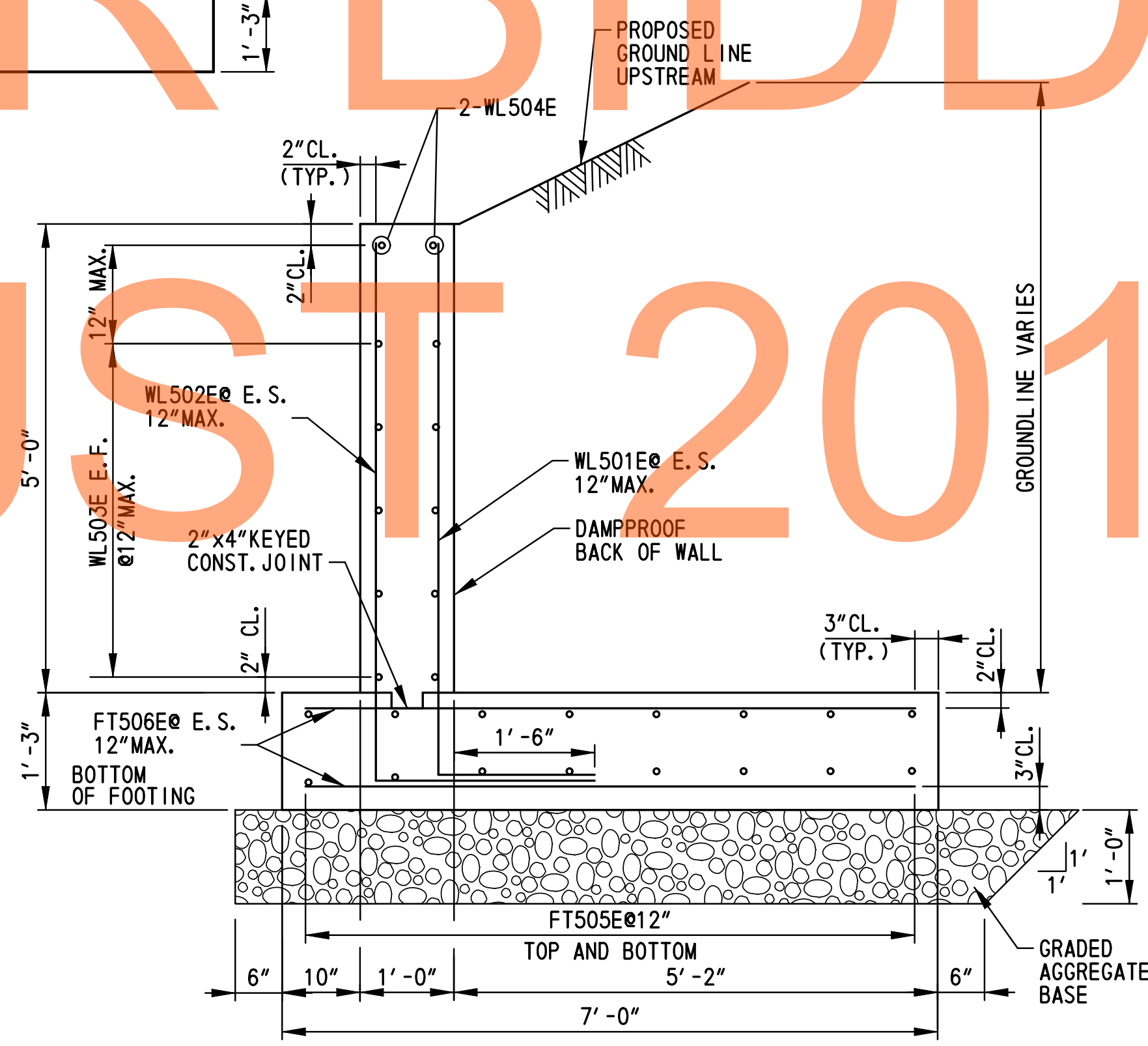

SECTION A-A
SCALE: 3/4"=1'-0"

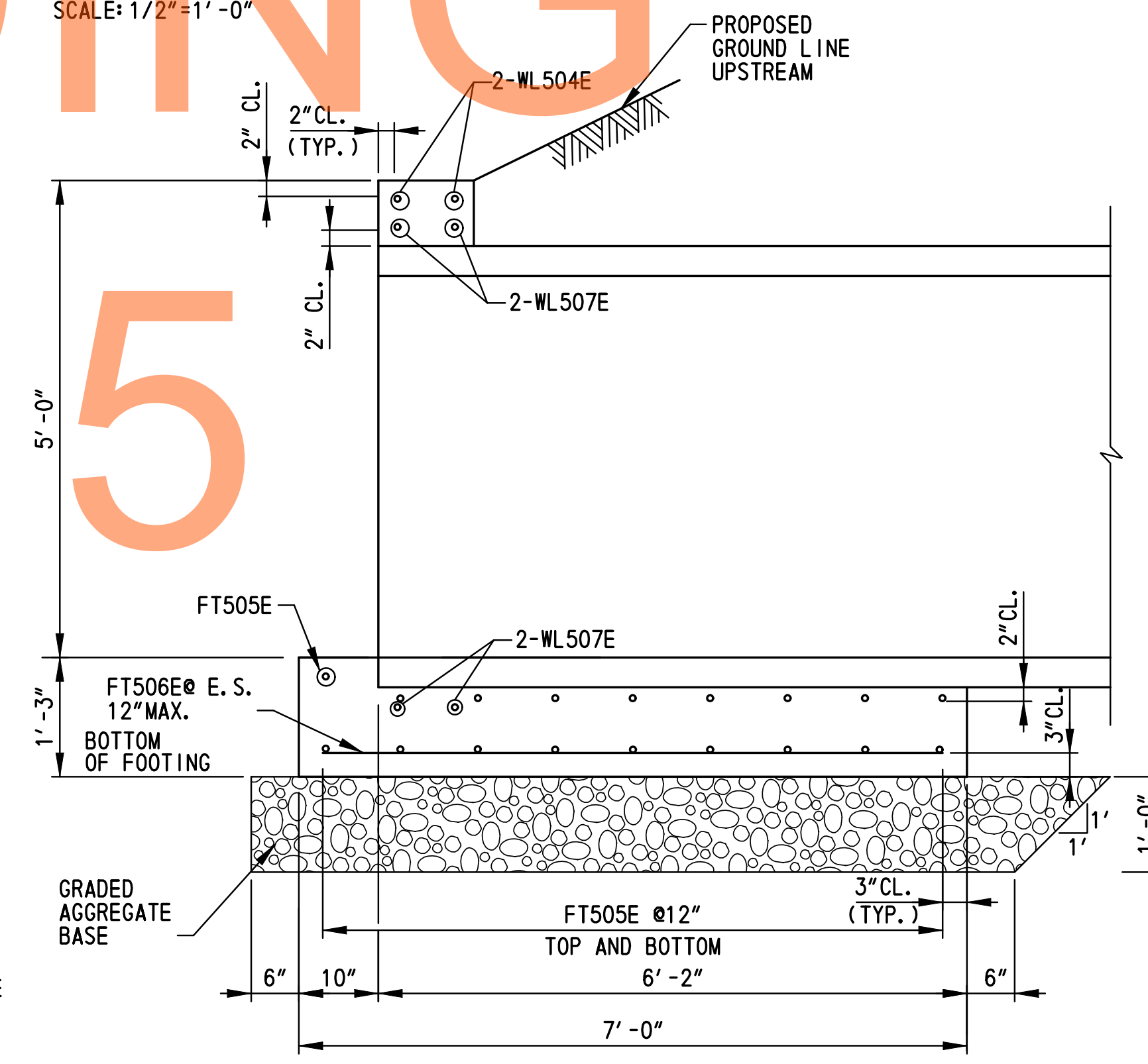

SECTION B-B
SCALE: 3/4"=1'-0"

P:\31653-000\CONTRACT\B\CADD\DT03U301-1B.dgn
 5/21/2015 12:42:05 AM

<p>DELAWARE DEPARTMENT OF TRANSPORTATION</p>	ADDENDUMS / REVISIONS	<p>SCALE: AS SHOWN</p>	<p>US 301 & SR 1 INTERCHANGE</p>	CONTRACT	BRIDGE NO.	<p>CONSTRUCTION DETAILS</p>	SHEET NO.
	T200911302				DESIGNED BY: HQ		96
	NEW CASTLE				CHECKED BY: JW		TOTAL SHTS.
						491	

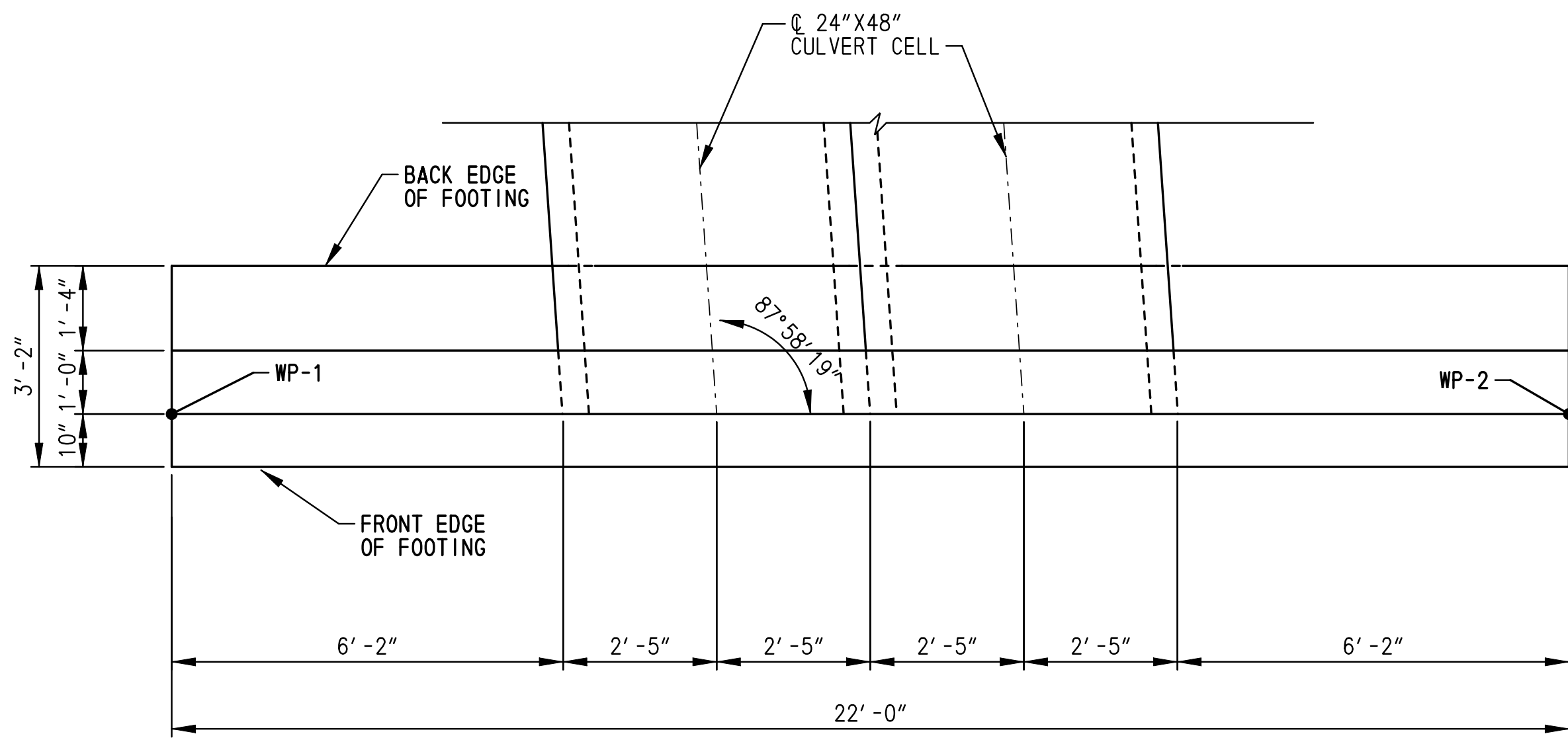

ENDWALL NO. 201 - NO. 206 - PLAN
SCALE: 1/2" = 1' - 0"

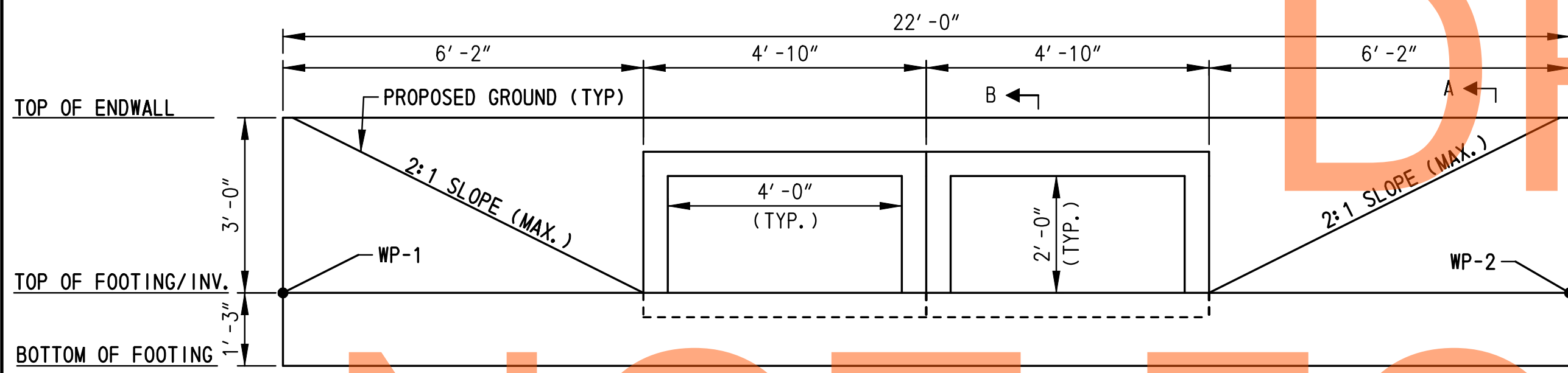

ENDWALL NO. 201 - NO. 206 - ELEVATION
SCALE: 1/2" = 1' - 0"

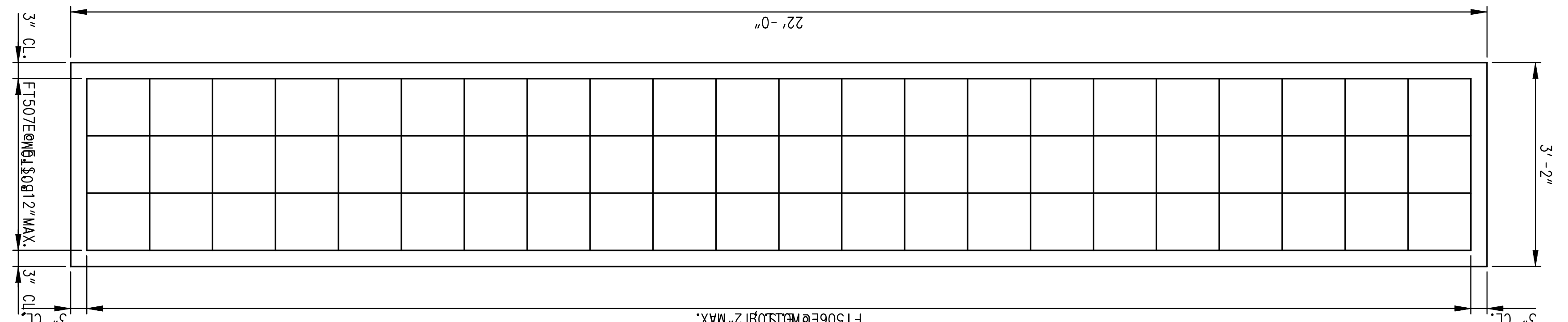

ENDWALL NO. 201 - NO. 206 - FOOTING REINFORCEMENT PLAN
SCALE: 3/4" = 1' - 0"

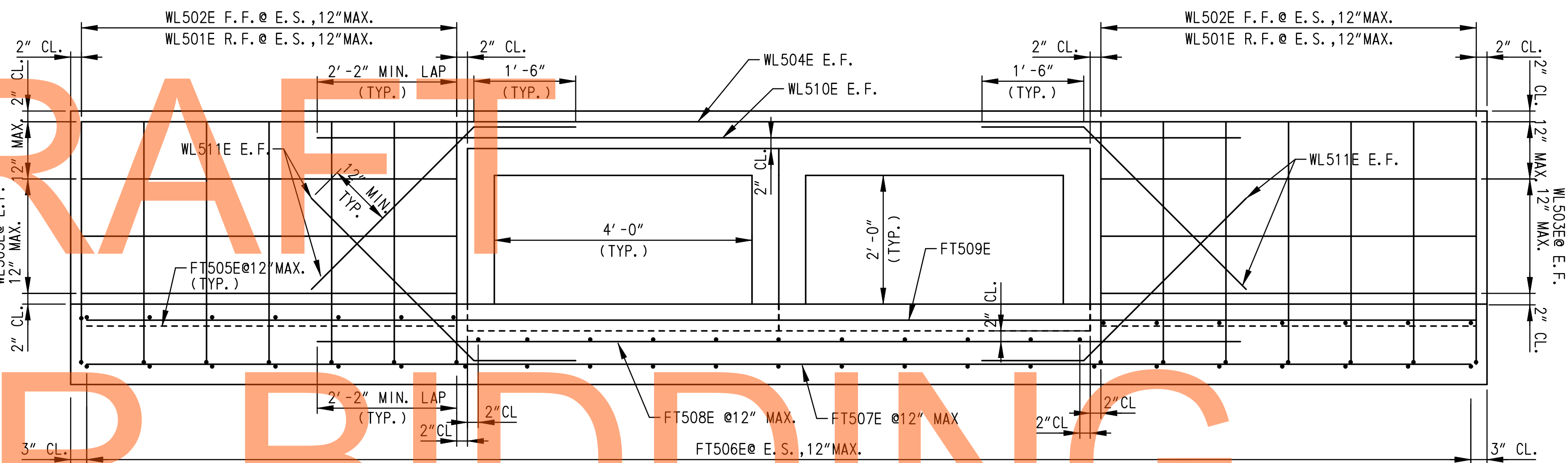

ENDWALL NO. 201 - NO. 206 - REINFORCEMENT ELEVATION
SCALE: 3/4" = 1' - 0"

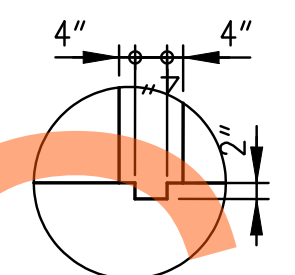

CONSTRUCTION KEY DETAIL
SCALE: 1" = 1' - 0"

ENDWALL NO. 201 - NO. 206 NOTES:

1. MAXIMUM FACTORED BEARING RESISTANCE FOR THE ENDWALL IS 2 KSF.
2. KEYS ARE NOMINAL SIZE.
3. CONCRETE SHALL BE CLASS A, 4500 PSI.
4. RIPRAP IN FRONT OF WALL NOT SHOWN FOR CLARITY.
5. ENDWALL NO. 203 SHALL BE CAST-IN-PLACE. NO PRECAST ALTERNATIVE WILL BE ALLOWED.
6. E. F. = EACH FACE
F. F. = FRONT FACE
R. F. = RARE FACE
E. S. = EQUAL SPACING.
7. SEE REINFORCING BAR LIST ON DRAWING DT-09.
8. THE COST OF THE GRADED AGGREGATE BEDDING SHALL BE INCIDENTAL TO THE CONTRACT UNIT COST FOR THE ENDWALL (ITEM 617515).

WORKING POINT LOCATION			
ENDWALL NO.	WP	NORTHING	EASTING
EW/404	WP-1	557817.39	590258.48
	WP-2	557788.98	590252.66

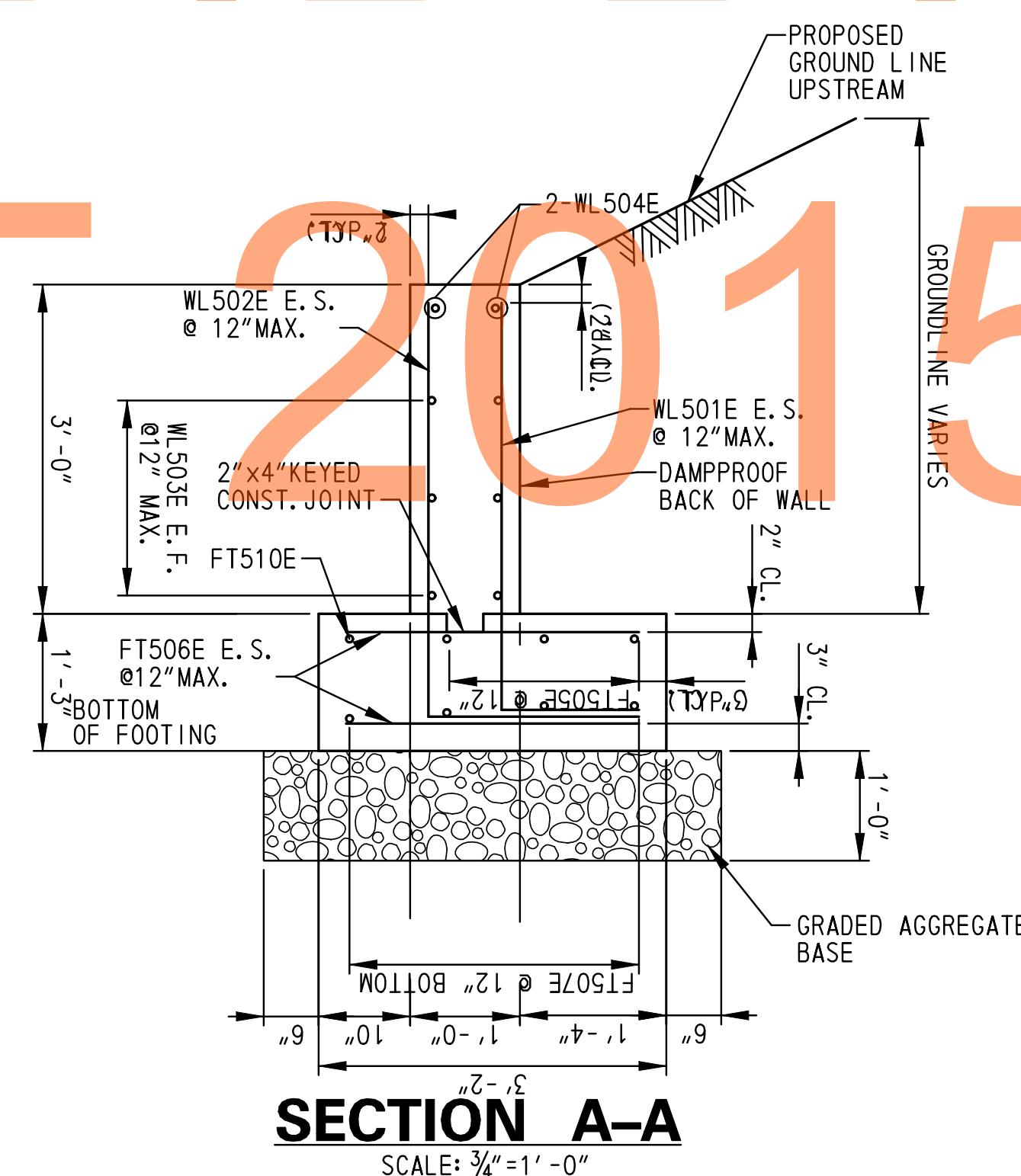

SECTION A-A
SCALE: 3/4" = 1' - 0"

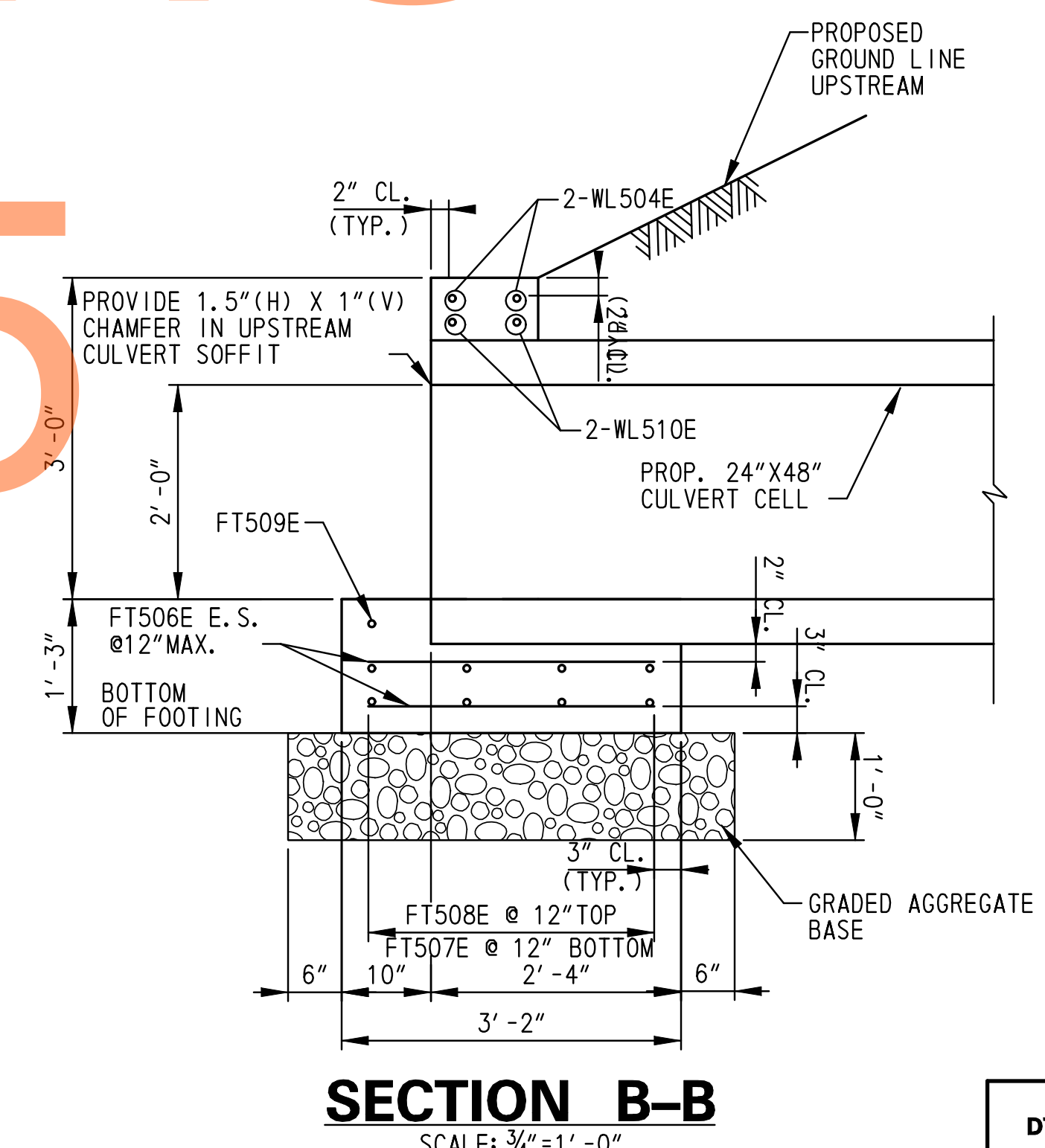

SECTION B-B
SCALE: 3/4" = 1' - 0"

P:\31653-000\contract\lb\cadd\DT014U30.LB.dgn 5/21/2015 1:42:56 AM

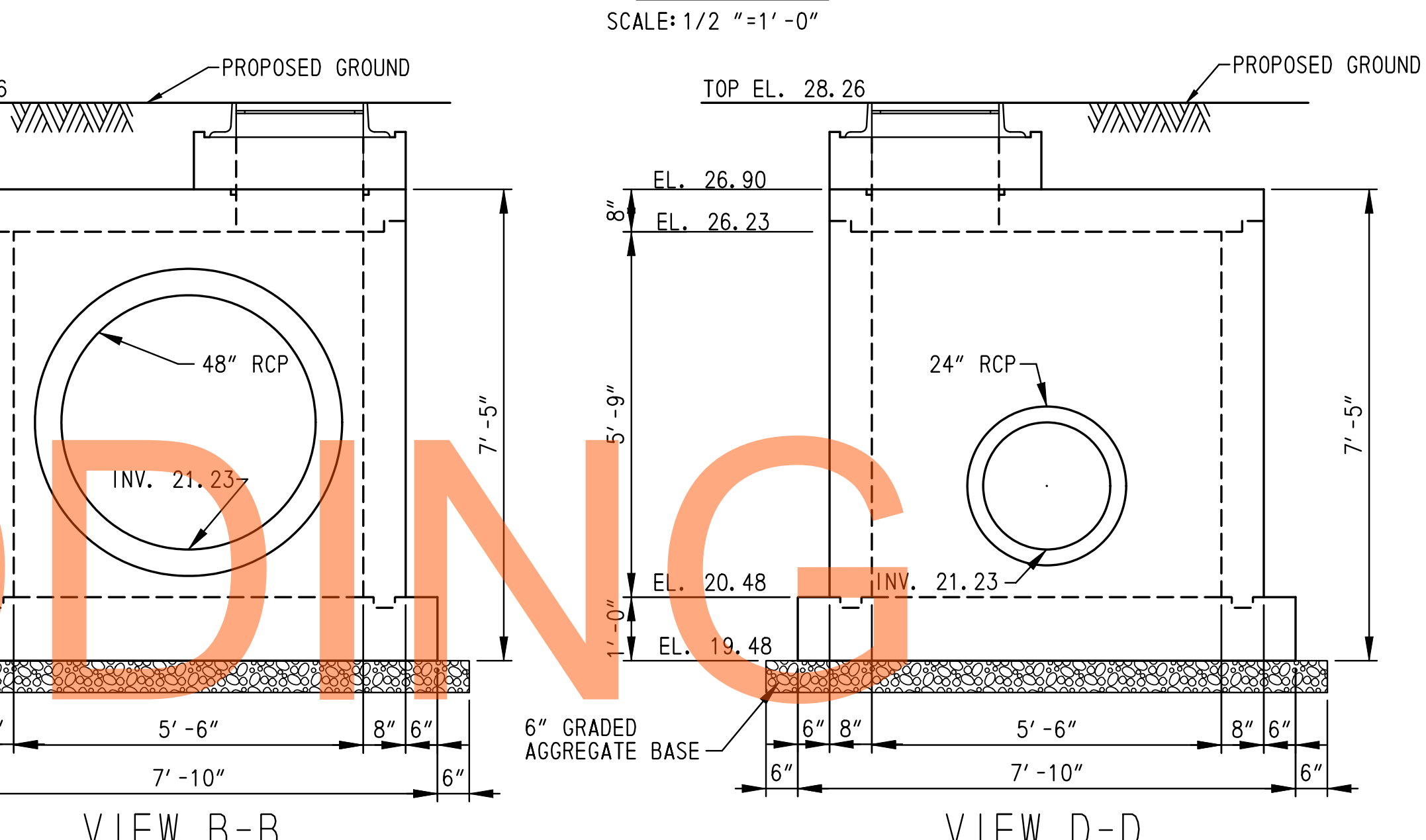
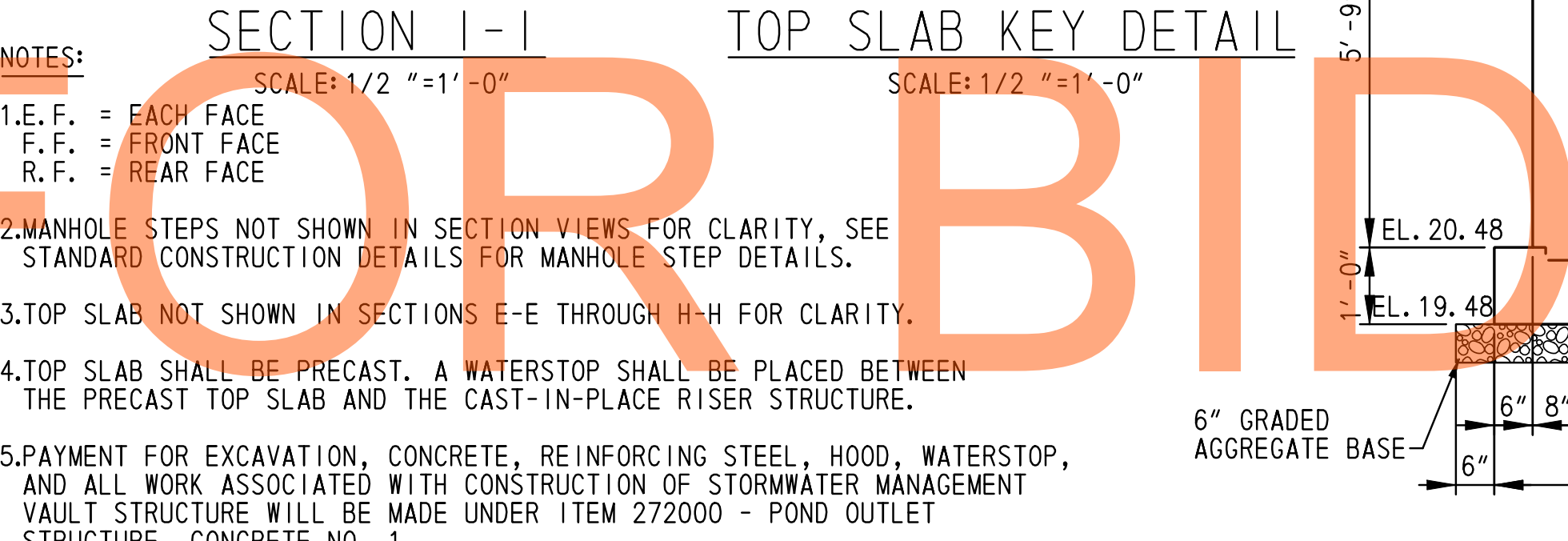
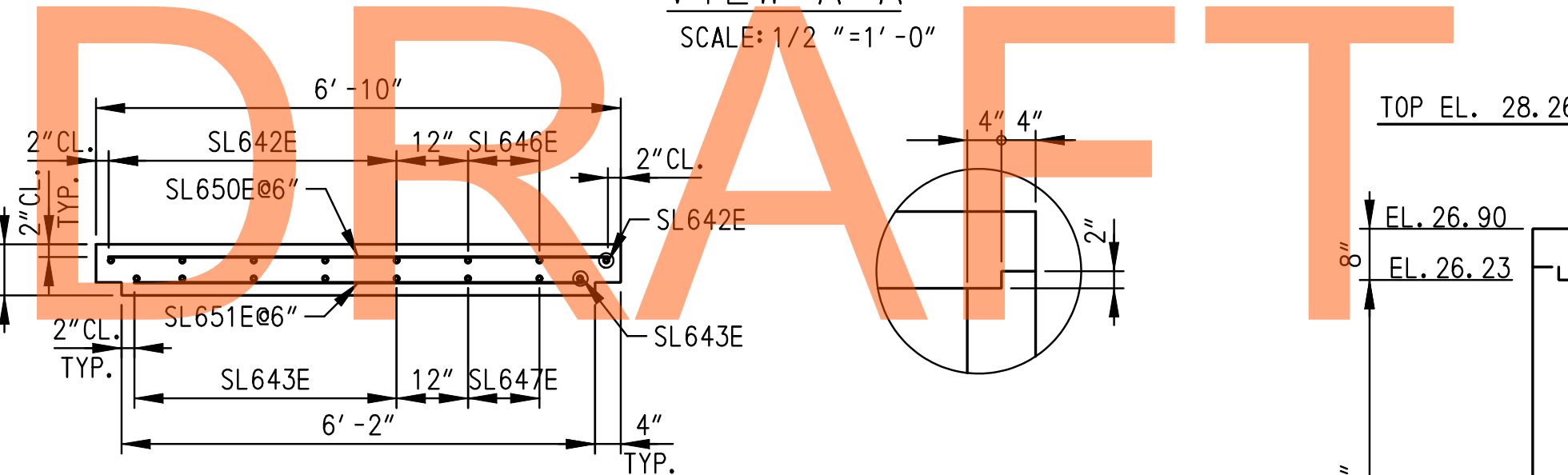
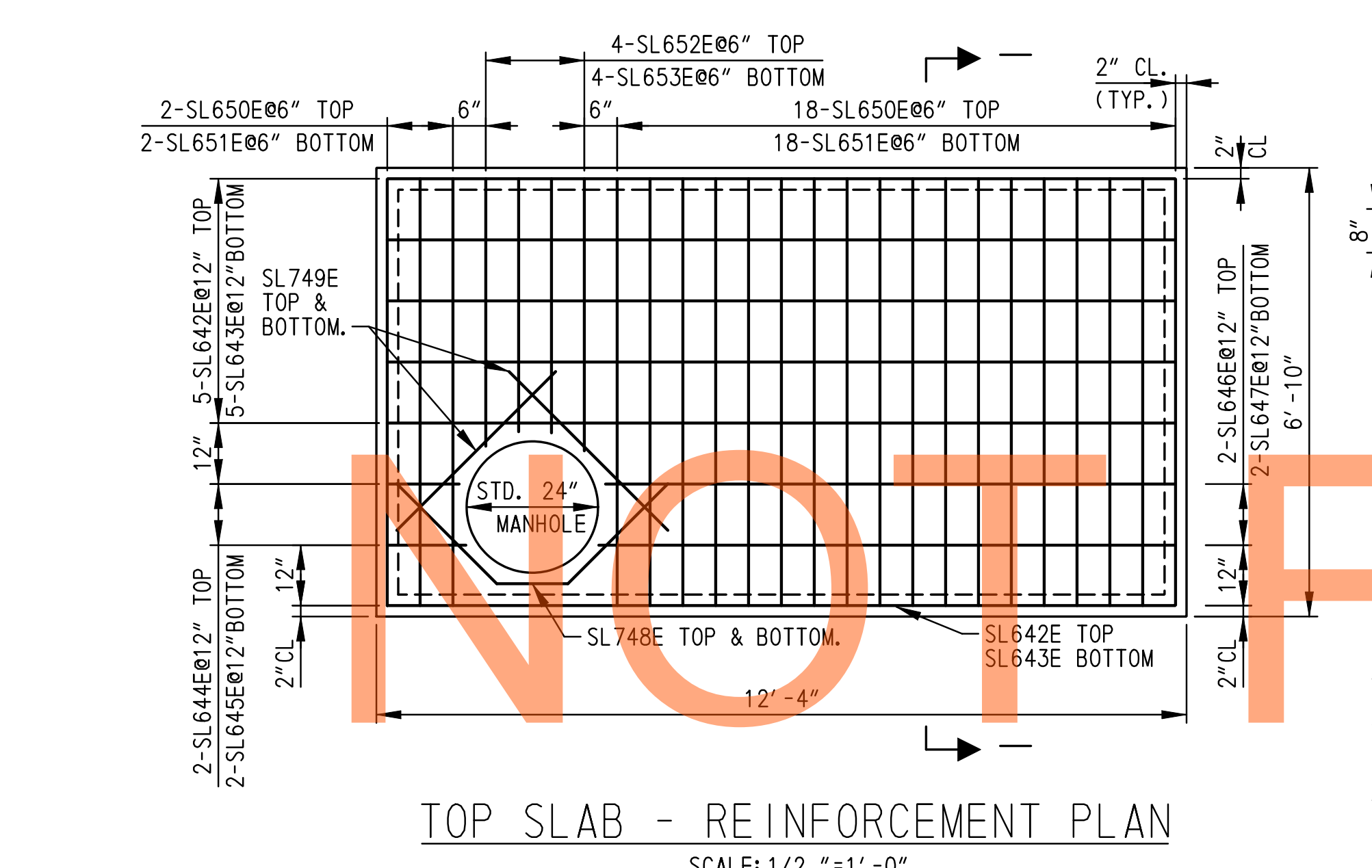
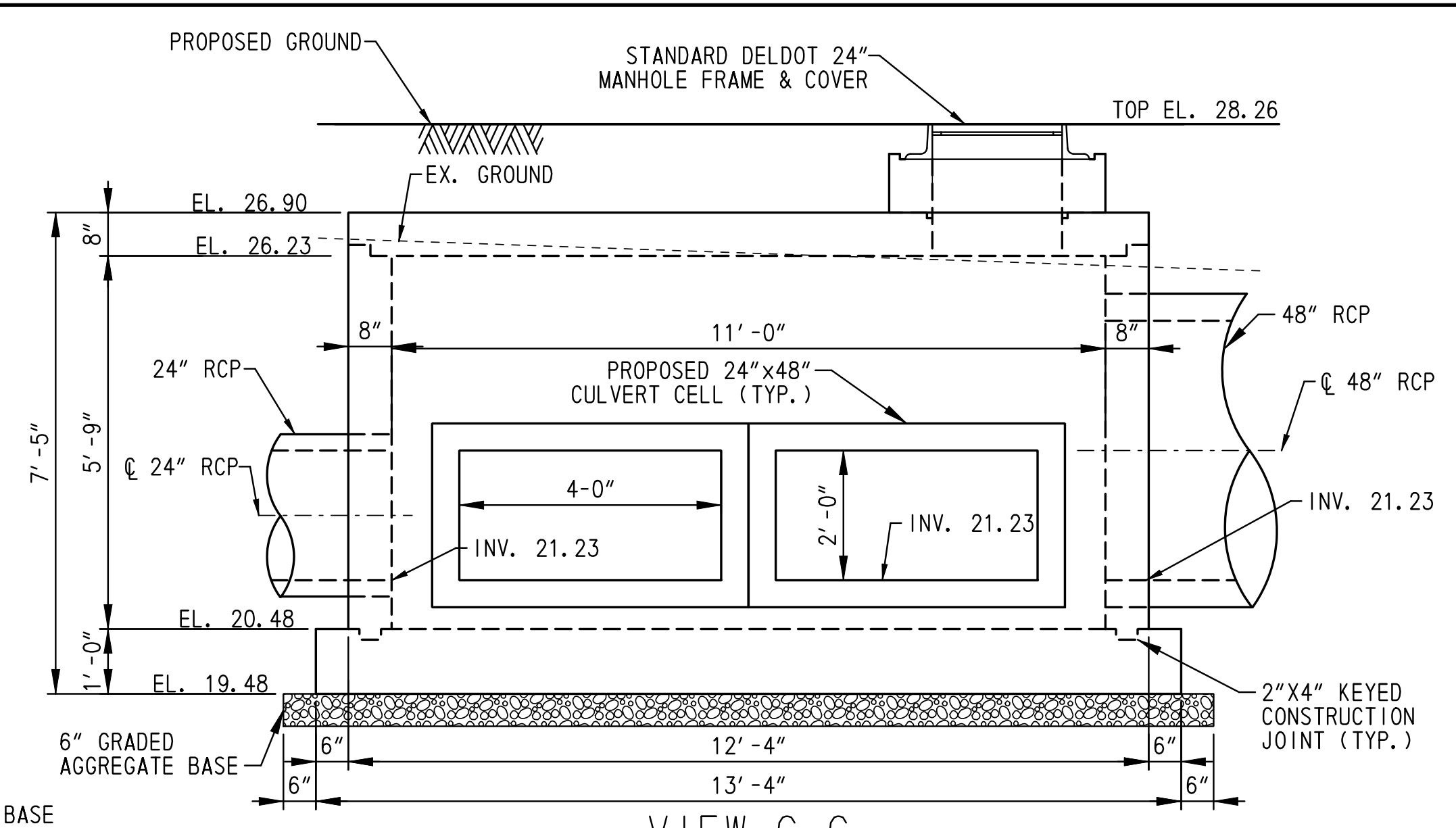
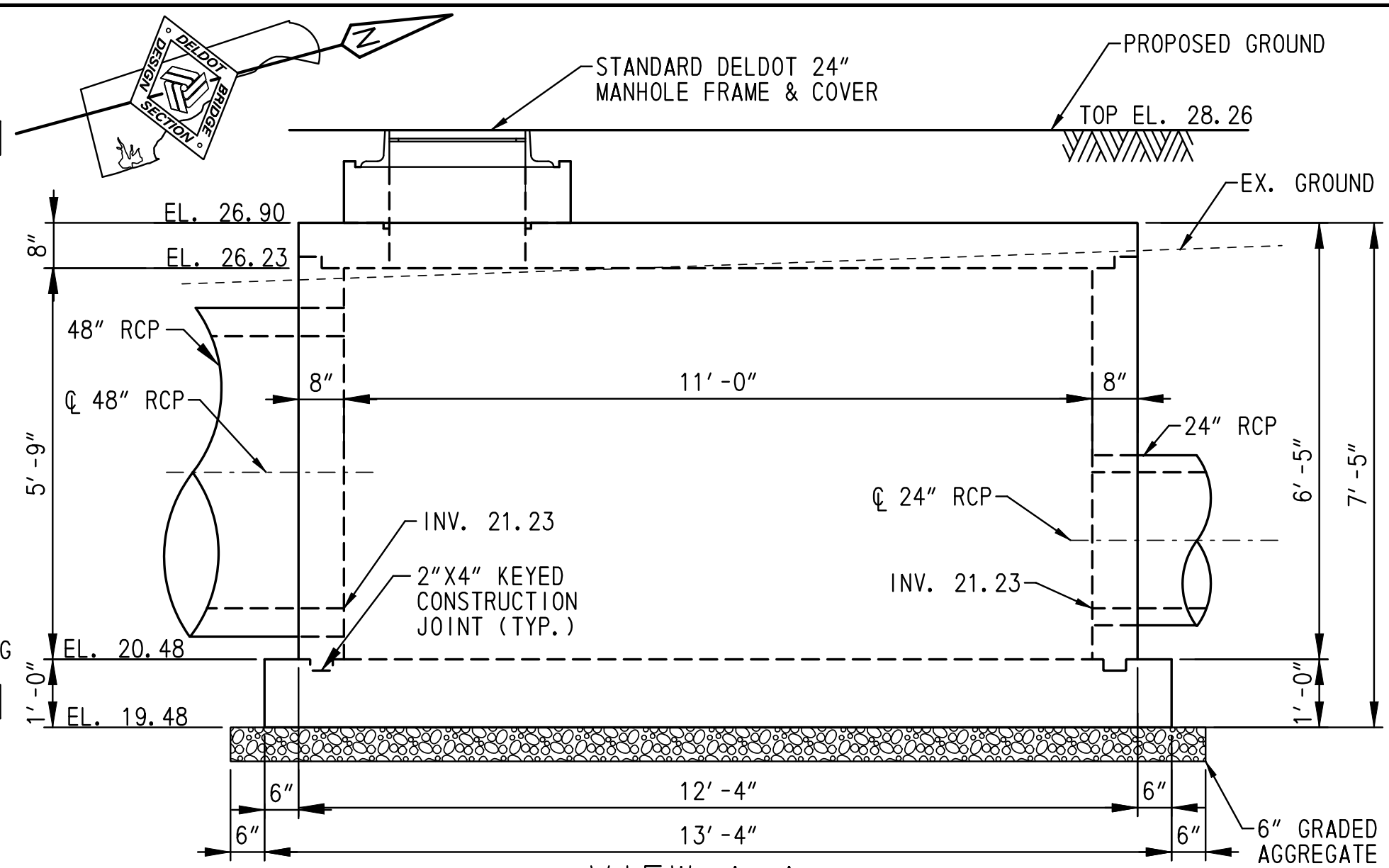
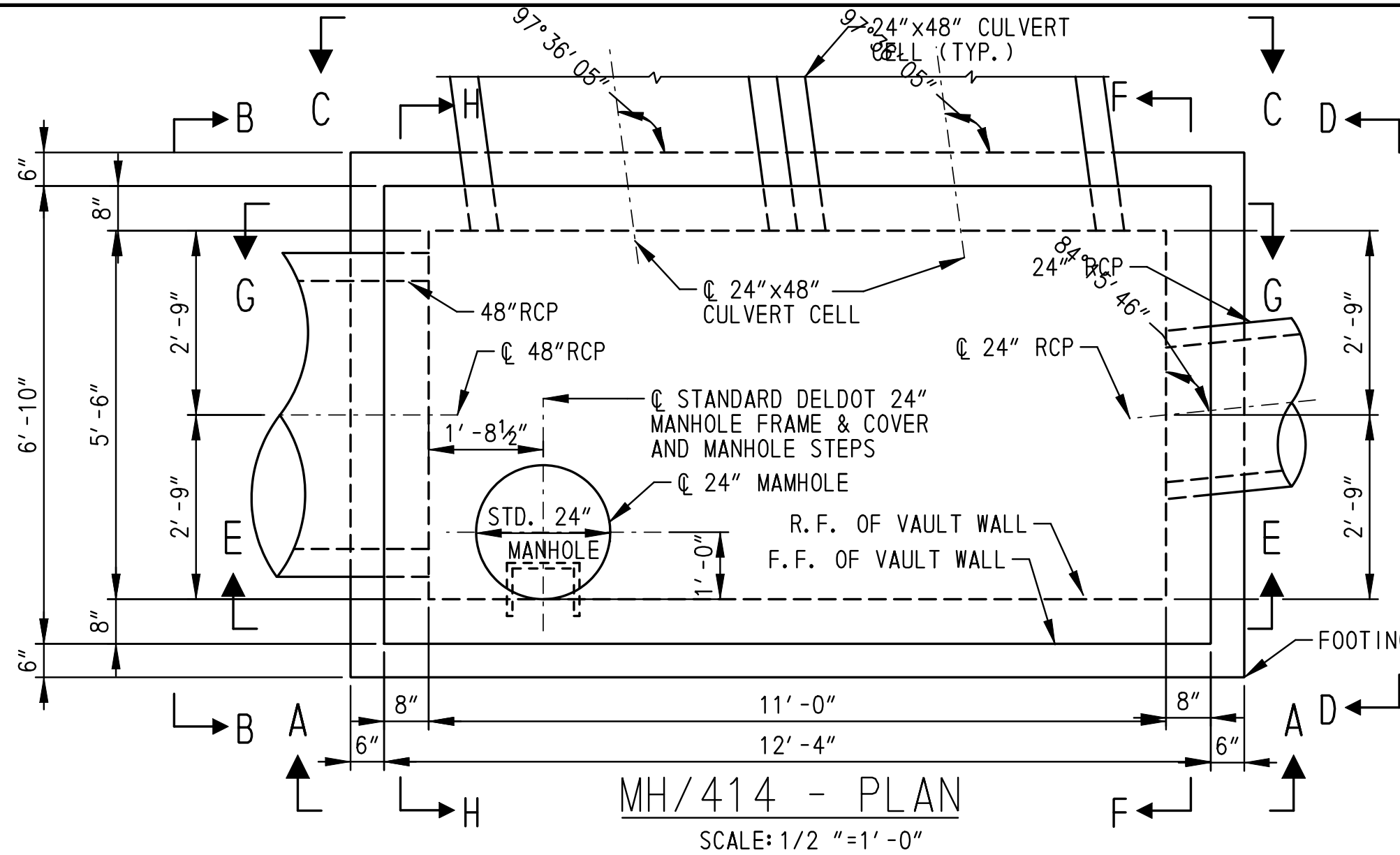

- NOTES:**
- E.F. = EACH FACE
F.F. = FRONT FACE
R.F. = REAR FACE
 - MANHOLE STEPS NOT SHOWN IN SECTION VIEWS FOR CLARITY, SEE STANDARD CONSTRUCTION DETAILS FOR MANHOLE STEP DETAILS.
 - TOP SLAB NOT SHOWN IN SECTIONS E-E THROUGH H-H FOR CLARITY.
 - TOP SLAB SHALL BE PRECAST. A WATERSTOP SHALL BE PLACED BETWEEN THE PRECAST TOP SLAB AND THE CAST-IN-PLACE RISER STRUCTURE.
 - PAYMENT FOR EXCAVATION, CONCRETE, REINFORCING STEEL, HOOD, WATERSTOP, AND ALL WORK ASSOCIATED WITH CONSTRUCTION OF STORMWATER MANAGEMENT VAULT STRUCTURE WILL BE MADE UNDER ITEM 272000 - POND OUTLET STRUCTURE, CONCRETE NO. 1.
 - THE COST OF THE GRADED AGGREGATE BEDDING SHALL BE INCIDENTAL TO THE CONTRACT UNIT COST FOR THE ENDWALL (ITEM 617515).

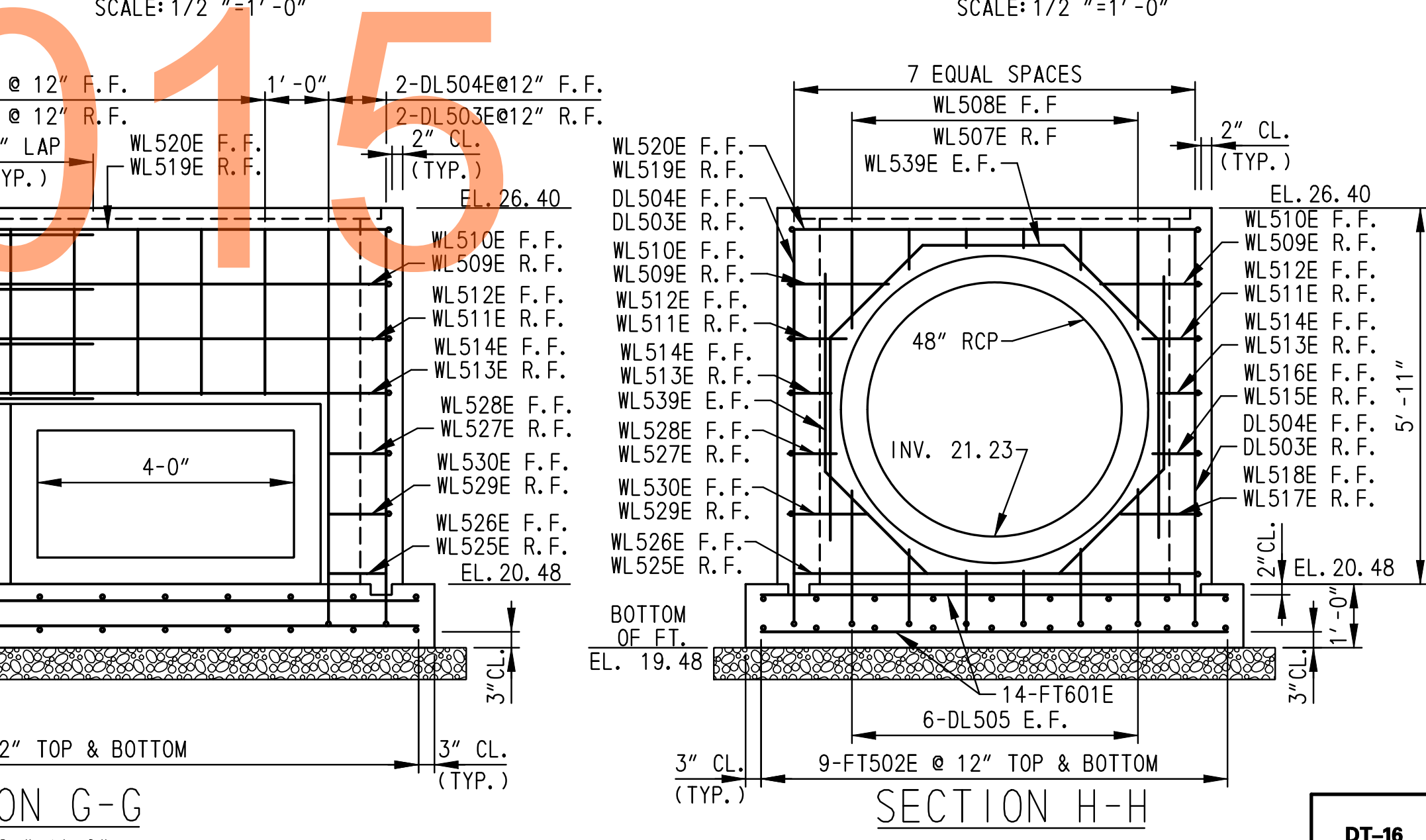
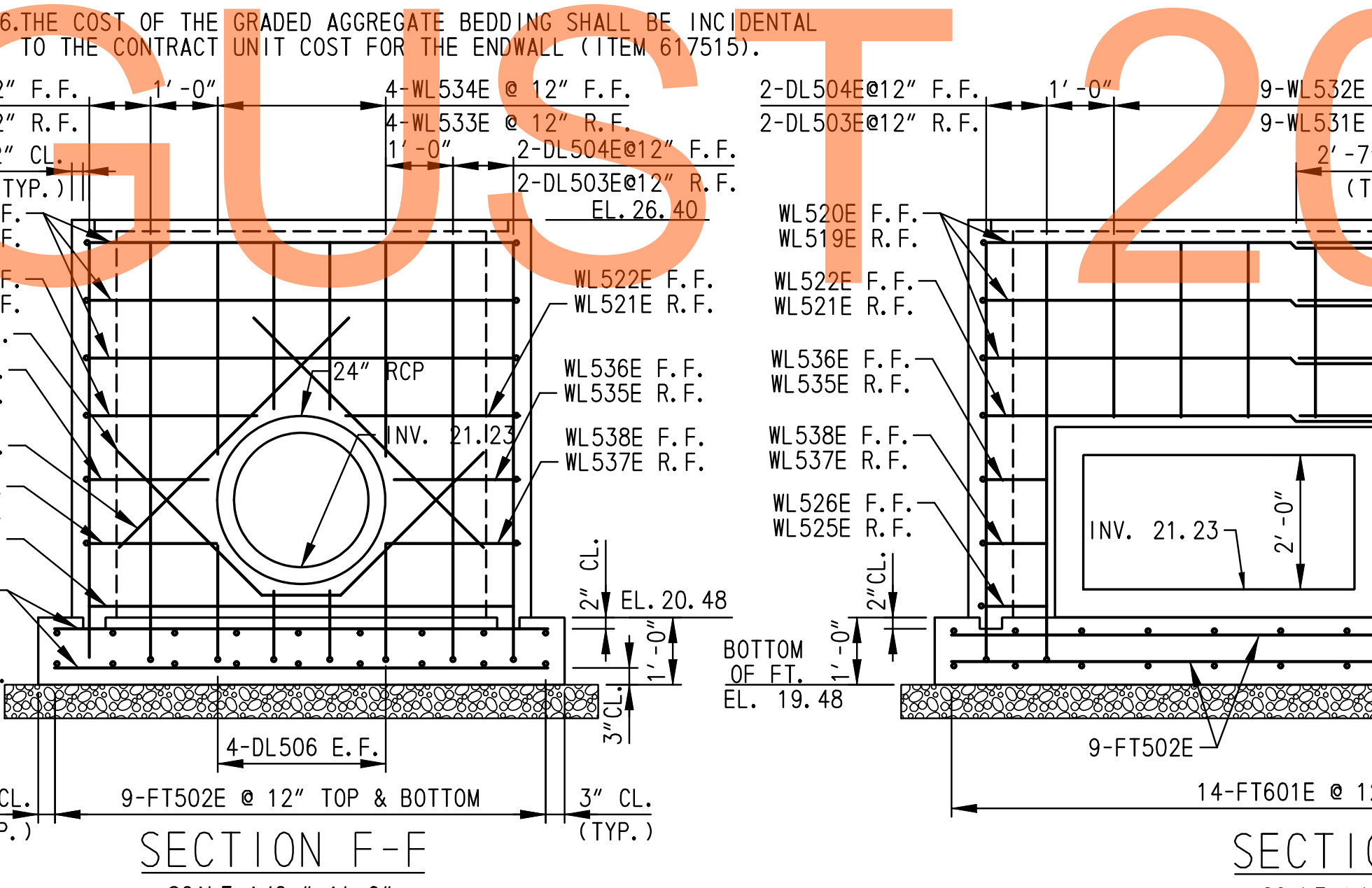
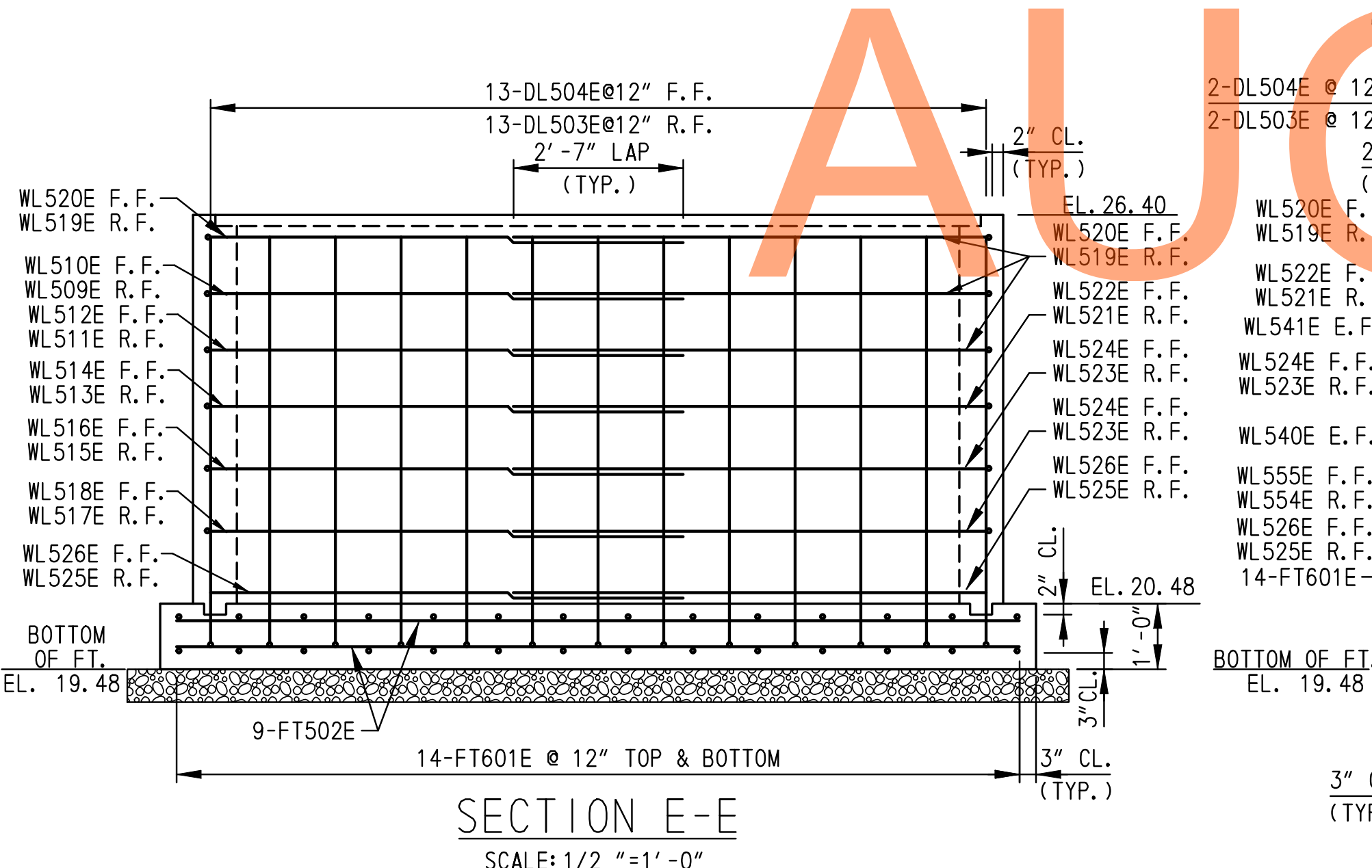

P:\31653-000\contract\lb\cead\DT016U301.LB.dgn
 5/17/2015 1:42:42 AM

ADDENDUMS / REVISIONS	

CONTRACT	T200911302	BRIDGE NO.	
COUNTY	NEW CASTLE	DESIGNED BY:	JP
		CHECKED BY:	HQ

DT-16

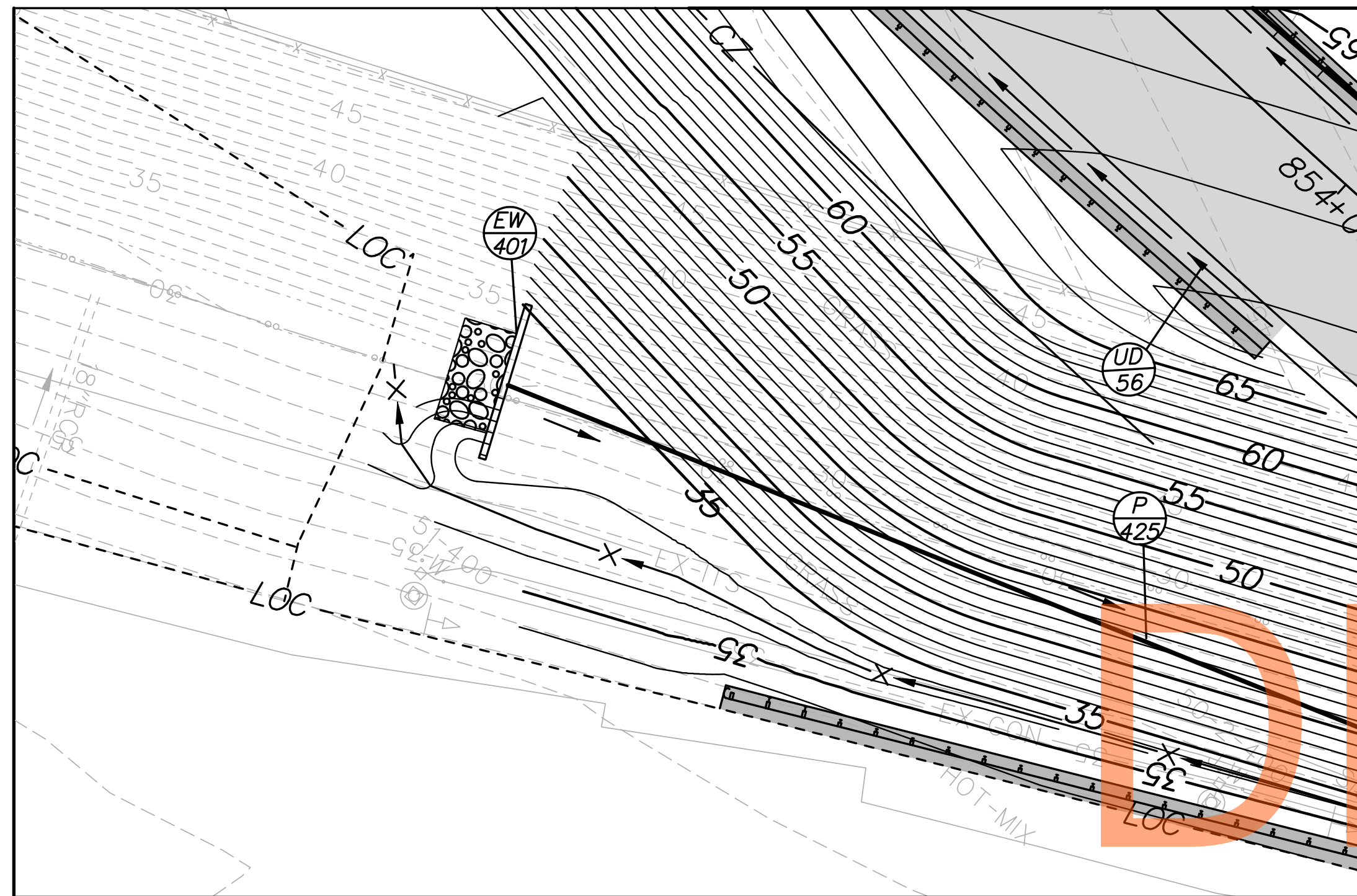

PLAN - EW/401

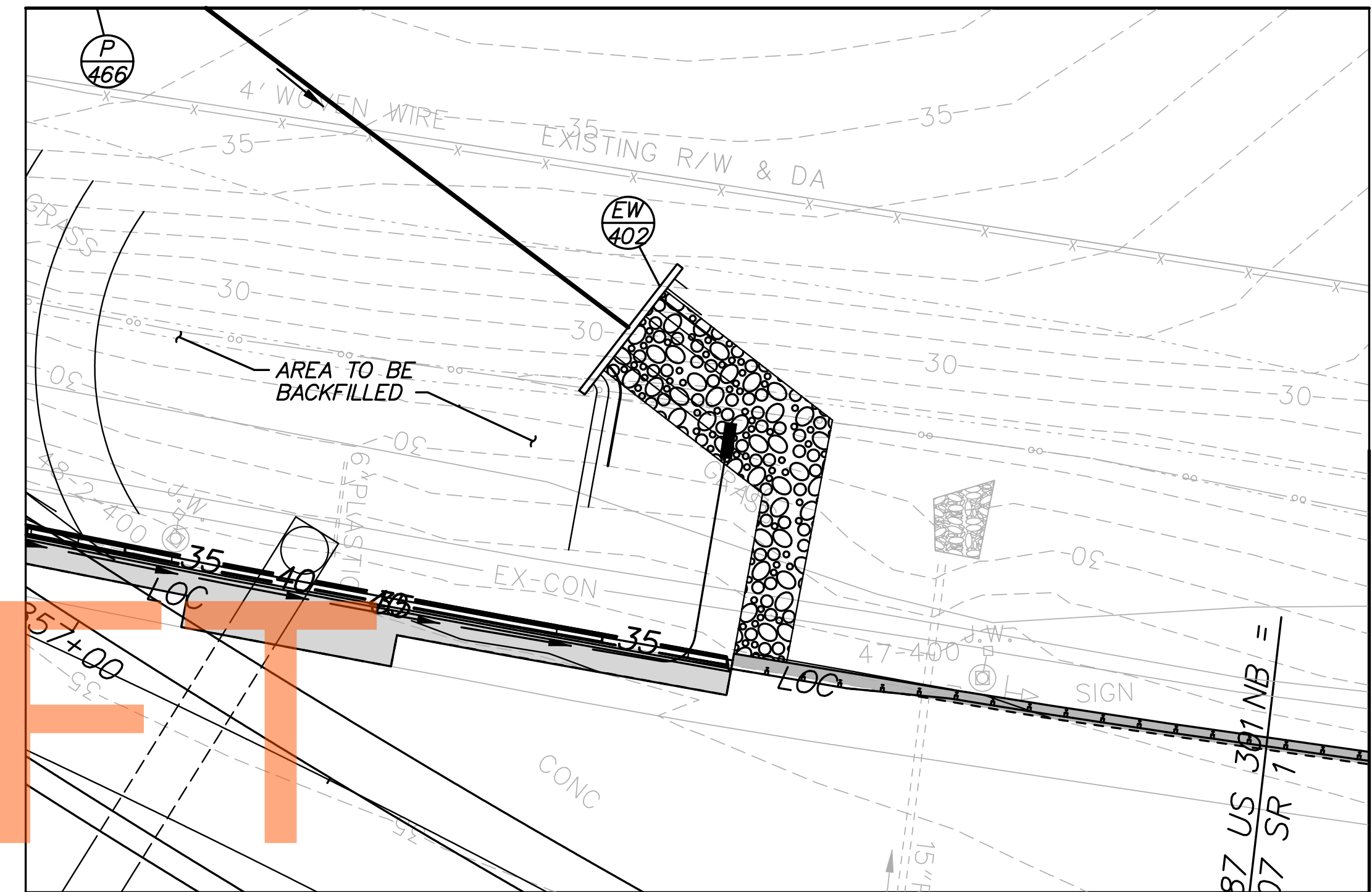
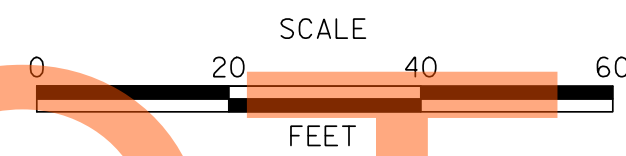

PLAN - EW/402

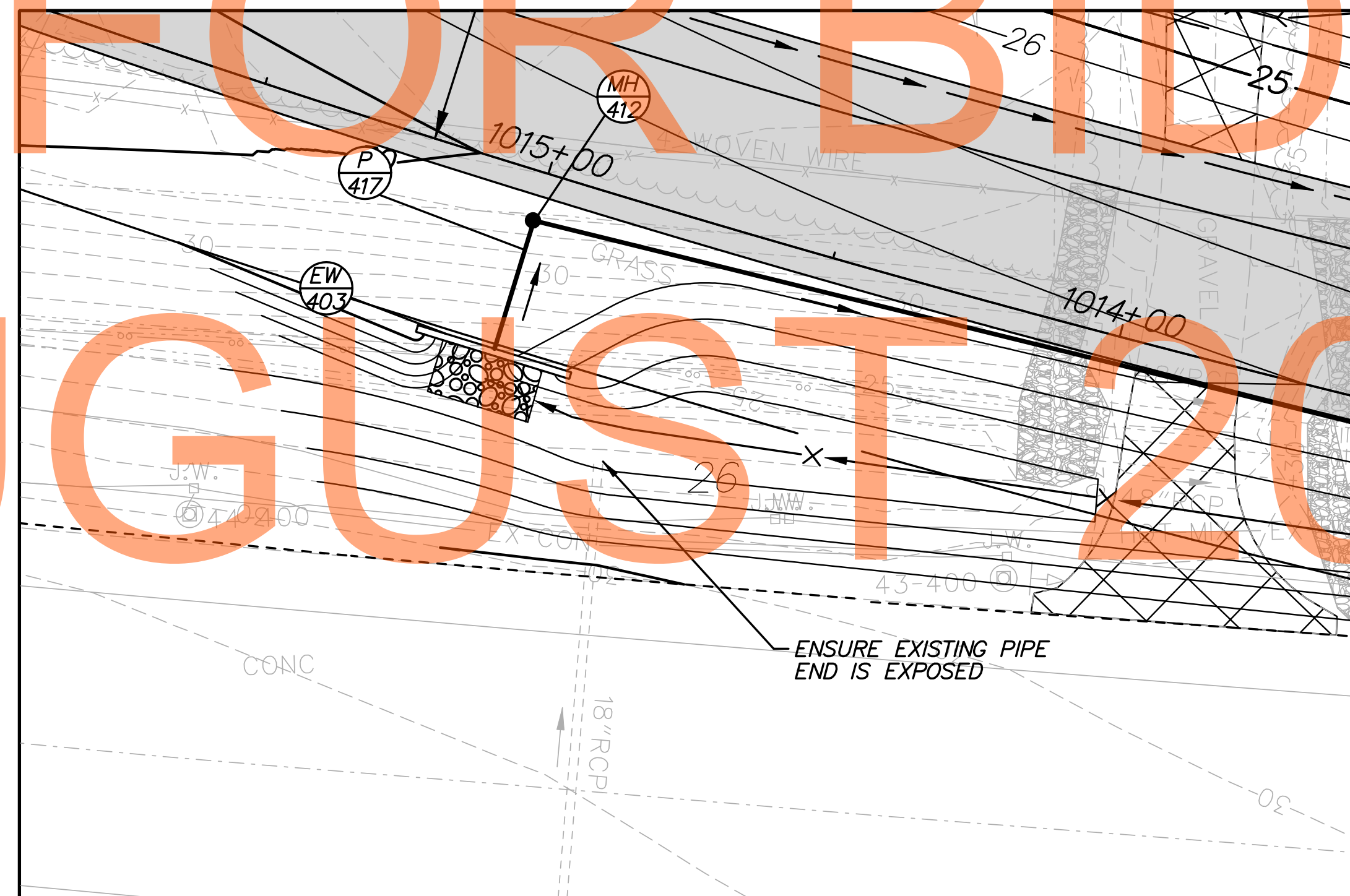
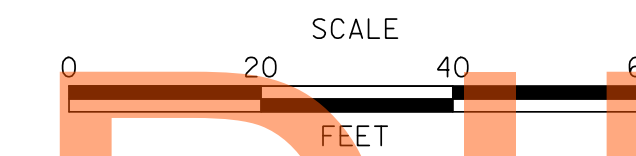

PLAN - EW/403

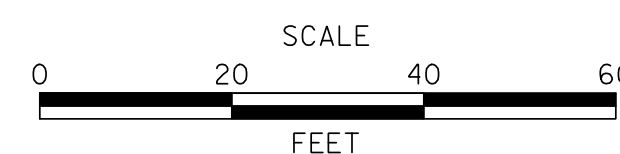

DRAFT
NOT FOR BIDDING
AUGUST 2015

P:\1953-000\contract\1b\cead\DT018U30_LB.dgn 5/27/2015 7:45:11 AM



ADDENDUMS / REVISIONS

SCALE: AS SHOWN

US 301 &
SR 1 INTERCHANGE

CONTRACT	BRIDGE NO.
T200911302	
COUNTY	DESIGNED BY: DKE
NEW CASTLE	CHECKED BY: JDC

CONSTRUCTION DETAILS

DT-18
SHEET NO.
101
TOTAL SHTS.
491

DRAFT
NOT FOR BIDDING
AUGUST 2015

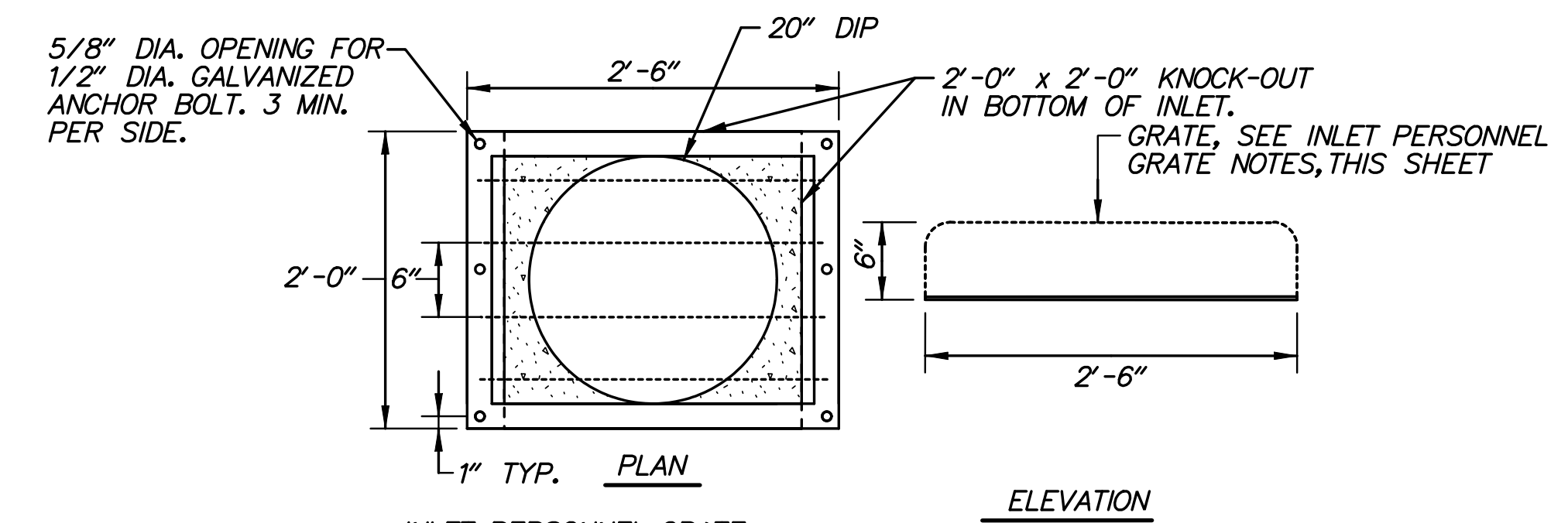
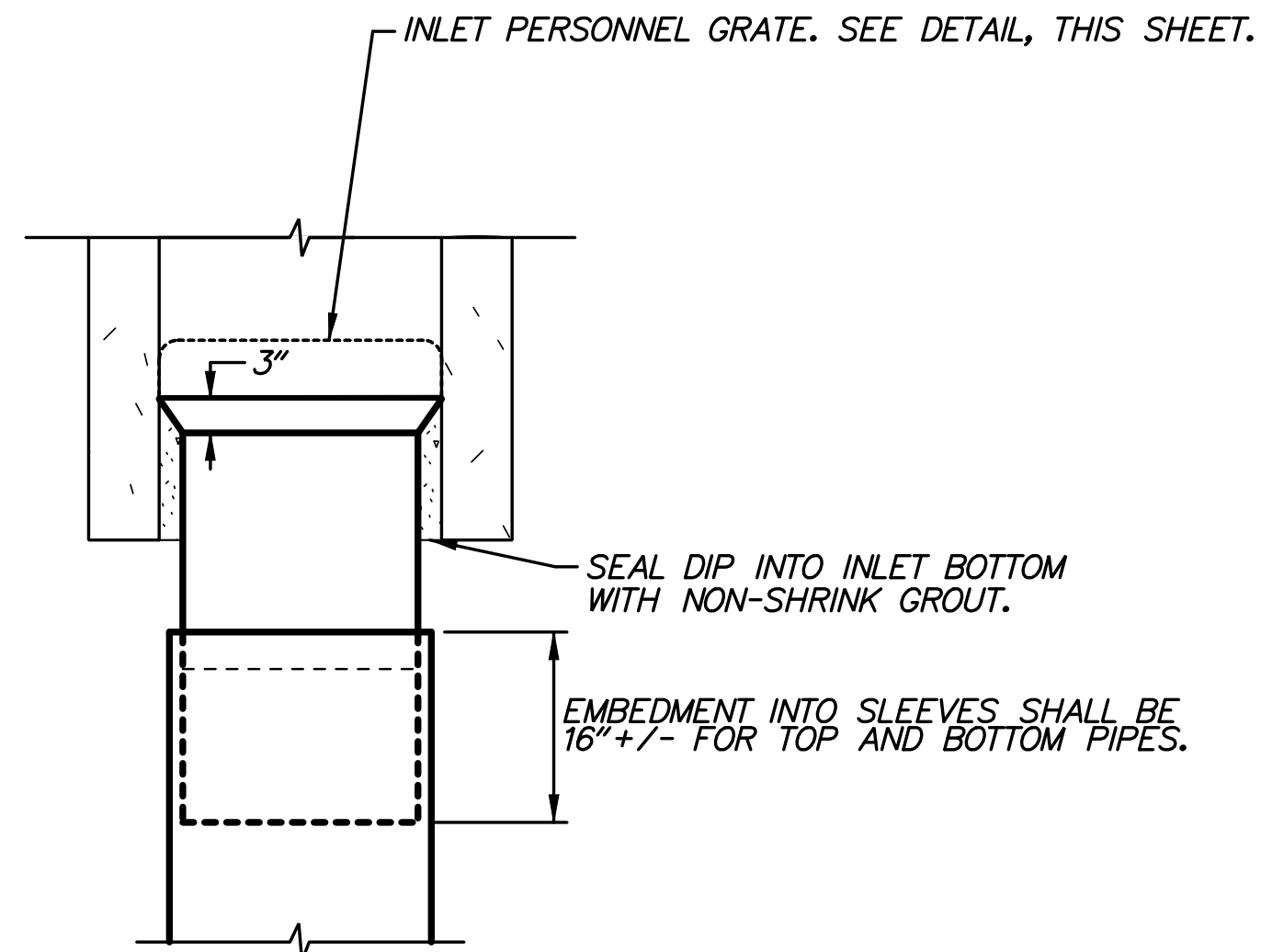

- INLET PERSONNEL GRATE**
1. INLET PERSONNEL GRATE SHALL BE PLACED AS NOTED.
 2. INLET PERSONNEL GRATE SHALL BE CONSTRUCTED OF 2" WIDE STEEL BAR FRAME AND NO. 4 STEEL REBAR AS SHOWN. NO REBAR SHALL BE WELDED TO 2" STEEL BAR FRAME.
 3. INLET PERSONNEL GRATE FRAME SHALL BE GALVANIZED PER A123.
 4. INLET PERSONNEL GRATE COST SHALL BE INCIDENTAL TO CONTRACT UNIT COST FOR INLETS DI/419 AND DI/427.

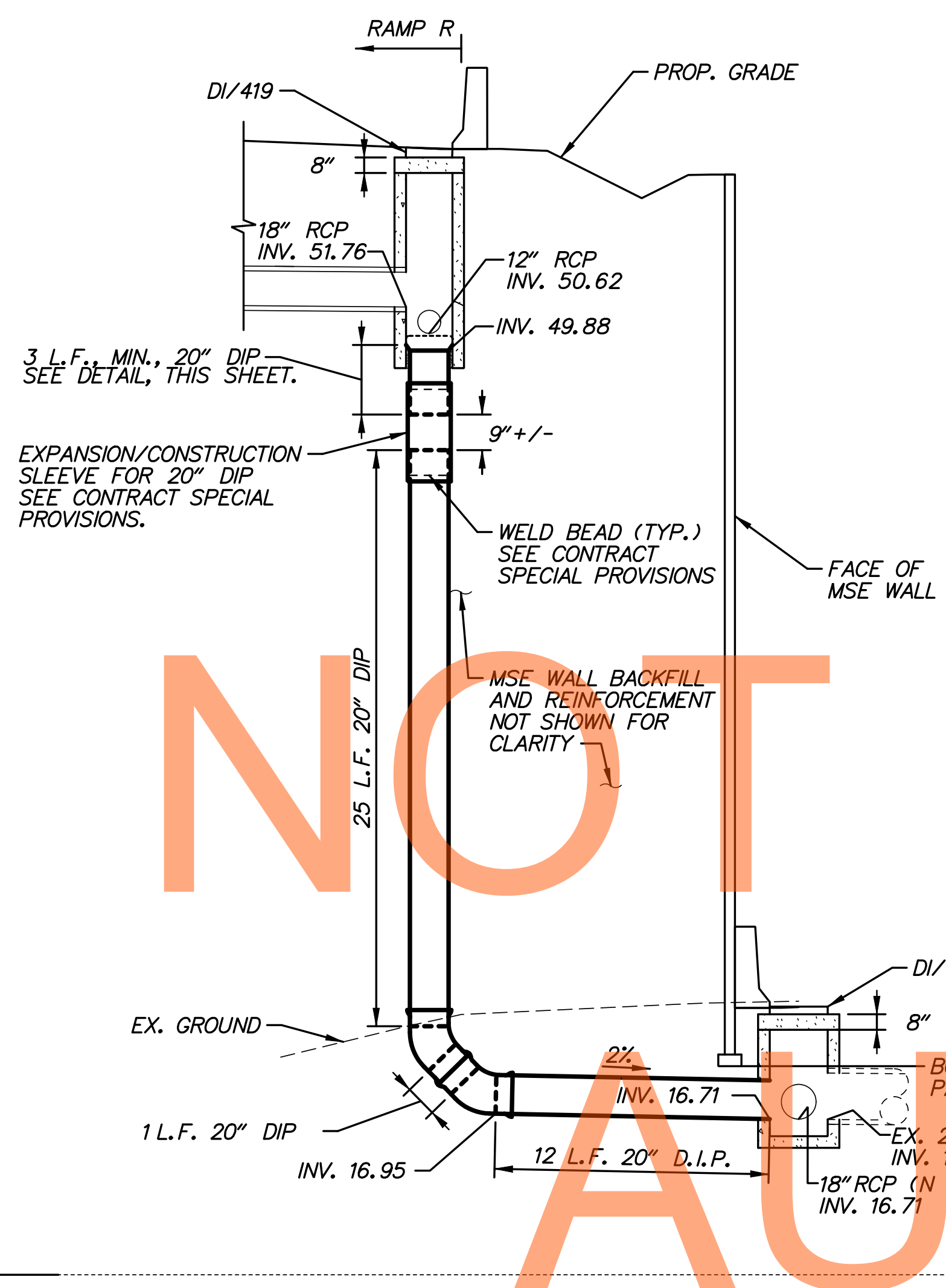
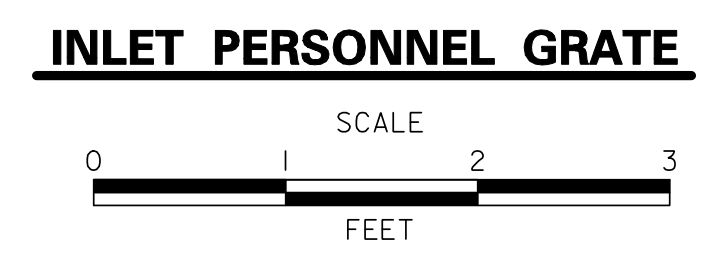

SECTION - DRAINAGE INLET DI/419

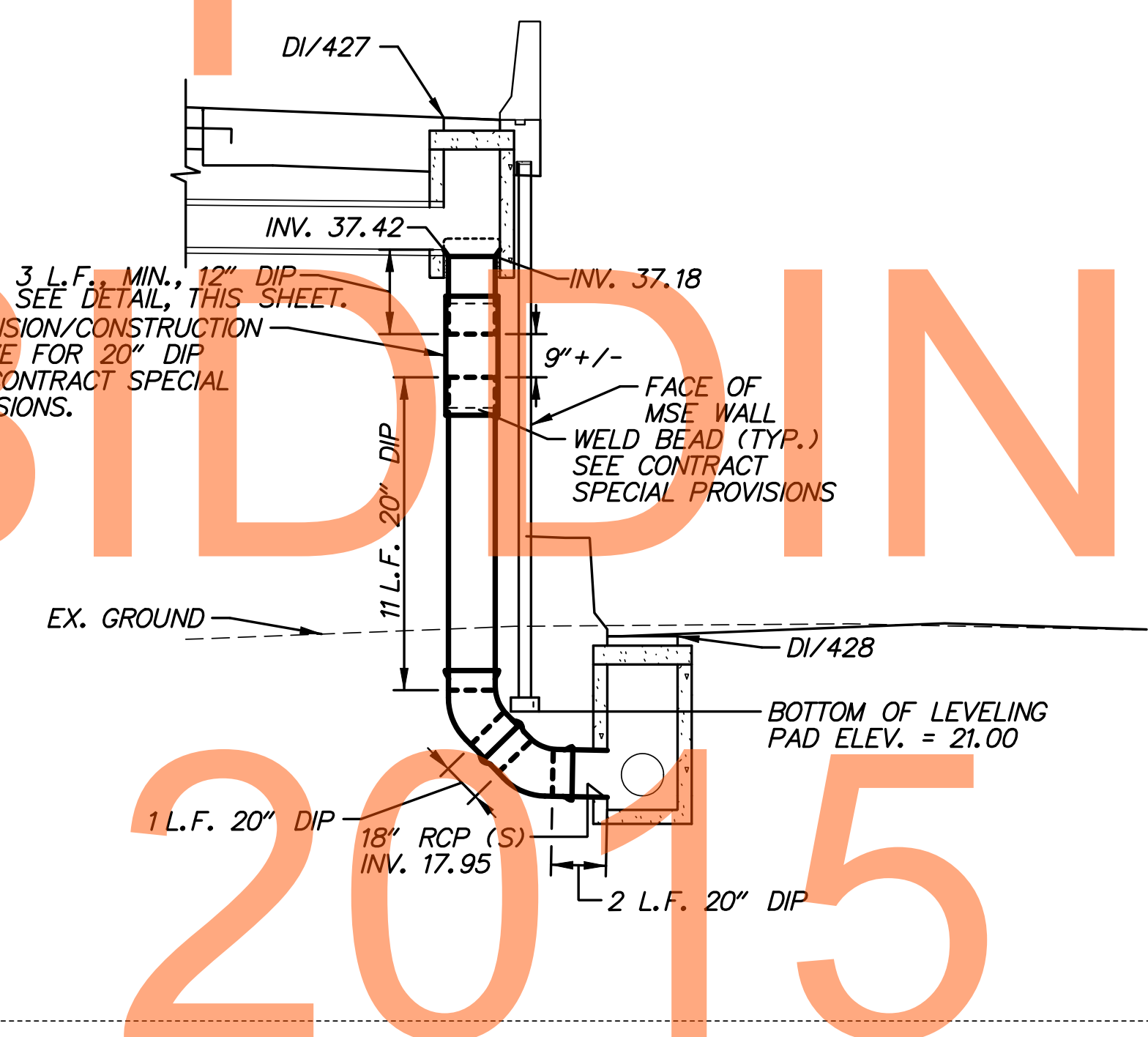

SECTION - DRAINAGE INLET DI/427

ADDENDUMS / REVISIONS	

SCALE: AS SHOWN

US 301 & SR 1 INTERCHANGE

CONTRACT T200911302	BRIDGE NO.
COUNTY NEW CASTLE	DESIGNED BY: DKE
	CHECKED BY: JDC

CONSTRUCTION DETAILS

DT-19
SHEET NO. 102
TOTAL SHTS. 491

P:\31653-000\contract\lb\cead\DT019U301.LB.dgn
 5/17/2015 7:45:28 AM

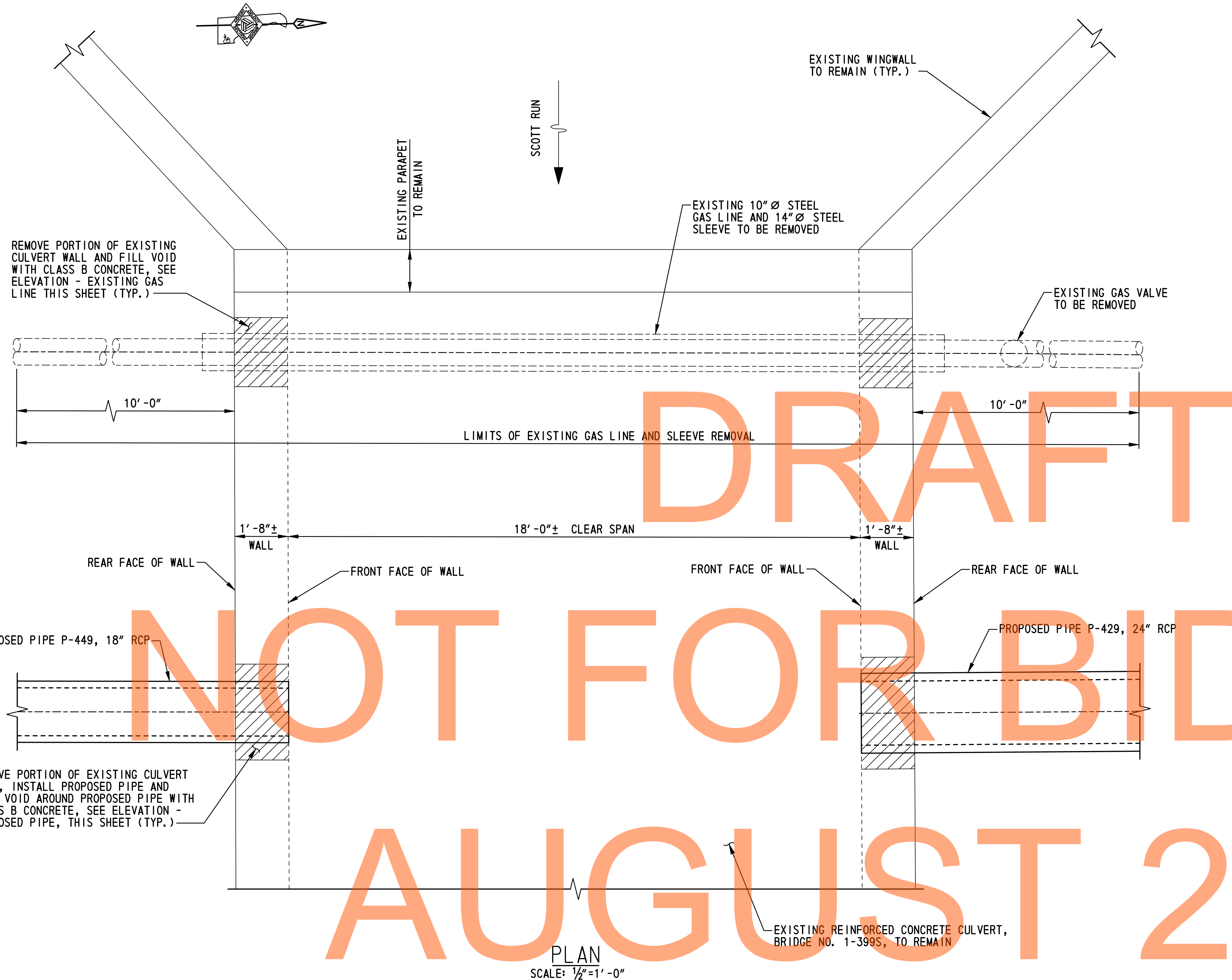
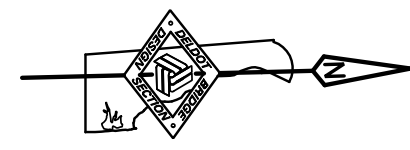

PLAN
SCALE: 1/2"=1'-0"

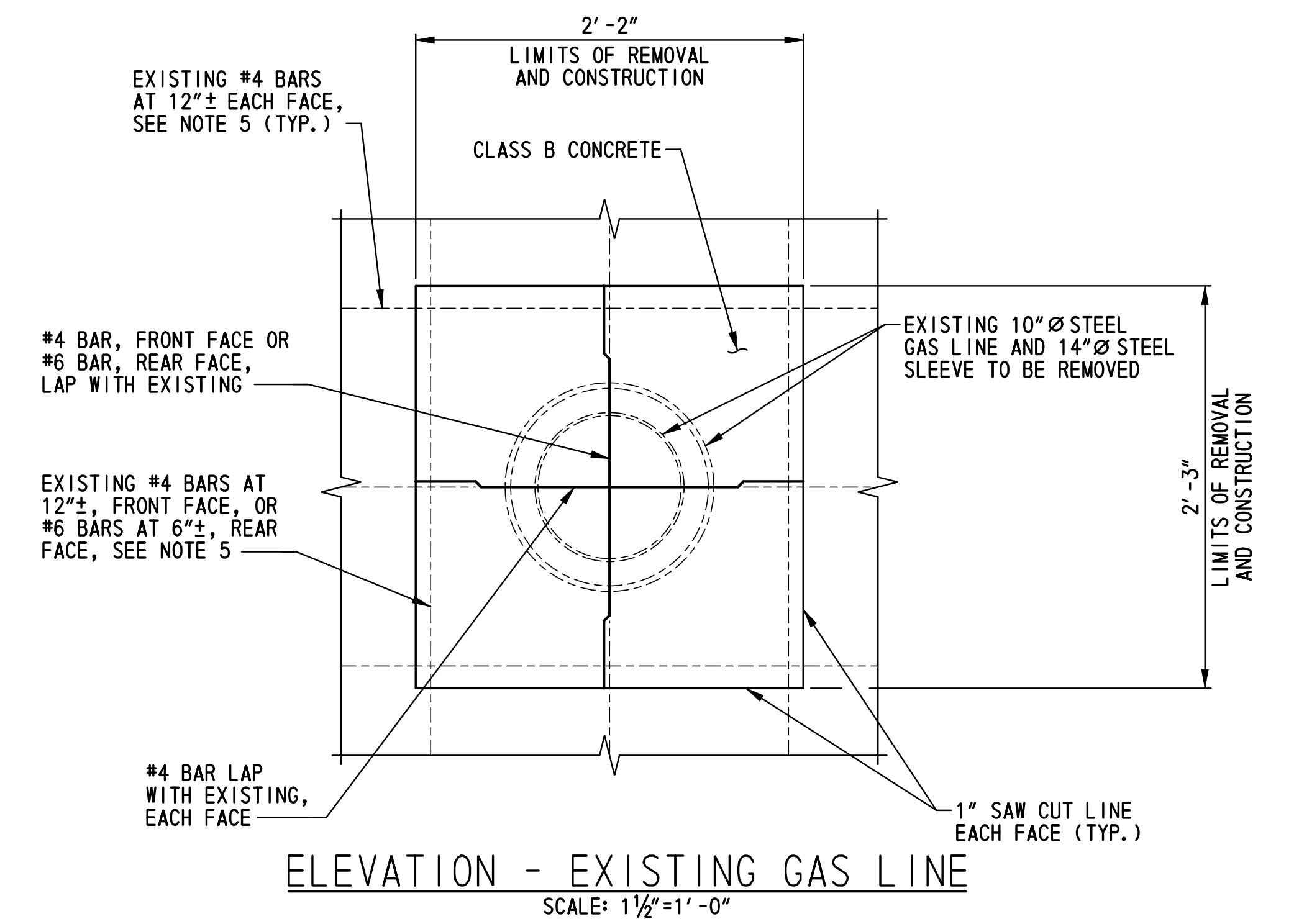

ELEVATION - EXISTING GAS LINE
SCALE: 1/2"=1'-0"

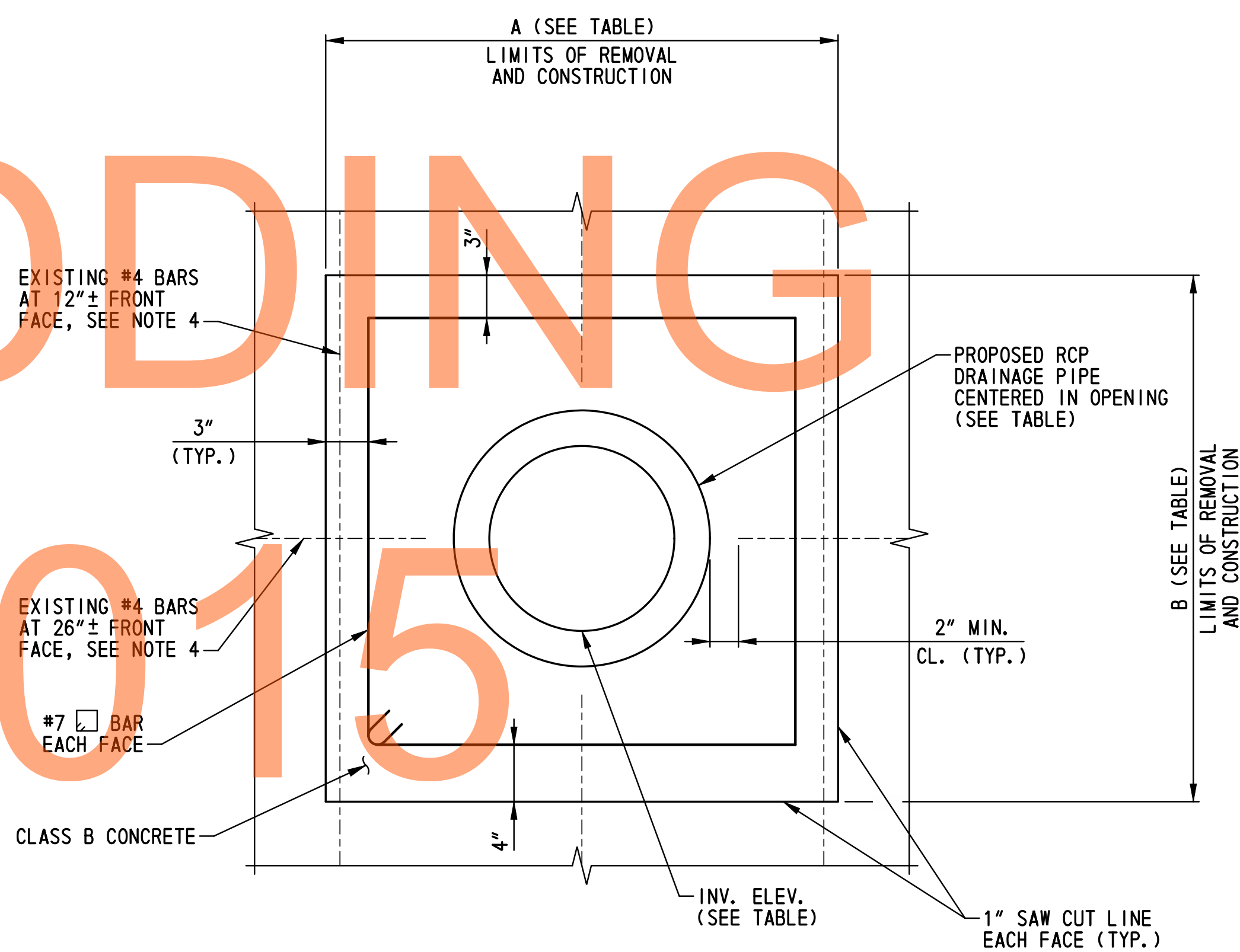

ELEVATION - PROPOSED PIPE
SCALE: 1/2"=1'-0"

NOTES:

- REMOVAL OF EXISTING GAS LINE AND SLEEVE, REMOVAL OF EXISTING GAS VALVE, SAW CUTTING, REMOVAL OF EXISTING CONCRETE, CUTTING AND CLEANING EXISTING BAR REINFORCEMENT, BACKFILLING, EPOXY BONDING COMPOUND, CLASS B CONCRETE AND BAR REINFORCEMENT SHALL BE INCIDENTAL TO ITEM 211000 - REMOVAL OF STRUCTURES AND OBSTRUCTIONS.
- EXISTING GAS LINE TO BE RELOCATED, ABANDONED AND PURGED BY OTHERS.
- EXISTING REINFORCEMENT LAYOUT DETAILS FROM ORIGINAL PLANS. CONTRACTOR SHALL VERIFY ALL DIMENSIONS IN THE FIELD. CONTRACTOR IS RESPONSIBLE TO ADJUST DETAILS AS REQUIRED TO ACCOUNT FOR VARYING FIELD CONDITIONS.
- CUT EXISTING REINFORCEMENT AS NEEDED TO INSTALL PROPOSED PIPE AND PROVIDE MINIMUM CLEAR DISTANCE. ALL EXPOSED REINFORCEMENT TO REMAIN AND INCORPORATED INTO PROPOSED CONSTRUCTION SHALL BE BLAST CLEANED.
- CLEAN ALL EXPOSED EXISTING REINFORCEMENT BEFORE LAPPING WITH NEW BARS OF EQUAL SIZE AS REQUIRED.
- BAR REINFORCEMENT SHALL CONFORM TO AASHTO M31, GRADE 60.
- CLEAN AND APPLY EPOXY BONDING COMPOUND TO ALL REMOVAL SURFACES PRIOR TO PLACING CONCRETE.

PIPE	DIA.	A	B	INV. ELEV.*
P-429	24"	3'-6"	3'-7"	2.80
P-449	18"	3'-0"	3'-1"	1.93

* DOWNSTREAM, AT FRONT FACE OF WALL

M:\31653-000\CONTRACT 18\CAD\DT020030_1B.dgn
 7/30/2015 10:55:51 AM