

**BEGIN  
CONTRACT T200811301  
STATION 62+75**

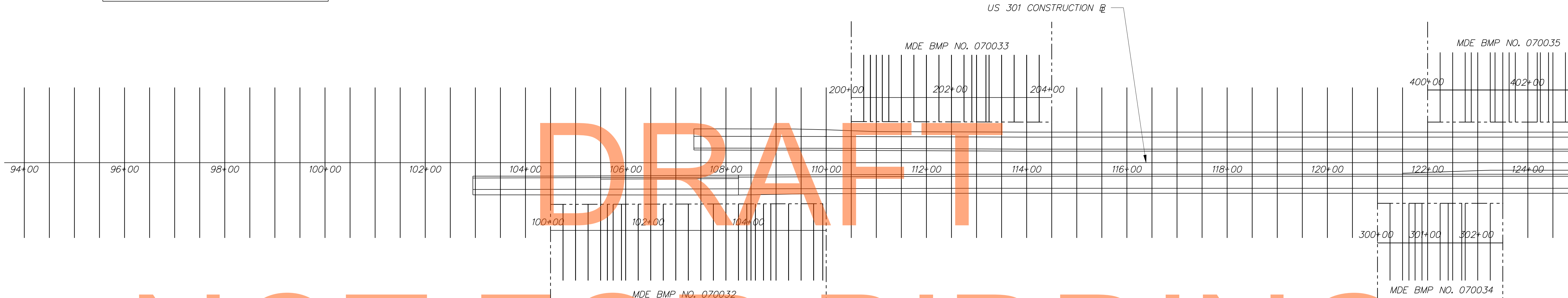

**NOT FOR BIDDING**

**ALIGNMENT 2015**

CROSS SECTION INDEX

METHOD OF CROSS SECTIONS	STATION	SHEETS
US 301 MAINLINE	STATION 94+00 TO STATION 261+00	SHEETS 1 - 8
STRAWBERRY LANE	STATION 1000+00 TO STATION 1021+00	SHEETS 9 - 146
MIDDLETOWN WARWICK ROAD	STATION 1100+50 TO STATION 1131+00	SHEETS 147 - 164
MIDDLETOWN WARWICK ROAD	STATION 737+00 TO STATION 748+00	SHEETS 165 - 185
WARWICK/LEVELS ROAD	STATION 1200+50 TO STATION 1317+00	SHEETS 186 - 193
LEVELS ROAD	STATION 661+00 TO STATION 666+50	SHEETS 194 - 274
RAMP A	STATION 502+00 TO STATION 511+50	SHEETS 275 - 278
RAMP B	STATION 602+00 TO STATION 608+50	SHEETS 279 - 285
RAMP C	STATION 10+30 TO STATION 14+50	SHEETS 286 - 290
RAMP D	STATION 301+00 TO STATION 314+50	SHEETS 291 - 294
RAMP E	STATION 400+50 TO STATION 414+00	SHEETS 295 - 304
RAMP F	STATION 53+50 TO STATION 64+10	SHEETS 305 - 314
MIDDLENECK ROAD	STATION 33+50 TO STATION 32+00	SHEET 315 - 316
STRAWBERRY ACCESS A	STATION 10+50 TO STATION 17+59	SHEETS 317 - 318
STRAWBERRY ACCESS B	STATION 20+50 TO STATION 23+08	SHEETS 319 - 322
PHASE 1 SB CROSSOVER	STATION 401+00 TO STATION 414+00	SHEETS 323 - 324
PHASE 4 NB CROSSOVER	STATION 493+00 TO STATION 506+00	SHEETS 325 - 333
PHASE 4 WARWICK CROSSOVER	STATION 364+00 TO STATION 392+00	SHEETS 334 - 342
PHASE 4 WARWICK INTERSECTION	STATION 1+50 TO STATION 2+00	SHEETS 343 - 361
		SHEET 362

CROSS SECTION INDEX

BMP NO. 070032	SHEETS 363 - 372
BMP NO. 070033	SHEETS 373 - 379
BMP NO. 070034	SHEETS 380 - 384
BMP NO. 070035	SHEETS 385 - 390
BMP NO. 604	SHEETS 391 - 400
BMP NO. 605	SHEETS 401 - 409
BMP NO. 606	SHEETS 410 - 415
BMP NO. 607	SHEETS 416 - 424
BMP NO. 608	SHEETS 425 - 431
BMP NO. 609	SHEETS 432 - 439
BMP NO. 610	SHEETS 440 - 455
BMP NO. 611	SHEETS 456 - 472
BMP NO. 612	SHEETS 473 - 481
BMP NO. 613	SHEETS 482 - 489
BMP NO. 616	SHEETS 490 - 510
BMP NO. 617	SHEETS 511 - 517
BMP NO. 618	SHEETS 518 - 524
BMP NO. 619	SHEETS 525 - 530
BMP NO. 620	SHEETS 531 - 539

**LEGEND**

--- CROSS SECTION MATCHLINE

**NOTE:**

ALL CROSS SECTIONS ARE TAKEN RADIAL TO A BASELINE AND AT 50' INTERVALS UNLESS OTHERWISE NOTED.



**US 301  
MARYLAND STATE LINE  
TO LEVELS ROAD**

CONTRACT T200811301	BRIDGE NO.
COUNTY NEW CASTLE	DESIGNED BY: MJB
	CHECKED BY: SKH

**METHOD OF  
CROSS SECTIONS**

SHEET NO. 1
TOTAL SHTS. 539

**LIMIT OF CONSTRUCTION  
CONTRACT T200811301  
STATION 1001+00**

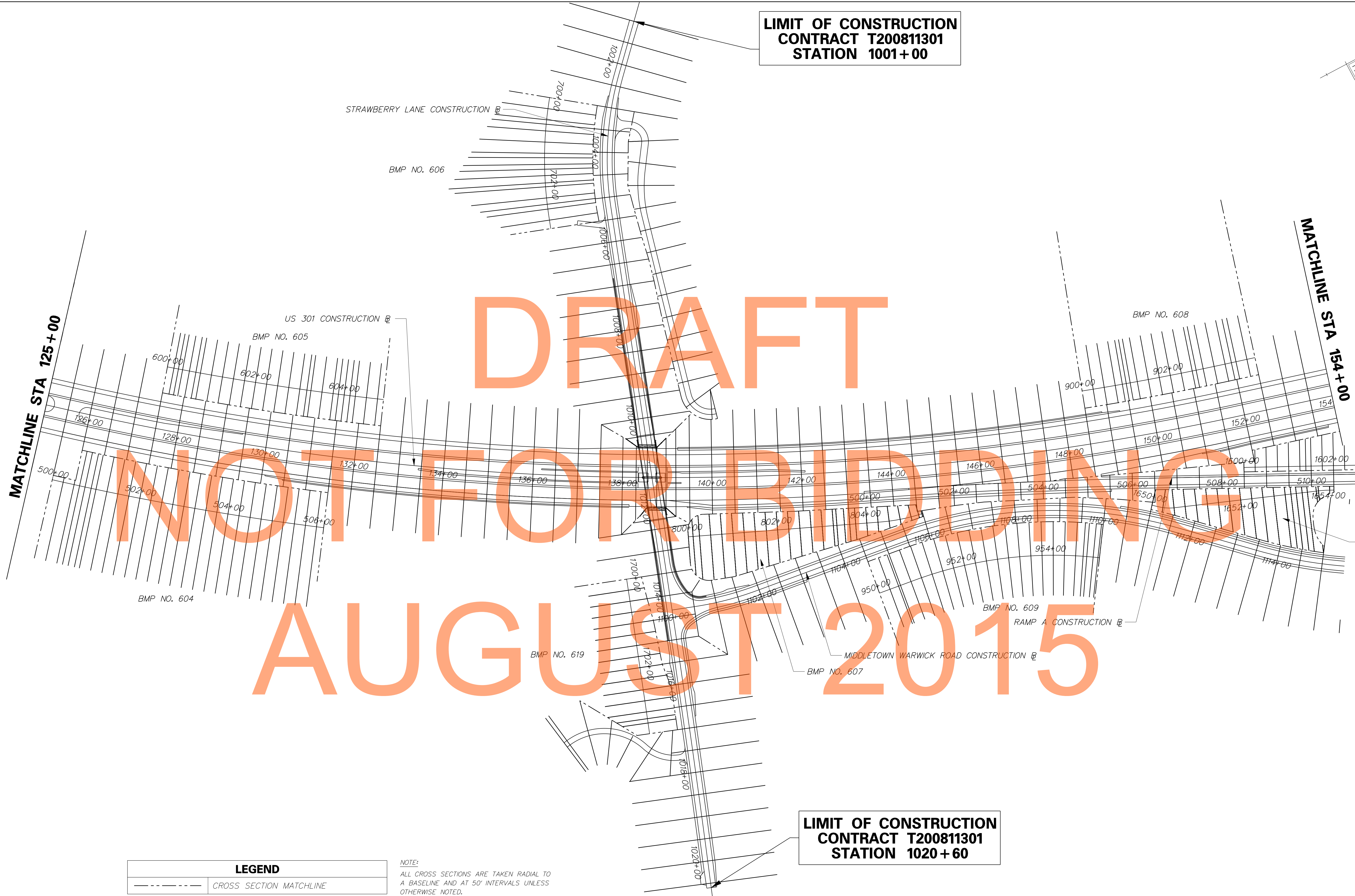
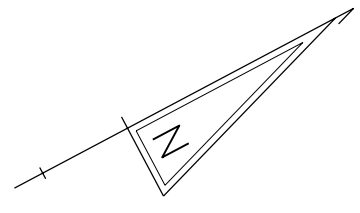

LEGEND	
	CROSS SECTION MATCHLINE

*NOTE:*  
ALL CROSS SECTIONS ARE TAKEN RADIAL TO A BASELINE AND AT 50' INTERVALS UNLESS OTHERWISE NOTED.

**LIMIT OF CONSTRUCTION  
CONTRACT T200811301  
STATION 1020+60**

J:\2008 PROJECTS\E3X34801\700CADD\750AET\XS\DT\_301AET\_002\_XS.DGN



ADDENDUMS / REVISIONS

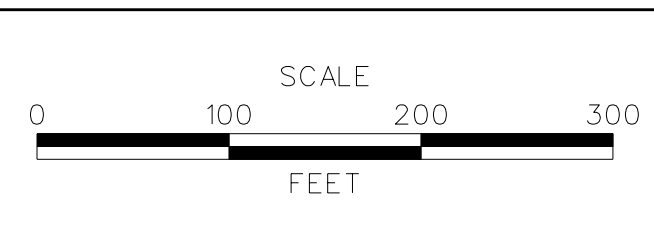

**US 301  
MARYLAND STATE LINE  
TO LEVELS ROAD**

CONTRACT T200811301	BRIDGE NO.
COUNTY NEW CASTLE	DESIGNED BY: MJB
	CHECKED BY: SKH

METHOD OF CROSS SECTIONS

SHEET NO. 2
TOTAL SHTS. 539

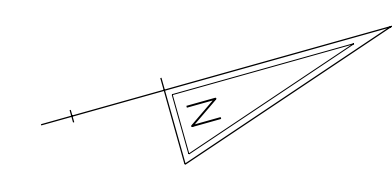

DRAFT  
NOT FOR BIDDING  
AUGUST 2015

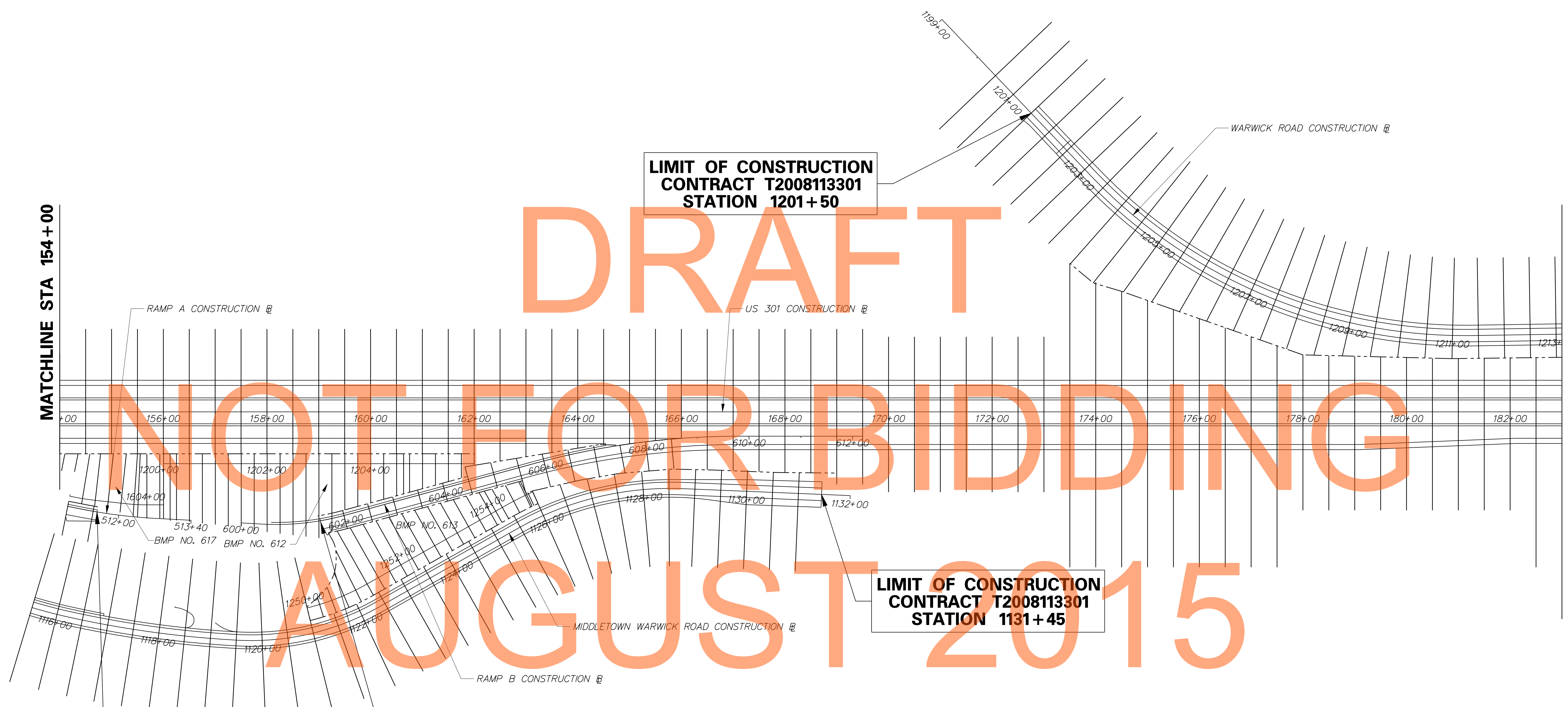

LIMIT OF CONSTRUCTION  
CONTRACT T2008113301  
STATION 1201+50

LIMIT OF CONSTRUCTION  
CONTRACT T2008113301  
STATION 1131+45

LIMIT OF CONSTRUCTION  
CONTRACT T2008113301  
STATION 601+53

LIMIT OF CONSTRUCTION  
CONTRACT T2008113301  
STATION 511+58

LEGEND	
-----	CROSS SECTION MATCHLINE

NOTE:  
ALL CROSS SECTIONS ARE TAKEN RADIAL TO  
A BASELINE AND AT 50' INTERVALS UNLESS  
OTHERWISE NOTED.

J:\2008 PROJECTS\E3X34801\700CADD\750AET\X5\DT\_30\AET\_003\_XS.DGN



ADDENDUMS / REVISIONS

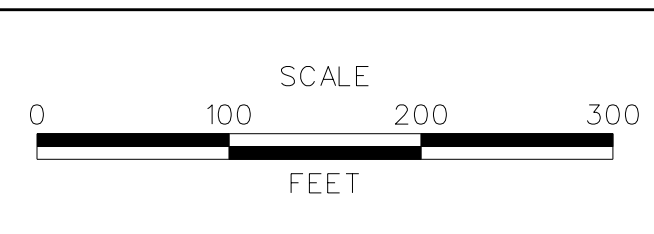

US 301  
MARYLAND STATE LINE  
TO LEVELS ROAD

CONTRACT T200811301	BRIDGE NO.
COUNTY NEW CASTLE	DESIGNED BY: MJB CHECKED BY: SKH

METHOD OF CROSS SECTIONS	SHEET NO. 3
	TOTAL SHTS. 539

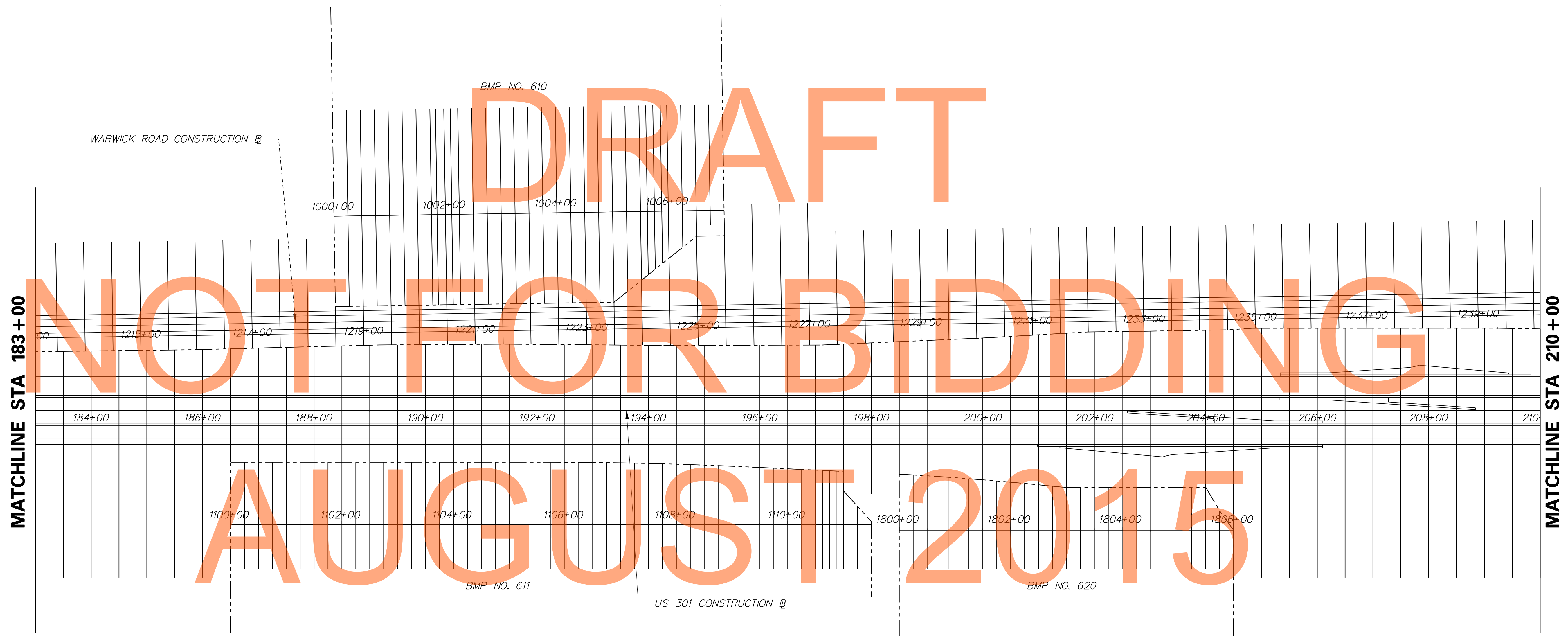
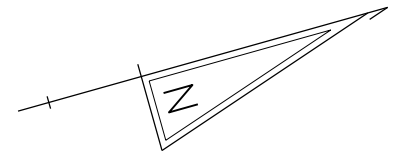

LEGEND	
-----	CROSS SECTION MATCHLINE

NOTE:  
ALL CROSS SECTIONS ARE TAKEN RADIAL TO  
A BASELINE AND AT 50' INTERVALS UNLESS  
OTHERWISE NOTED.

J:\2008 PROJECTS\34801\700CADD\750AET\XS\DT\_30AET\_004\_XS.DGN

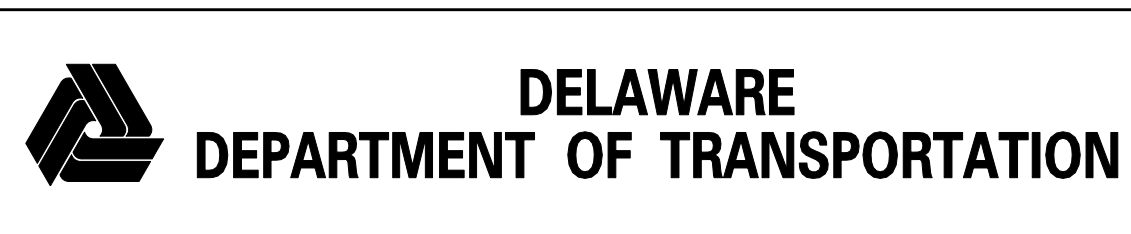

ADDENDUMS / REVISIONS

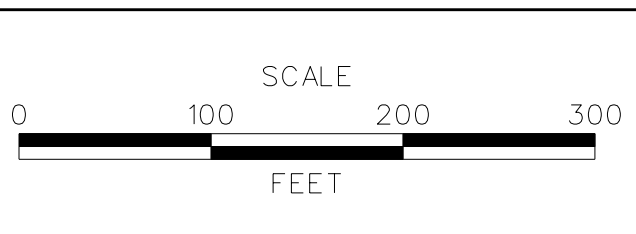

**US 301**  
**MARYLAND STATE LINE**  
**TO LEVELS ROAD**

CONTRACT T200811301	BRIDGE NO.
COUNTY NEW CASTLE	DESIGNED BY: MJB
	CHECKED BY: SKH

METHOD OF CROSS SECTIONS

SHEET NO. 4
TOTAL SHTS. 539

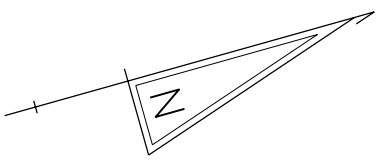

**LIMIT OF CONSTRUCTION  
CONTRACT T200811301  
STATION 32+00**

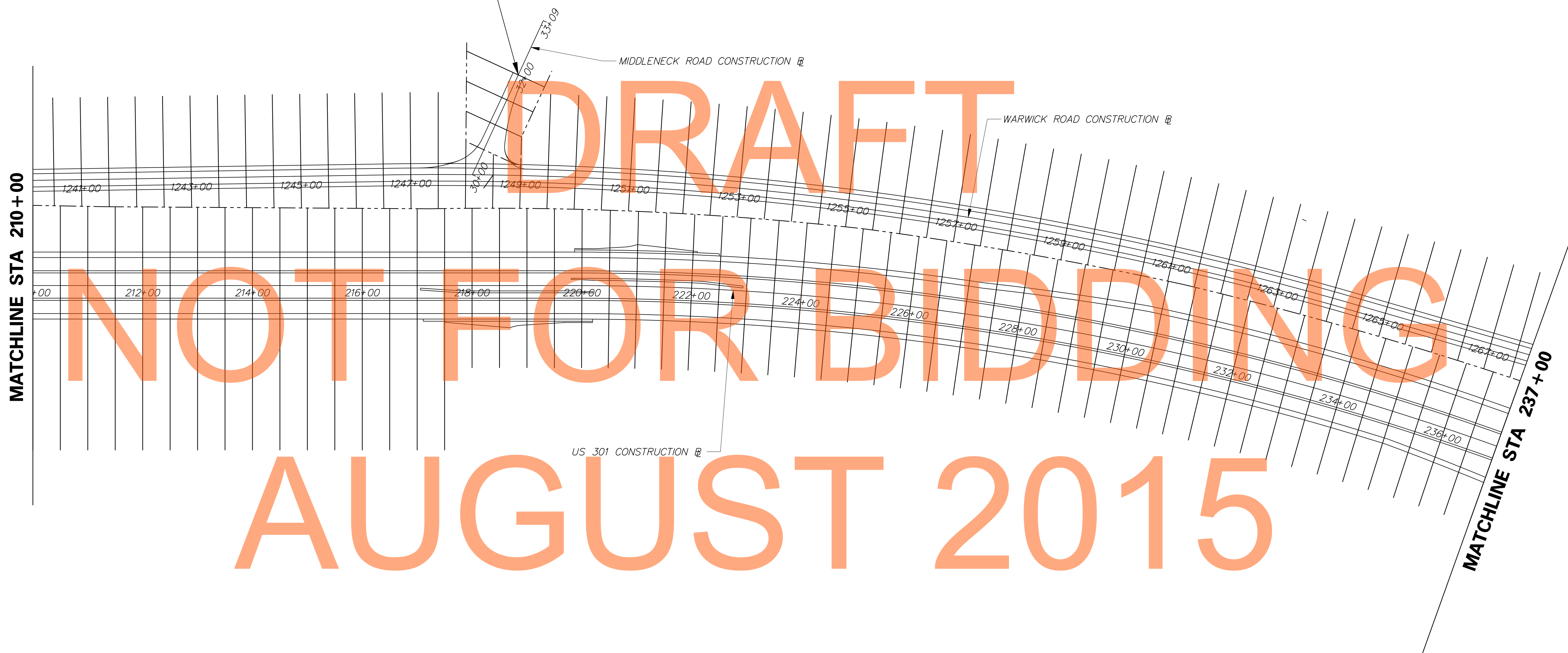

LEGEND	
-----	CROSS SECTION MATCHLINE

**NOTE:**  
ALL CROSS SECTIONS ARE TAKEN RADIAL TO A BASELINE AND AT 50' INTERVALS UNLESS OTHERWISE NOTED.

J:\2008 PROJECTS\34801\700CADD\750AET\XS\DT\_30\AET\_005\_XS.DGN



ADDENDUMS / REVISIONS

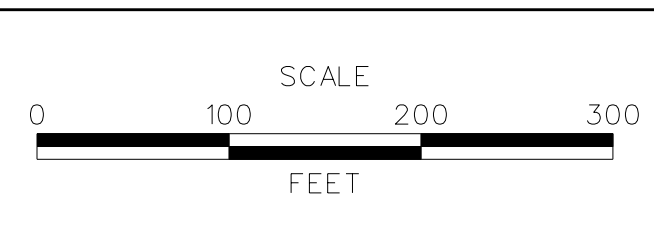

**US 301  
MARYLAND STATE LINE  
TO LEVELS ROAD**

CONTRACT T200811301	BRIDGE NO.
COUNTY NEW CASTLE	DESIGNED BY: MJB
	CHECKED BY: SKH

<b>METHOD OF CROSS SECTIONS</b>
SHEET NO. 5
TOTAL SHTS. 539

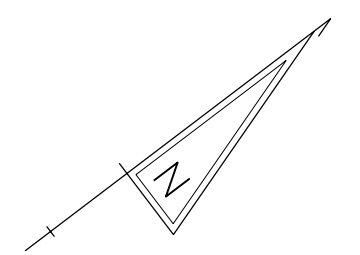

**END  
CONTRACT T200811301  
STATION 258+00**

**SEE  
CONTRACT T200911303  
STATION 258+00 AHEAD**

NOT FOR BIDDING  
AUGUST 2015

MATCHLINE STA 237 + 00

MATCHLINE STA 1304 + 00

LEGEND	
- - - - -	CROSS SECTION MATCHLINE

NOTE:  
ALL CROSS SECTIONS ARE TAKEN RADIAL TO  
A BASELINE AND AT 50' INTERVALS UNLESS  
OTHERWISE NOTED.

J:\2008 PROJECTS\E3X34801\700CADD\750AET\XS\DT\_301AET\_006\_XS.DGN



ADDENDUMS / REVISIONS	

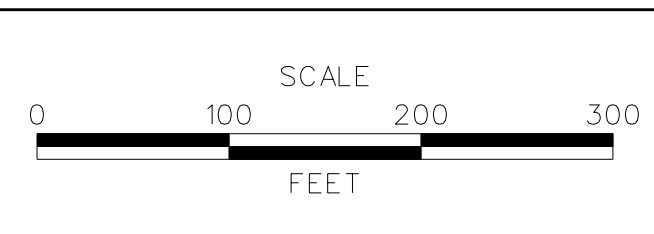

**US 301  
MARYLAND STATE LINE  
TO LEVELS ROAD**

CONTRACT T200811301	BRIDGE NO.
COUNTY NEW CASTLE	DESIGNED BY: MJB
	CHECKED BY: SKH

<b>METHOD OF CROSS SECTIONS</b>
SHEET NO. 6
TOTAL SHTS. 539

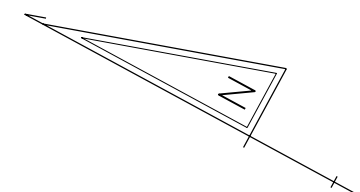

LIMIT OF CONSTRUCTION  
CONTRACT T200811301  
STATION 748+00

LIMIT OF CONSTRUCTION  
CONTRACT T200811301  
STATION 667+00

LIMIT OF CONSTRUCTION  
CONTRACT T200811301  
STATION 732+00



LEGEND	
-----	CROSS SECTION MATCHLINE

NOTE:  
ALL CROSS SECTIONS ARE TAKEN RADIAL TO  
A BASELINE AND AT 50' INTERVALS UNLESS  
OTHERWISE NOTED.

J:\2008 PROJECTS\34801\700CADD\750AET\XS\DT\_30\AET\_007\_XS.DGN



ADDENDUMS / REVISIONS

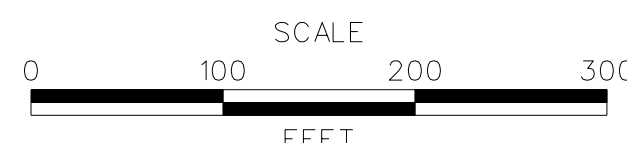

US 301  
MARYLAND STATE LINE  
TO LEVELS ROAD

CONTRACT T200811301	BRIDGE NO.
COUNTY NEW CASTLE	DESIGNED BY: MJB CHECKED BY: SKH

METHOD OF  
CROSS SECTIONS

SHEET NO. 7
TOTAL SHTS. 539

**PHASE 1 - SOUTHBOUND MARYLAND CROSSOVER**

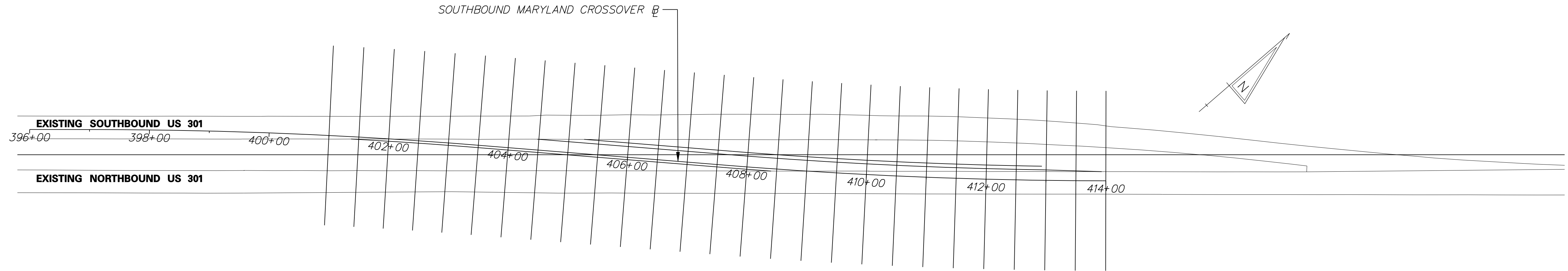

**PHASE 4 - NORTHBOUND MARYLAND CROSSOVER**

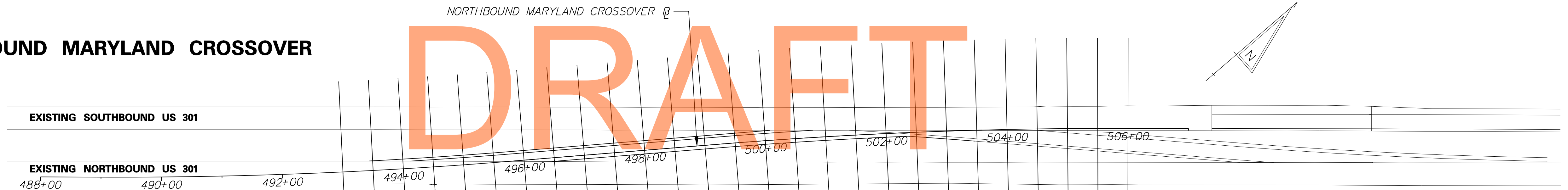

DRAFT  
NOT FOR BIDDING

**PHASE 4 - WARWICK CROSSOVER & WARWICK INTERSECTION**

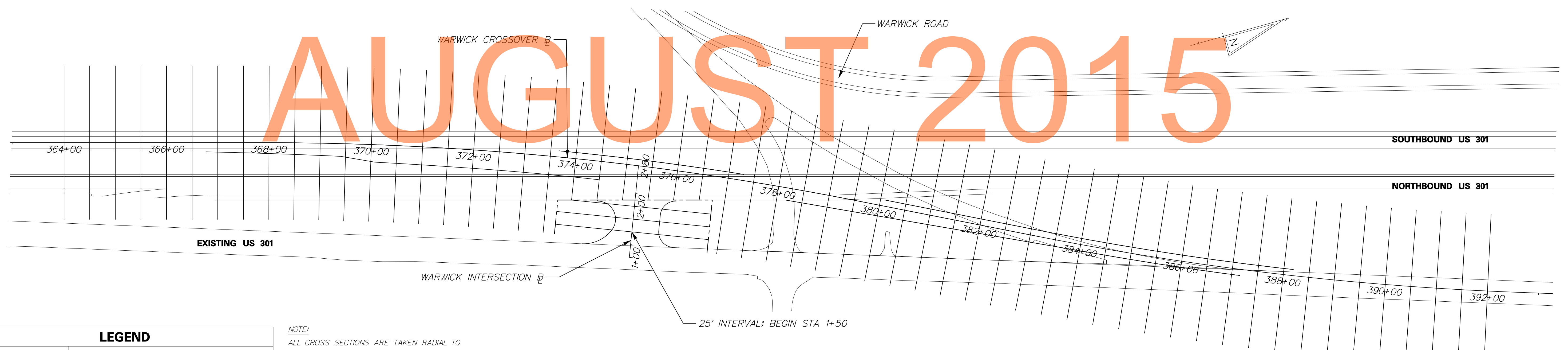

AUGUST 2015

LEGEND	
-----	CROSS SECTION MATCHLINE

*NOTE:*  
ALL CROSS SECTIONS ARE TAKEN RADIAL TO A BASELINE AND AT 50' INTERVALS UNLESS OTHERWISE NOTED.

25' INTERVAL; BEGIN STA 1+50



ADDENDUMS / REVISIONS

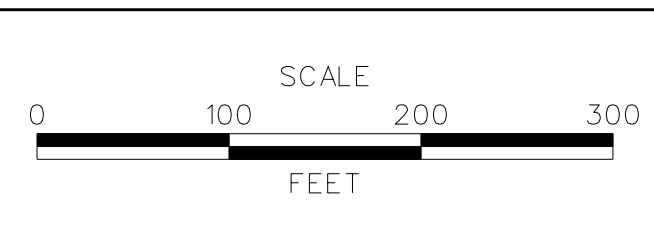

**US 301  
MARYLAND STATE LINE  
TO LEVELS ROAD**

CONTRACT T200811301	BRIDGE NO.
COUNTY NEW CASTLE	DESIGNED BY: MJB
	CHECKED BY: SKH

METHOD OF CROSS SECTIONS

SHEET NO. 8
TOTAL SHTS. 539

J:\2008 PROJECTS\E3X34801\700CADD\750AET\XS\DT\_301AET\_008\_XS.DGN



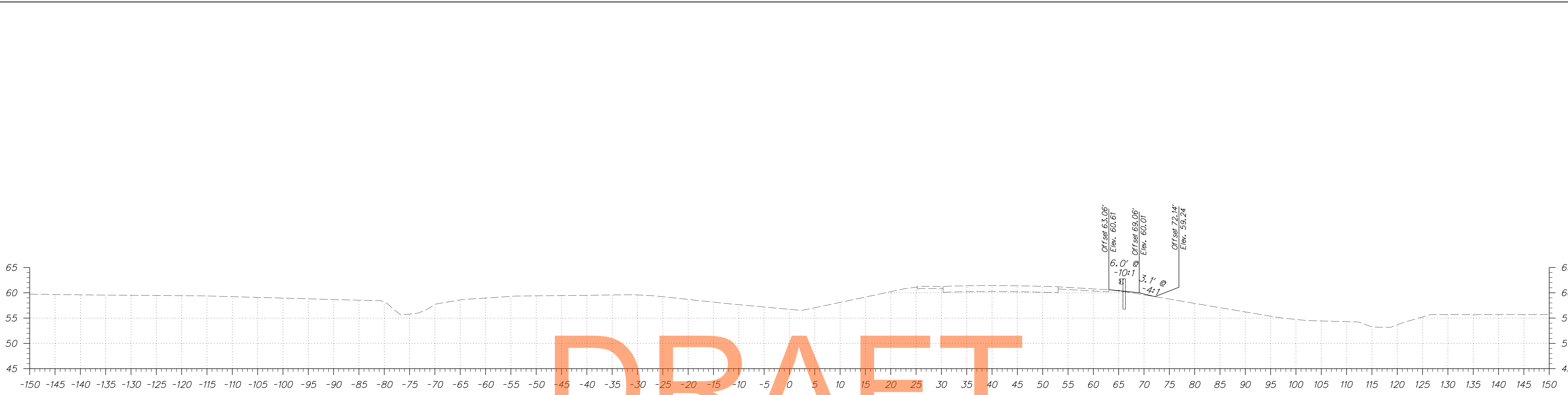

DRAFT



NOT FOR BIDDING

AUGUST 2015

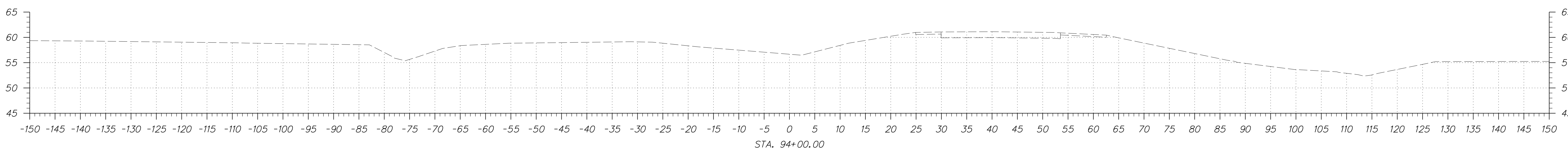

ADDENDUMS / REVISIONS	

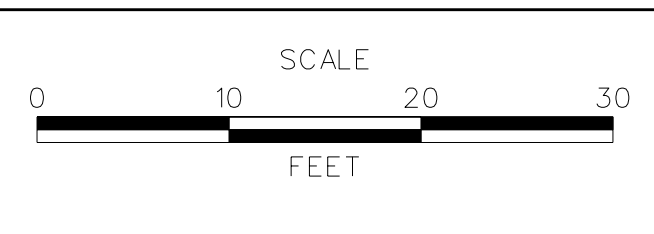

**US 301  
MARYLAND STATE LINE  
TO LEVELS ROAD**

CONTRACT T200811301	BRIDGE NO.
COUNTY NEW CASTLE	DESIGNED BY: JEG
	CHECKED BY: MFM

<b>CROSS SECTIONS US 301 MAINLINE</b>	SHEET NO. 9
	TOTAL SHTS. 539

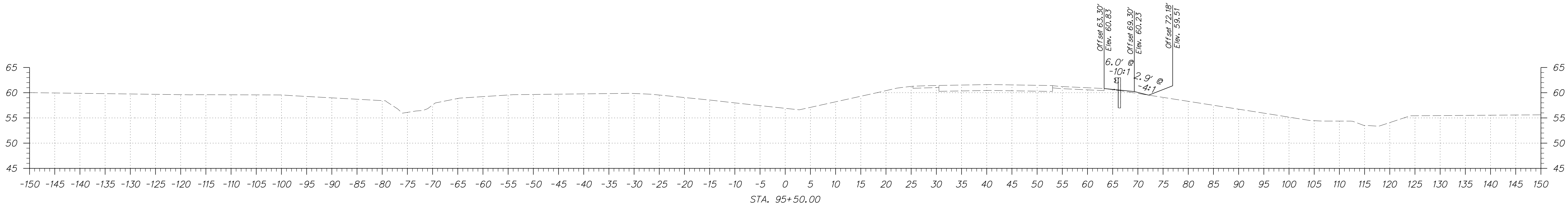
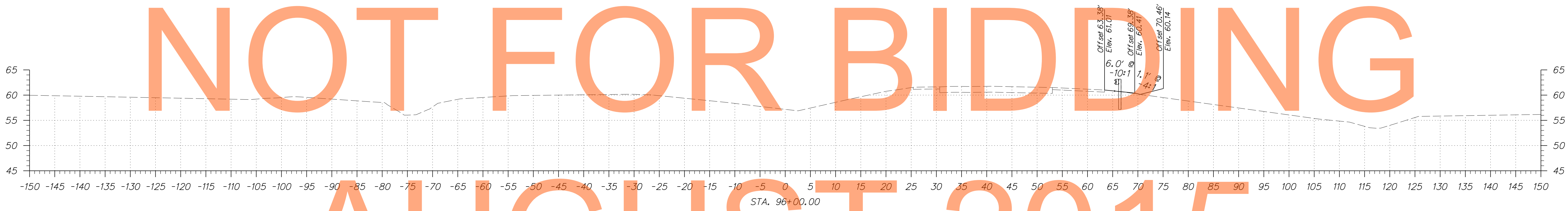
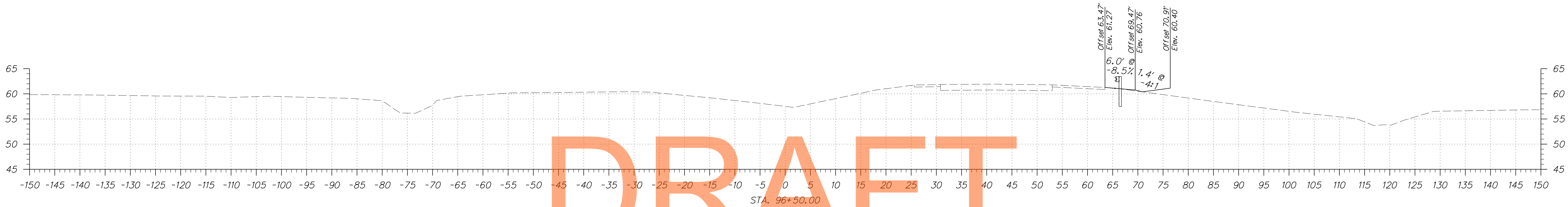

DRAFT

NOT FOR BIDDING

AUGUST 2015



ADDENDUMS / REVISIONS	

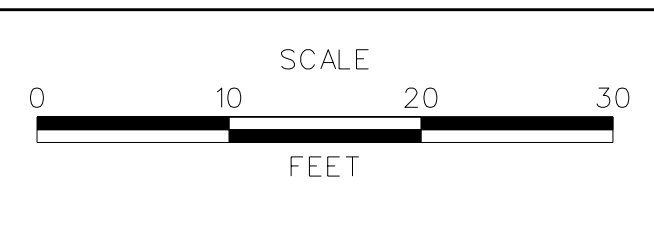

**US 301  
MARYLAND STATE LINE  
TO LEVELS ROAD**

CONTRACT T200811301	BRIDGE NO. 
COUNTY NEW CASTLE	DESIGNED BY: JEG
	CHECKED BY: MFM

<b>CROSS SECTIONS US 301 MAINLINE</b>	SHEET NO. 10
	TOTAL SHTS. 539

DRAFT

NOT FOR BIDDING

AUGUST 2015

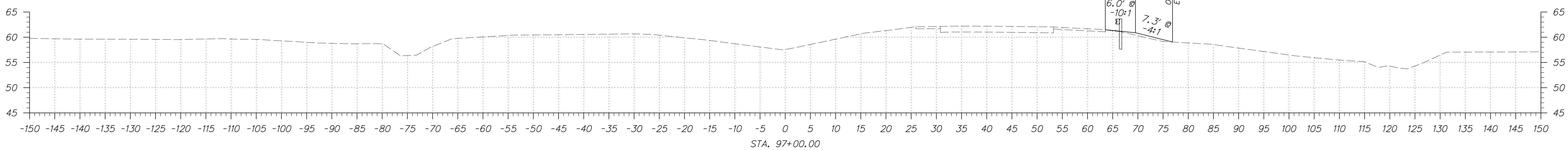
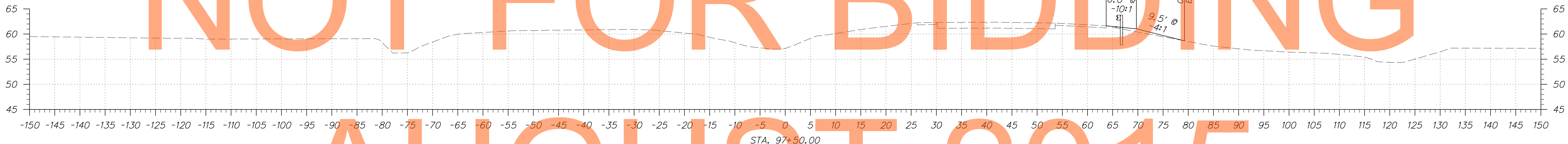
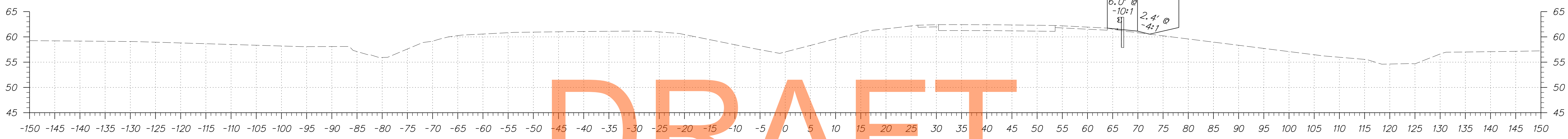

ADDENDUMS / REVISIONS	

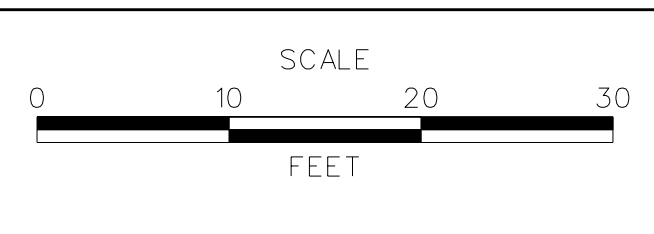

**US 301  
MARYLAND STATE LINE  
TO LEVELS ROAD**

CONTRACT T200811301	BRIDGE NO. 
COUNTY NEW CASTLE	DESIGNED BY: JEG
	CHECKED BY: MFM

<b>CROSS SECTIONS US 301 MAINLINE</b>	SHEET NO. 11
	TOTAL SHTS. 539

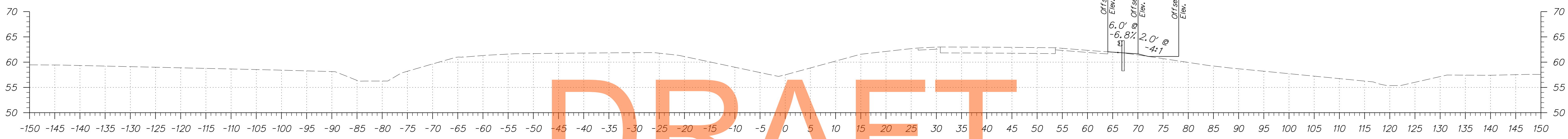

DRAFT

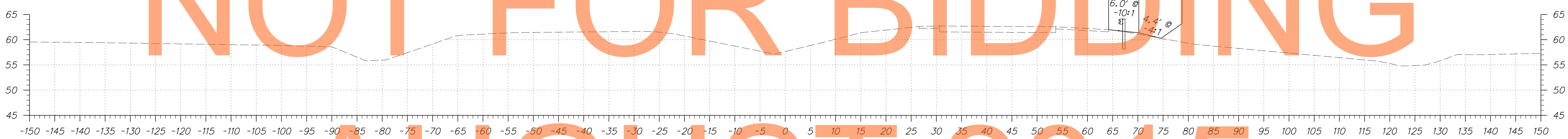

NOT FOR BIDDING

AUGUST 2015

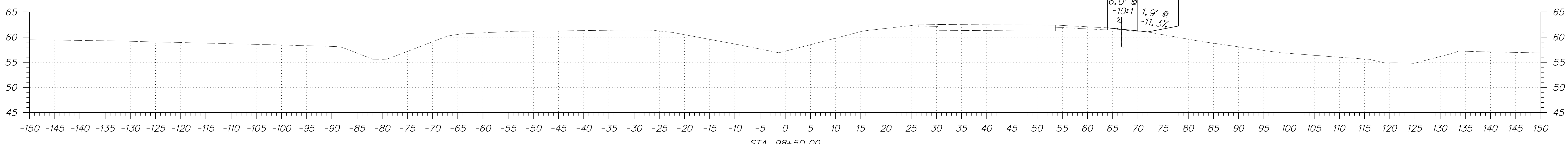

ADDENDUMS / REVISIONS	

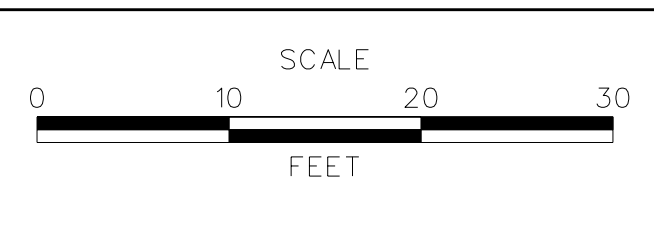

US 301  
MARYLAND STATE LINE  
TO LEVELS ROAD

CONTRACT T200811301	BRIDGE NO.
COUNTY NEW CASTLE	DESIGNED BY: JEG
	CHECKED BY: MFM

CROSS SECTIONS US 301 MAINLINE	SHEET NO. 12
	TOTAL SHTS. 539

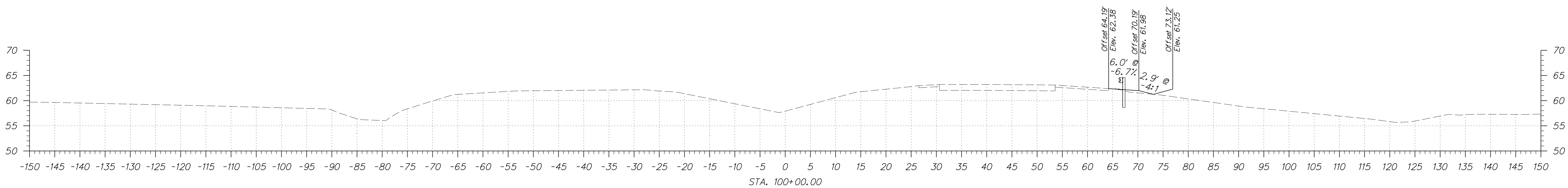
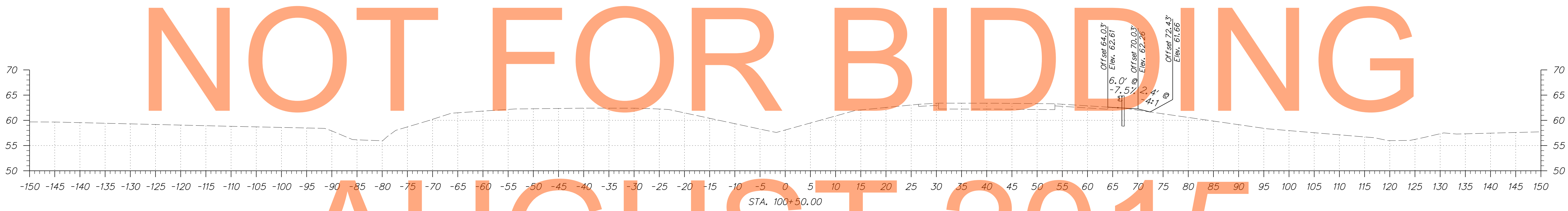
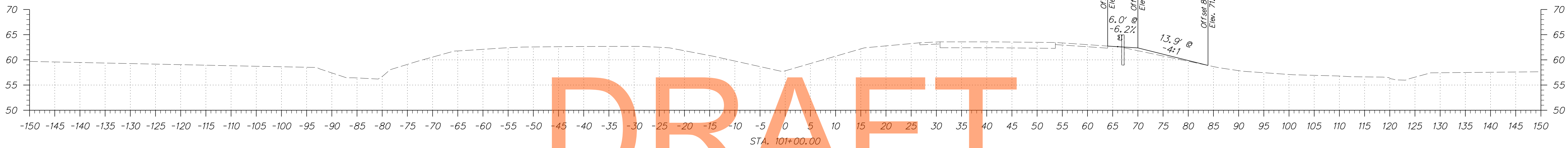

DRAFT

NOT FOR BIDDING

AUGUST 2015



ADDENDUMS / REVISIONS	

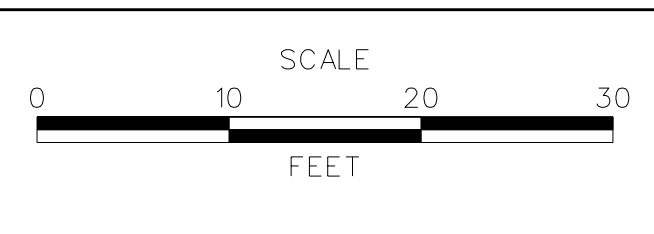

**US 301  
MARYLAND STATE LINE  
TO LEVELS ROAD**

CONTRACT T200811301	BRIDGE NO. 
COUNTY NEW CASTLE	DESIGNED BY: JEG
	CHECKED BY: MFM

<b>CROSS SECTIONS US 301 MAINLINE</b>	SHEET NO. 13
	TOTAL SHTS. 539

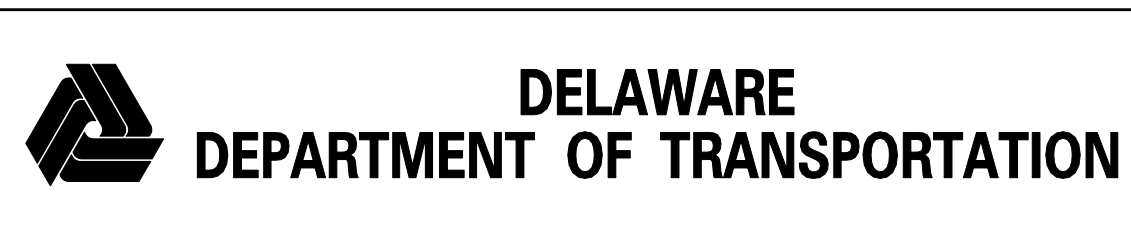
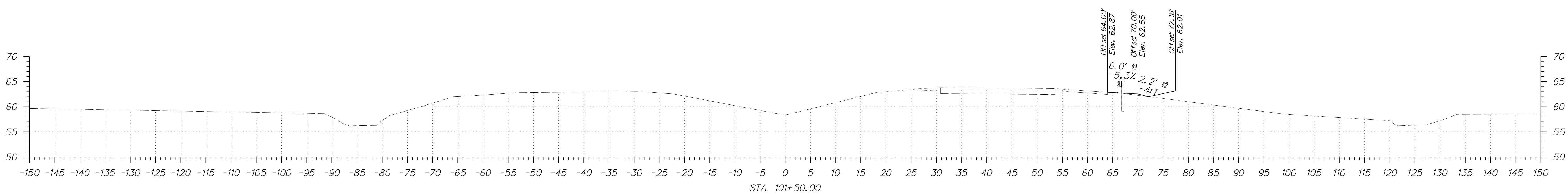
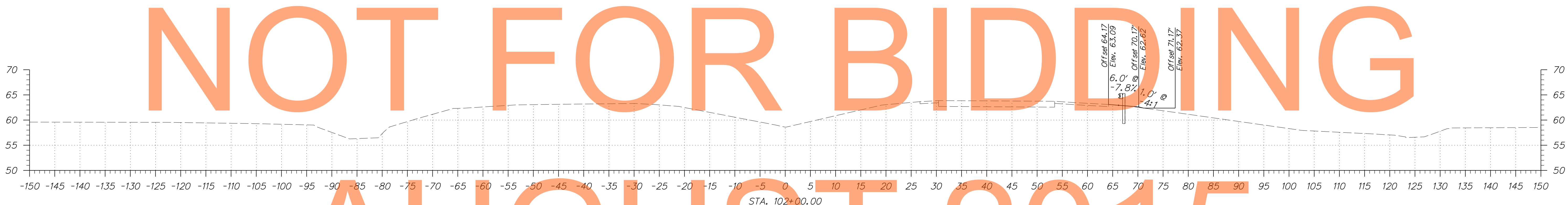
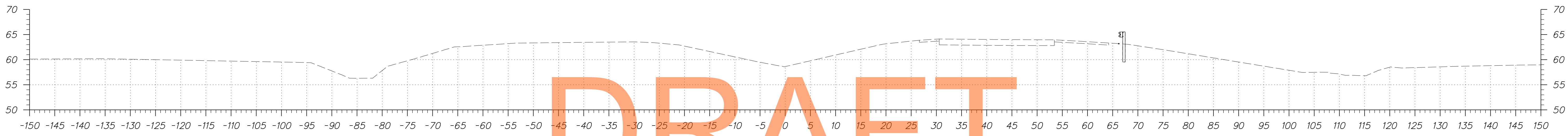

ADDENDUMS / REVISIONS	

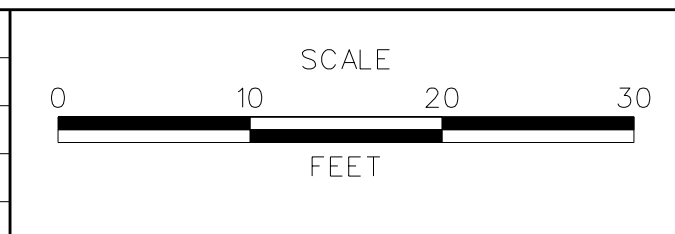

**US 301  
MARYLAND STATE LINE  
TO LEVELS ROAD**

CONTRACT T200811301	BRIDGE NO. 
COUNTY NEW CASTLE	DESIGNED BY: JEG
	CHECKED BY: MFM

<b>CROSS SECTIONS US 301 MAINLINE</b>	SHEET NO. 14
	TOTAL SHTS. 539

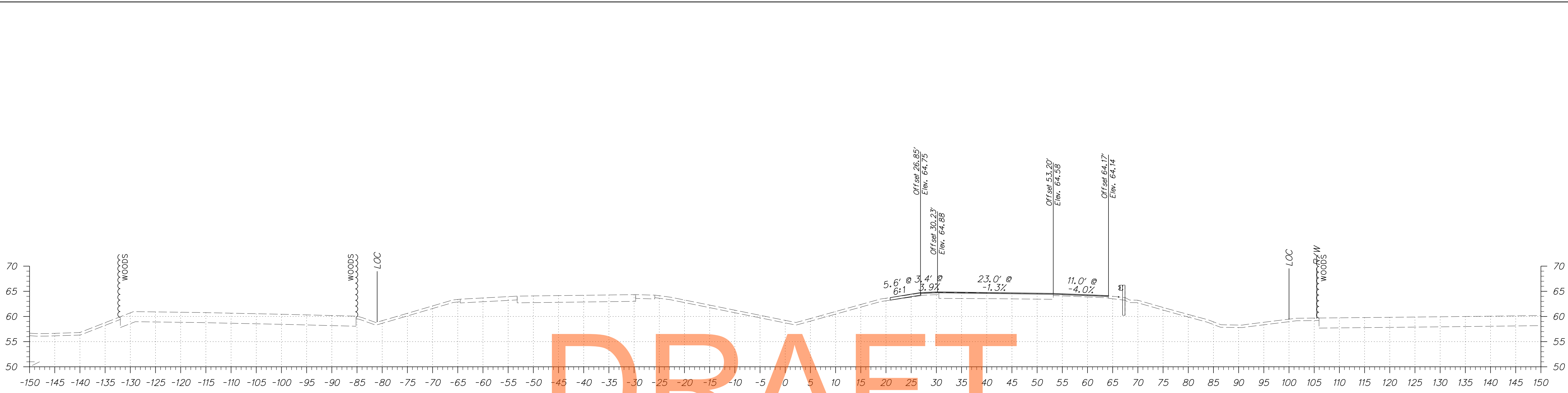

DRAFT

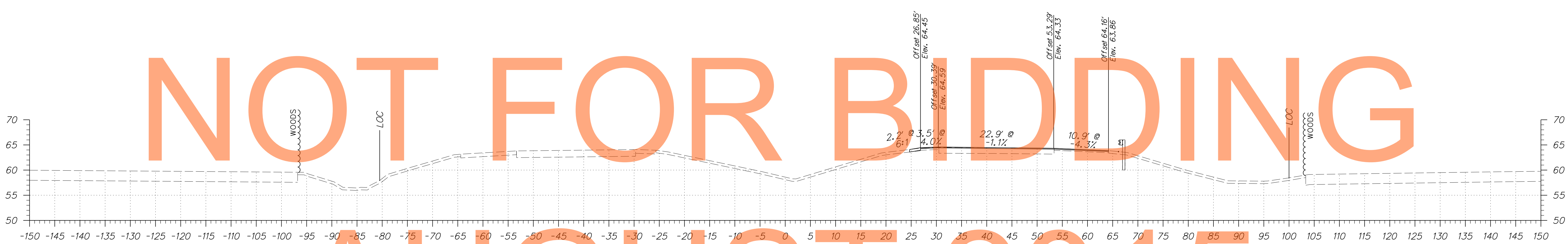

AUGUST 2015

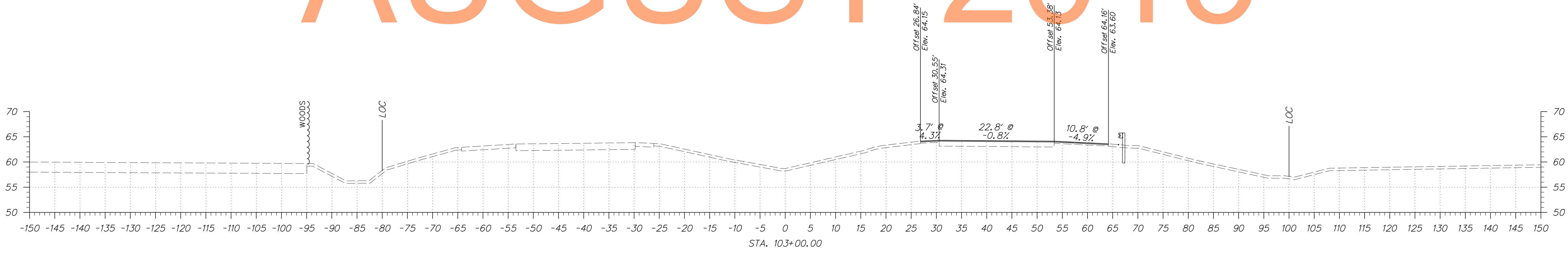

# DRAFT

# NOT FOR BIDDING

# AUGUST 2015

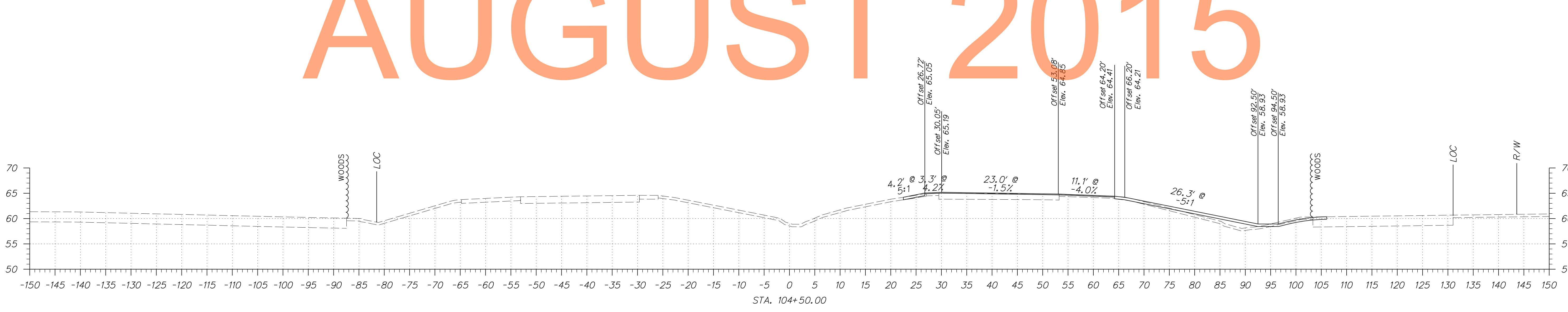
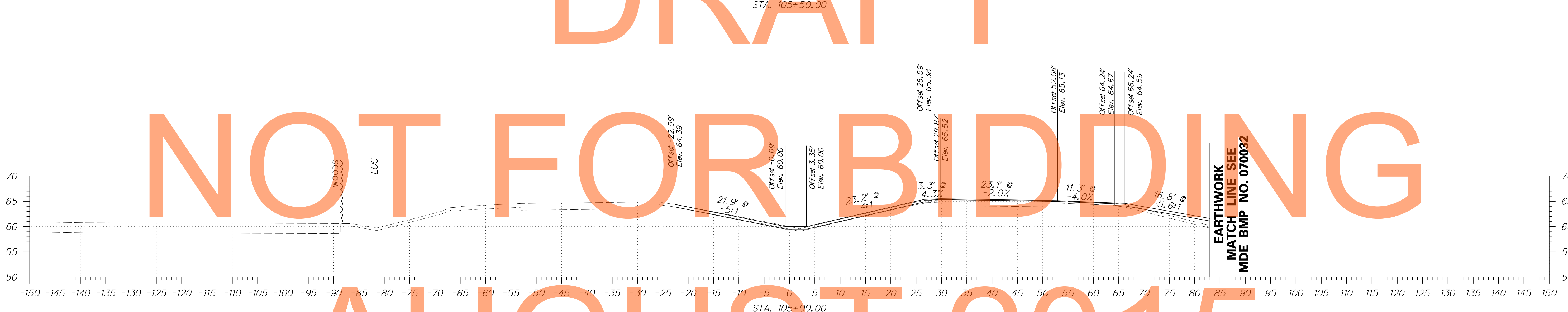
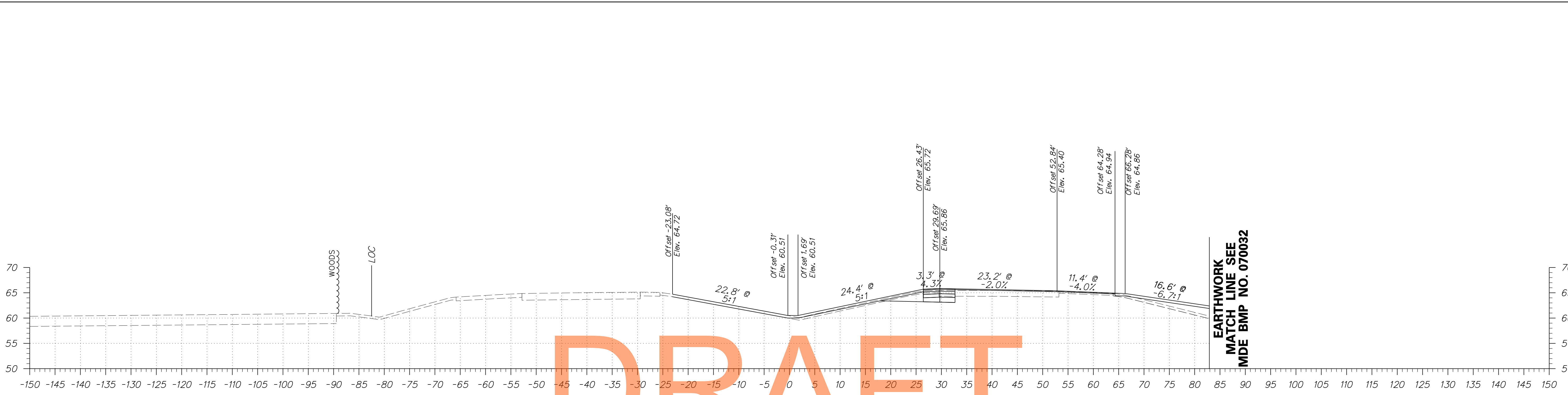

ADDENDUMS / REVISIONS	

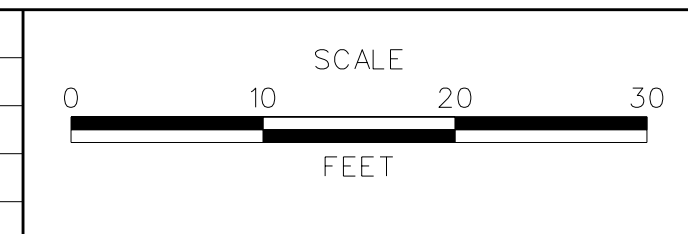

**US 301  
MARYLAND STATE LINE  
TO LEVELS ROAD**

CONTRACT T200811301	BRIDGE NO.
COUNTY NEW CASTLE	DESIGNED BY: JEG
	CHECKED BY: MFM

**CROSS SECTIONS  
US 301 MAINLINE**

SHEET NO. 16
TOTAL SHTS. 539



DRAFT

NOT FOR BIDDING

AUGUST 2015

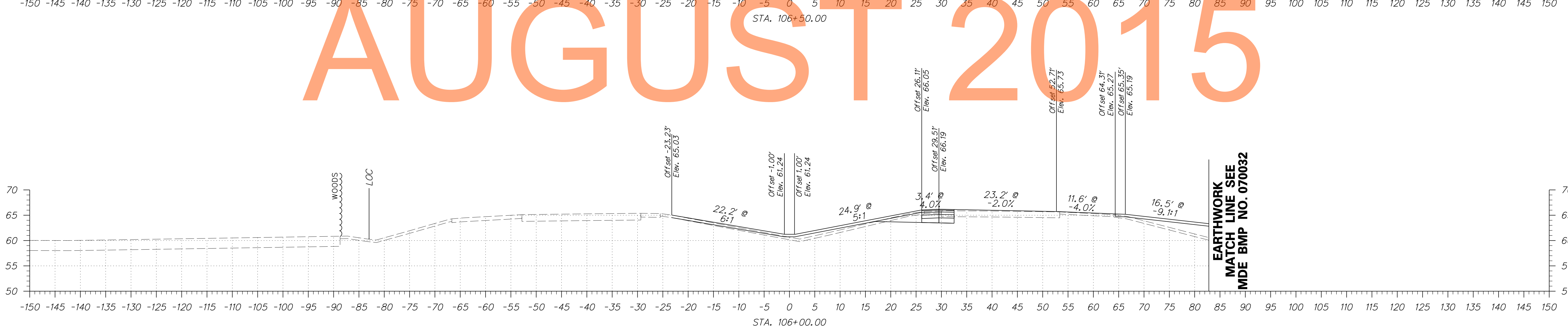
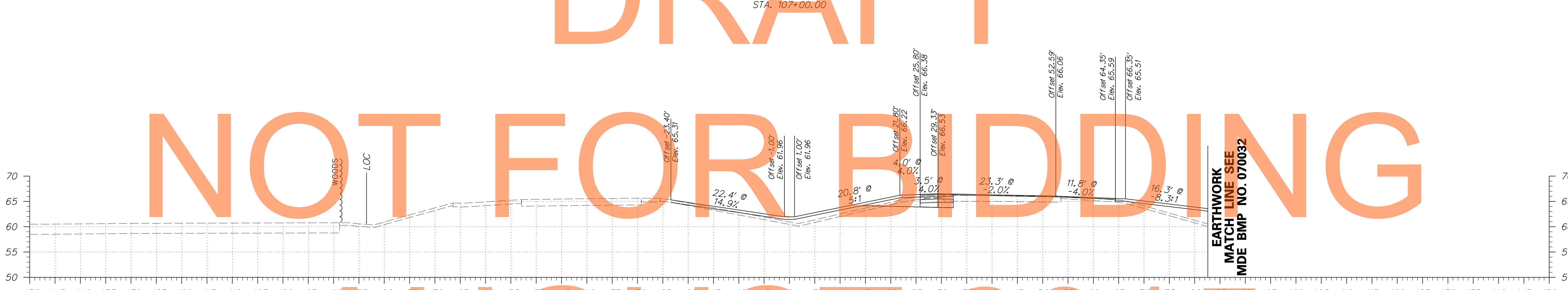
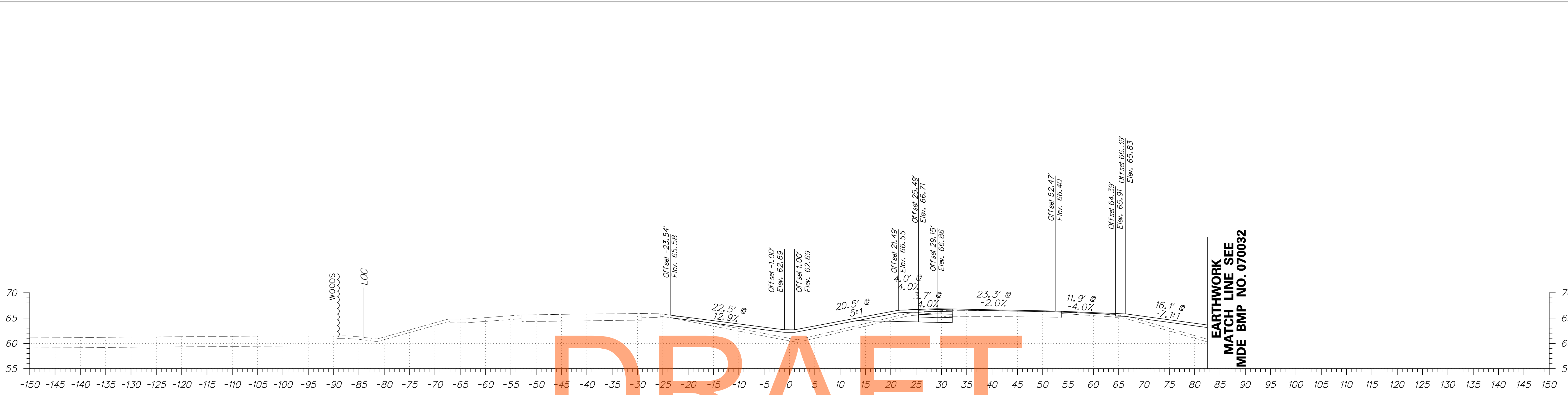

ADDENDUMS / REVISIONS

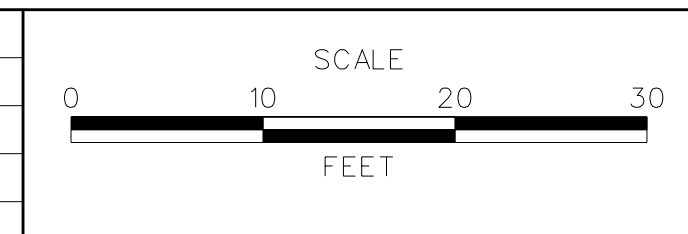

US 301  
MARYLAND STATE LINE  
TO LEVELS ROAD

CONTRACT T200811301	BRIDGE NO.
COUNTY NEW CASTLE	DESIGNED BY: JEG
	CHECKED BY: MFM

CROSS SECTIONS  
US 301 MAINLINE

SHEET NO. 17
TOTAL SHTS. 539

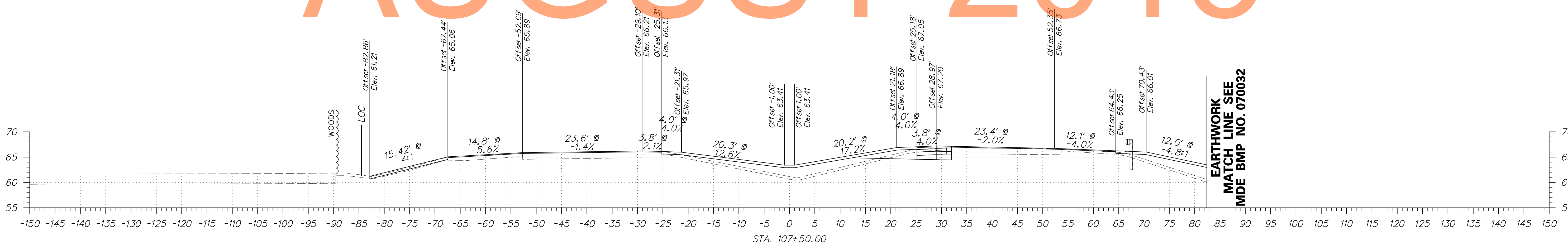
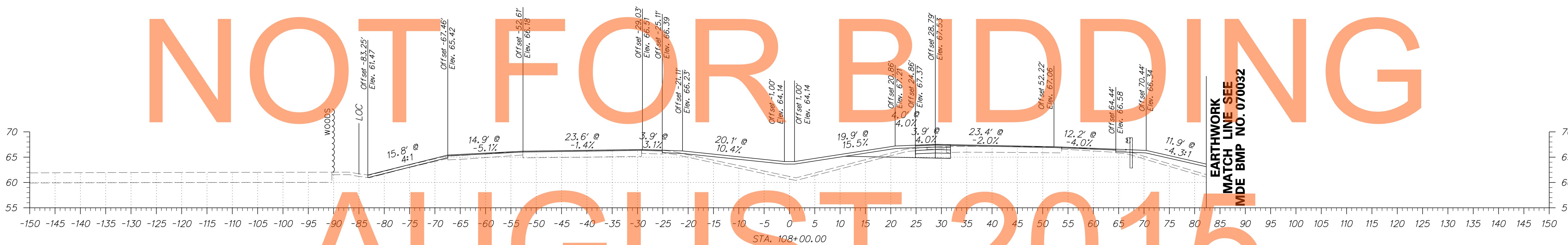
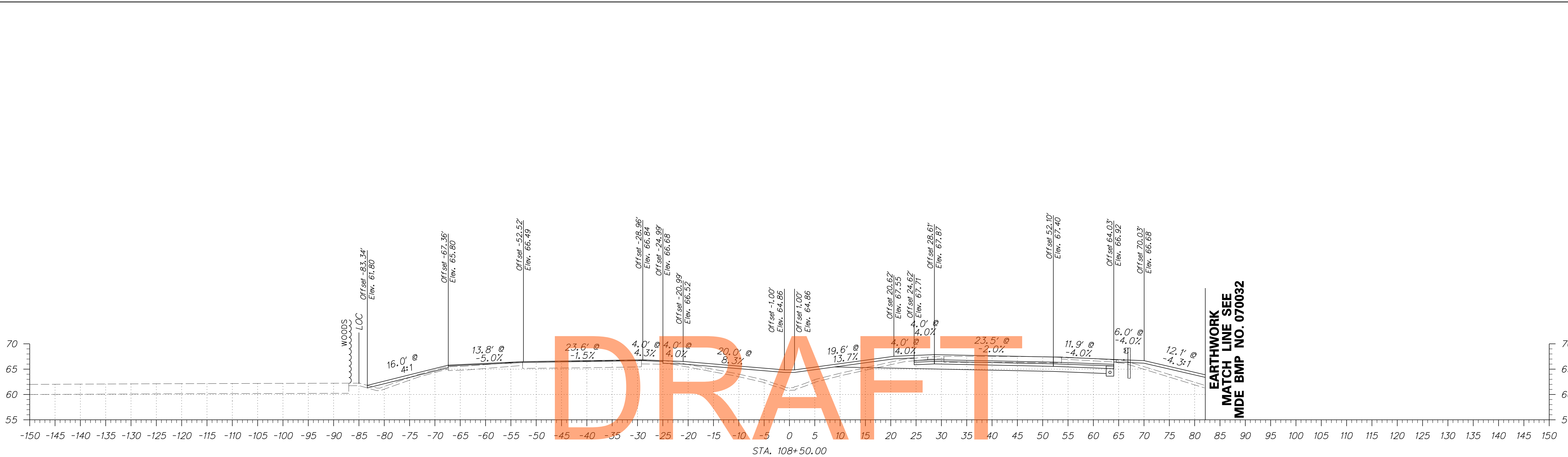

DRAFT

NOT FOR BIDDING

AUGUST 2015

ADDENDUMS / REVISIONS	

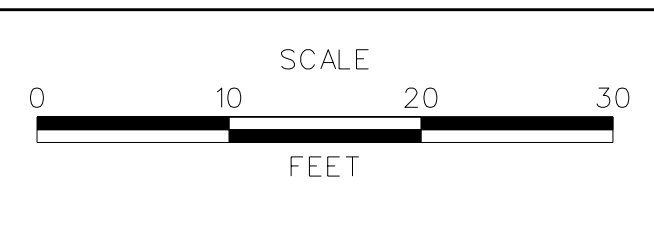

CONTRACT T200811301	BRIDGE NO.
COUNTY NEW CASTLE	DESIGNED BY: JEG
	CHECKED BY: MFM

# DRAFT

# NOT FOR BIDDING

# AUGUST 2015

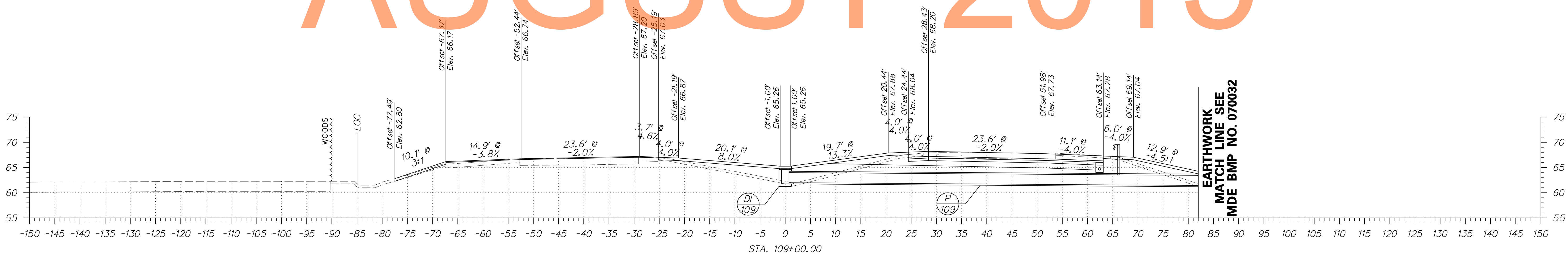
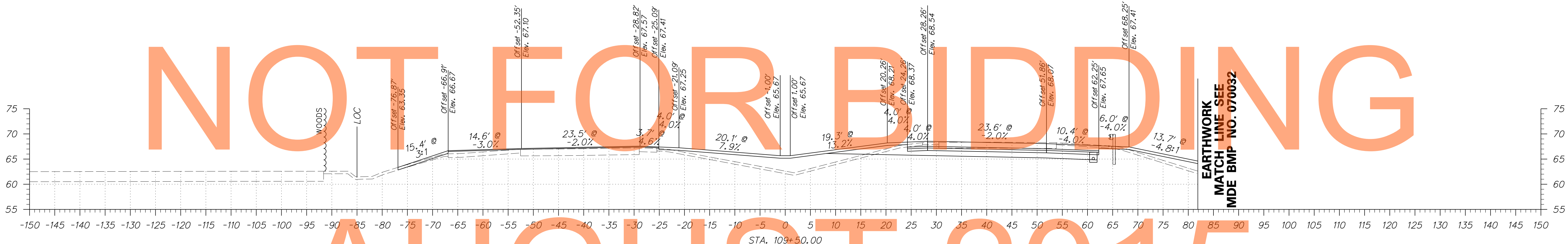
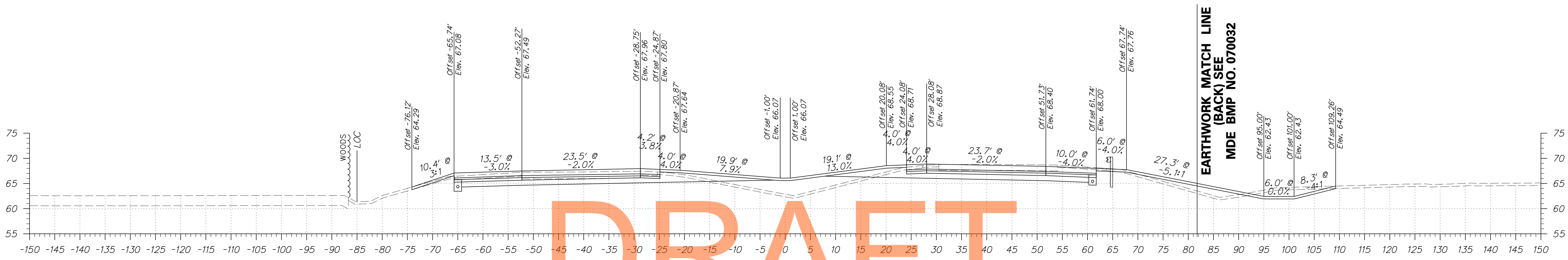

ADDENDUMS / REVISIONS

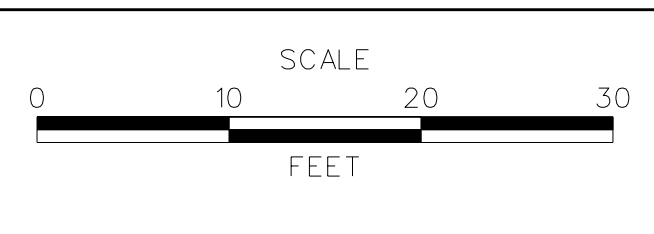

CONTRACT T200811301	BRIDGE NO.
COUNTY NEW CASTLE	DESIGNED BY: JEG
	CHECKED BY: MFM

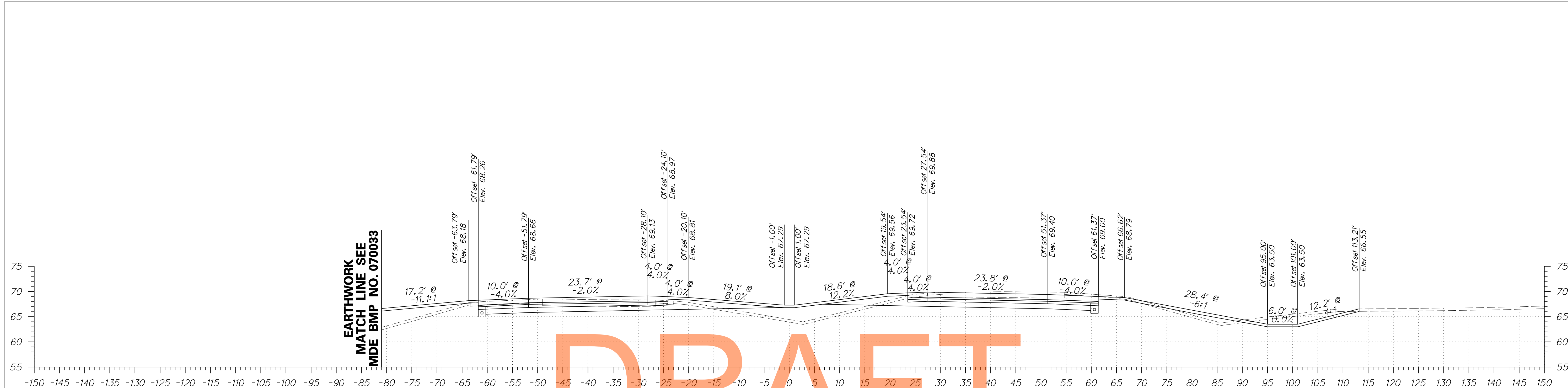

DRAFT

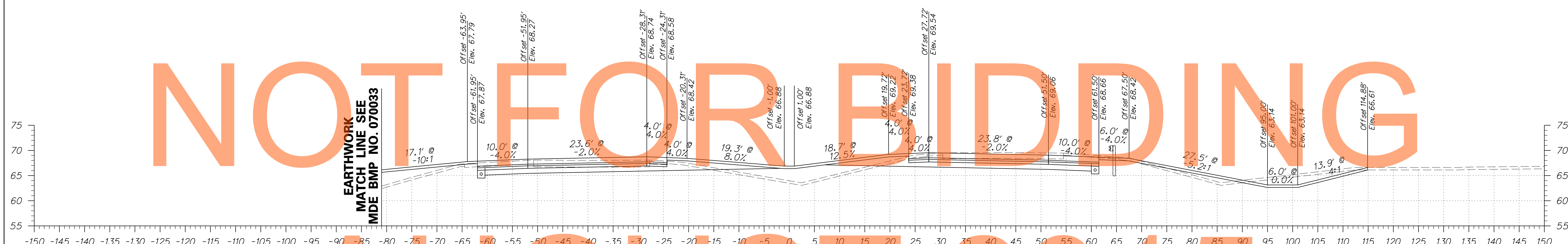

AUGUST 2015

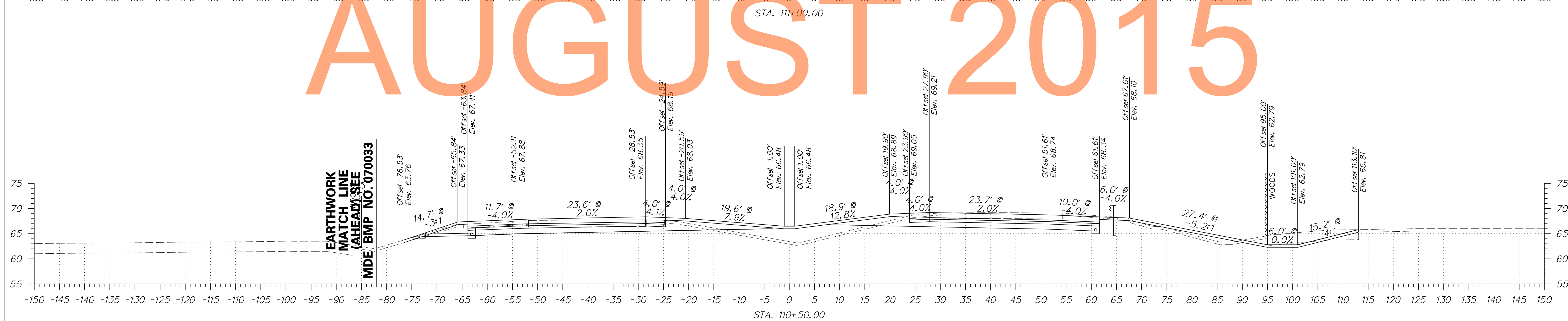

ADDENDUMS / REVISIONS	

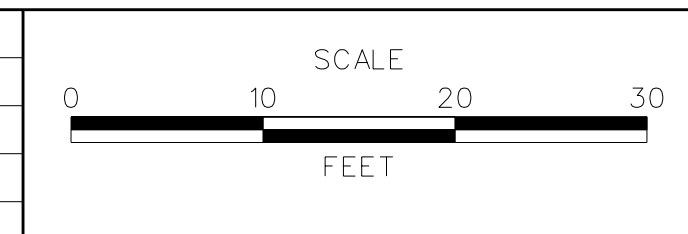

**US 301  
MARYLAND STATE LINE  
TO LEVELS ROAD**

CONTRACT T200811301	BRIDGE NO.
COUNTY NEW CASTLE	DESIGNED BY: JEG
	CHECKED BY: MFM

<b>CROSS SECTIONS US 301 MAINLINE</b>	SHEET NO. 20
	TOTAL SHTS. 539

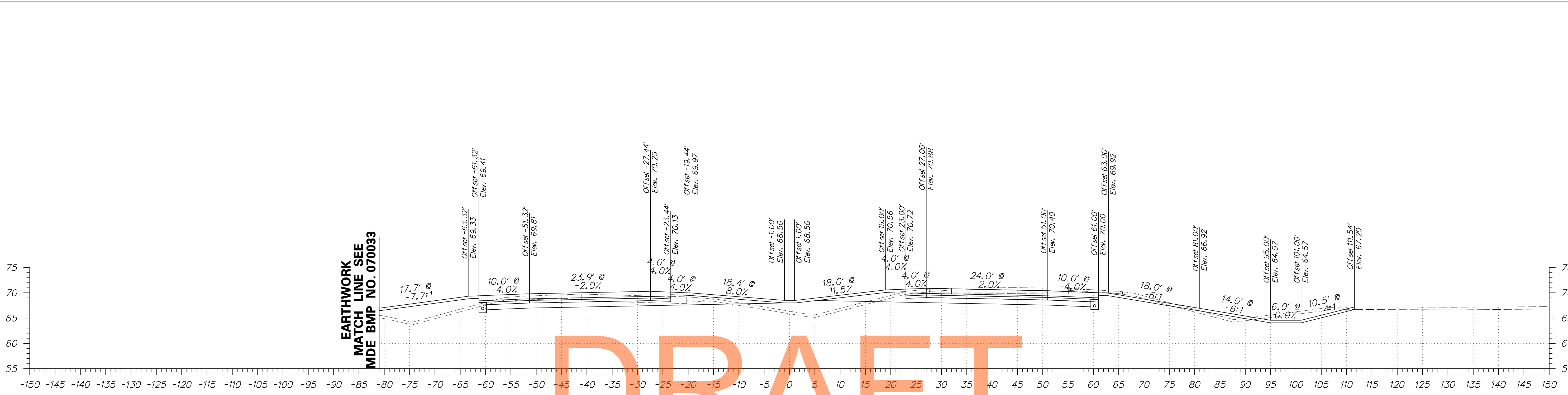

DRAFT

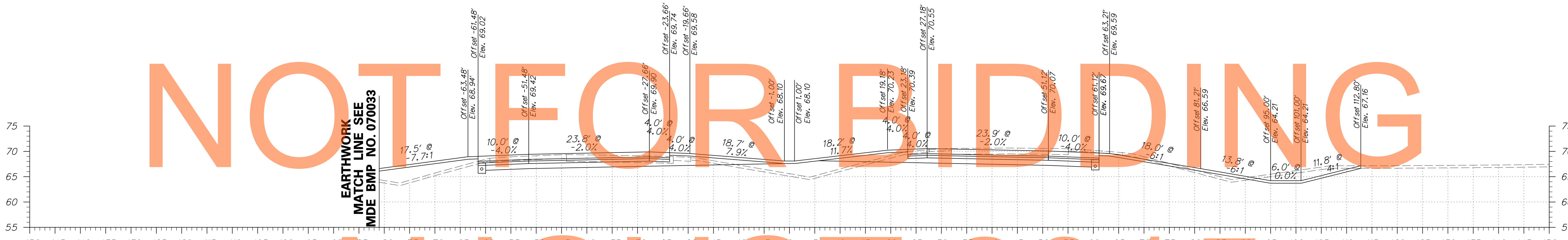

NOT FOR BIDDING

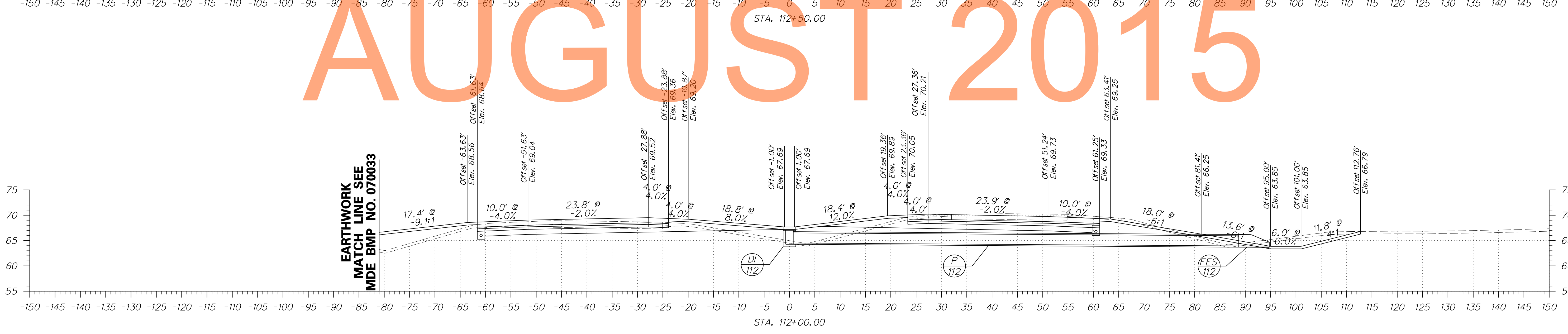

AUGUST 2015

ADDENDUMS / REVISIONS

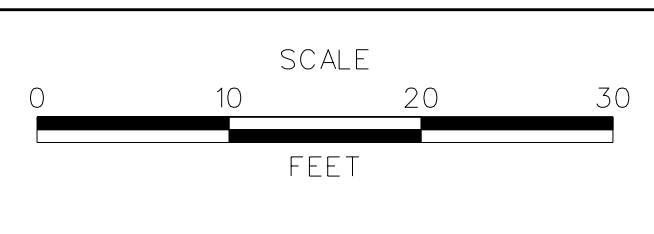

**US 301**  
**MARYLAND STATE LINE**  
**TO LEVELS ROAD**

CONTRACT T200811301	BRIDGE NO.
COUNTY NEW CASTLE	DESIGNED BY: JEG
	CHECKED BY: MFM

**CROSS SECTIONS**  
**US 301 MAINLINE**

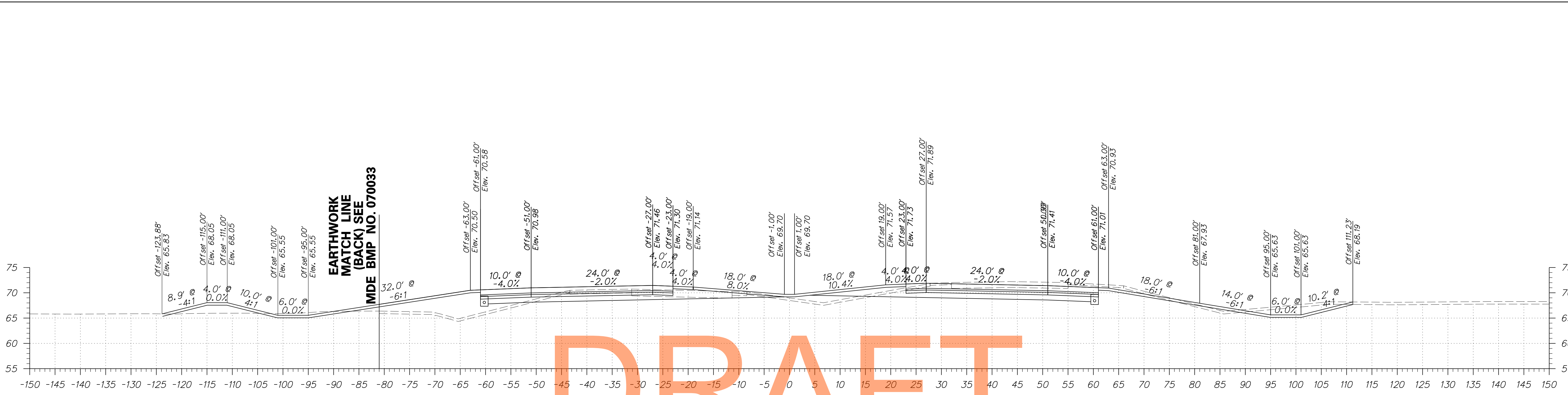

DRAFT

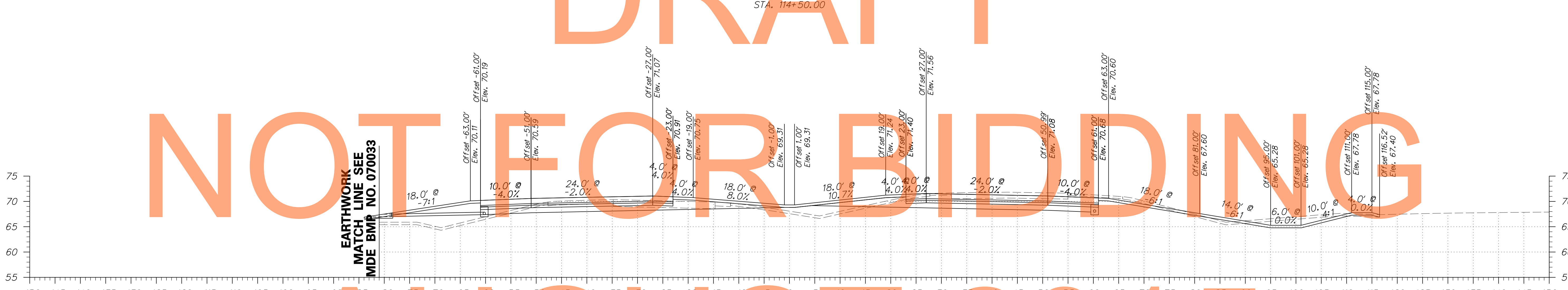

AUGUST 2015

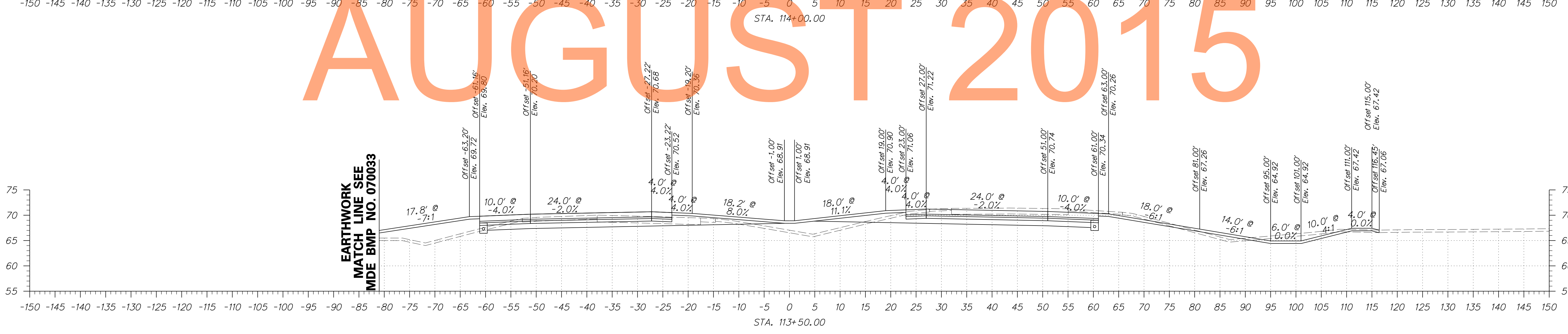

ADDENDUMS / REVISIONS	

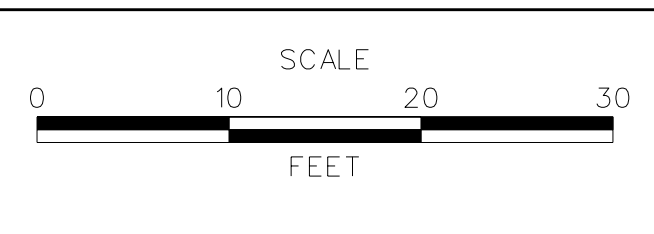

**US 301  
MARYLAND STATE LINE  
TO LEVELS ROAD**

CONTRACT T200811301	BRIDGE NO.
COUNTY NEW CASTLE	DESIGNED BY: JEG
	CHECKED BY: MFM

<b>CROSS SECTIONS US 301 MAINLINE</b>	SHEET NO. 22
	TOTAL SHTS. 539

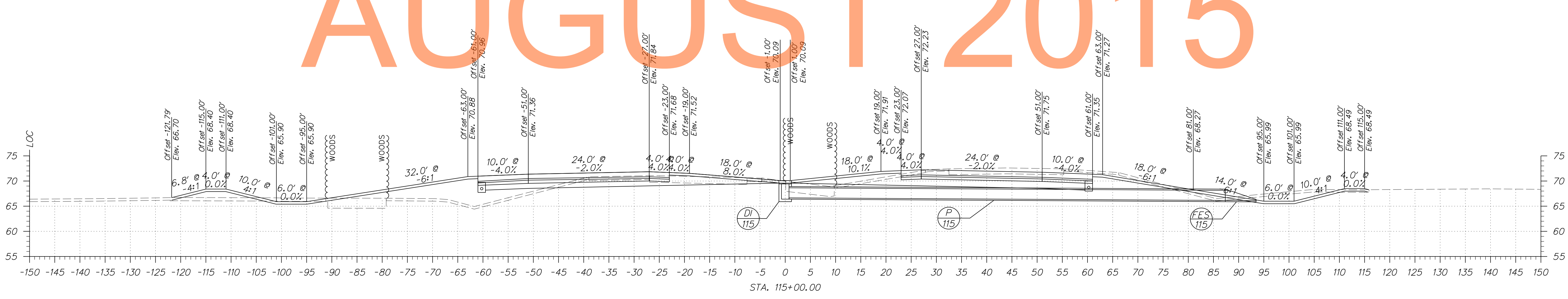
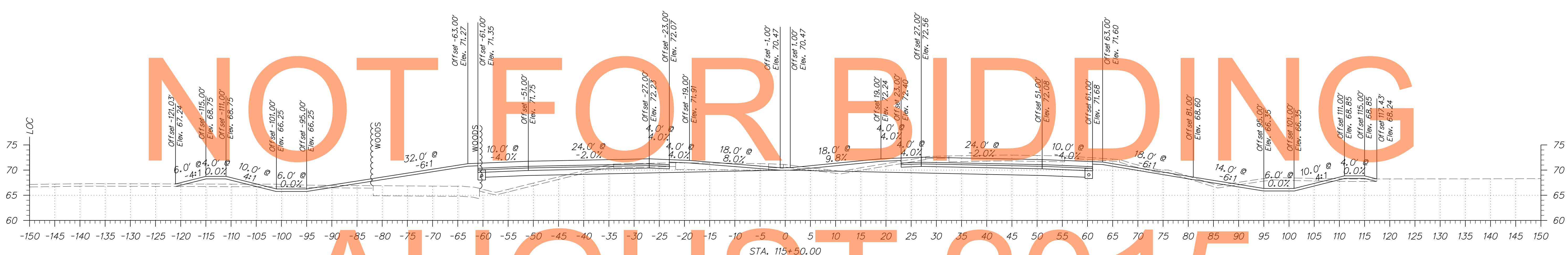
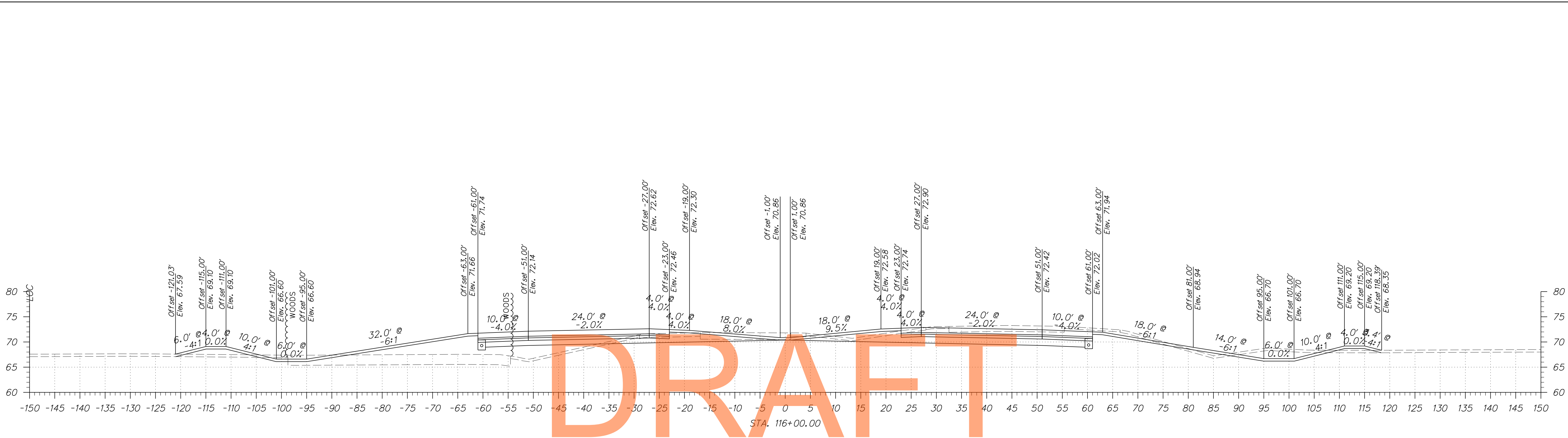

ADDENDUMS / REVISIONS

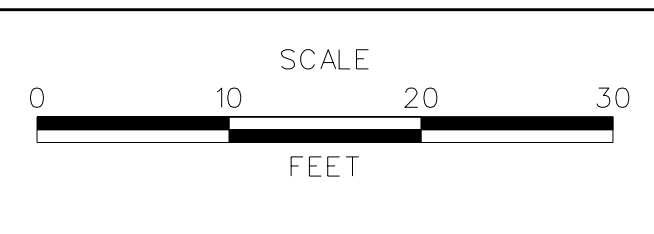

**US 301**  
**MARYLAND STATE LINE**  
**TO LEVELS ROAD**

CONTRACT T200811301	BRIDGE NO.
COUNTY NEW CASTLE	DESIGNED BY: JEG
	CHECKED BY: MFM

<b>CROSS SECTIONS</b> <b>US 301 MAINLINE</b>	SHEET NO. 23
	TOTAL SHTS. 539

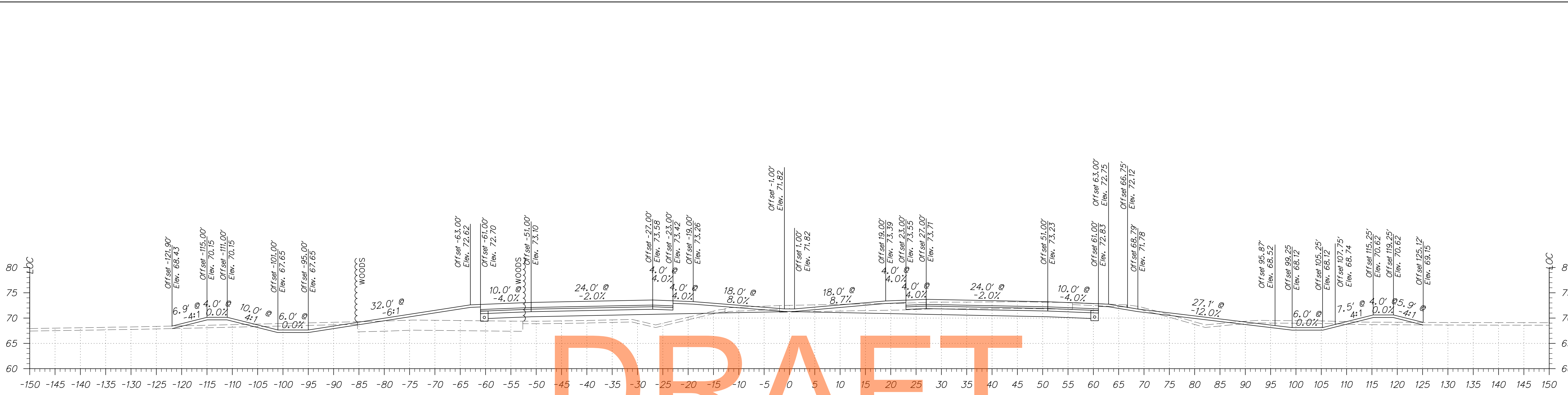

DRAFT

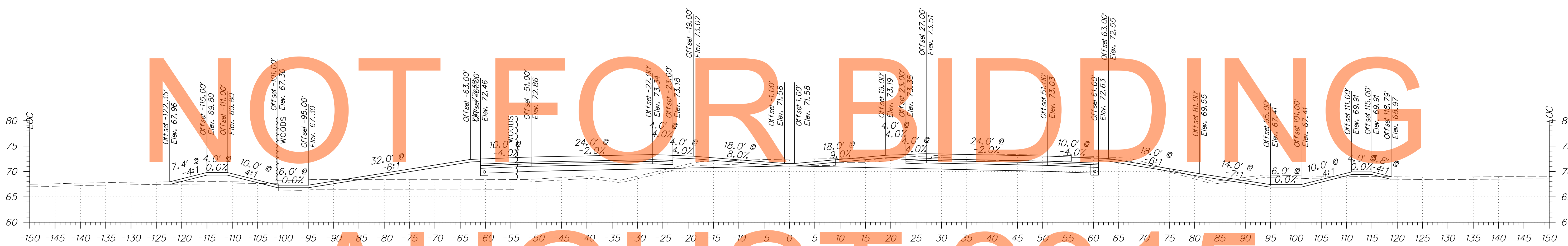

AUGUST 2015

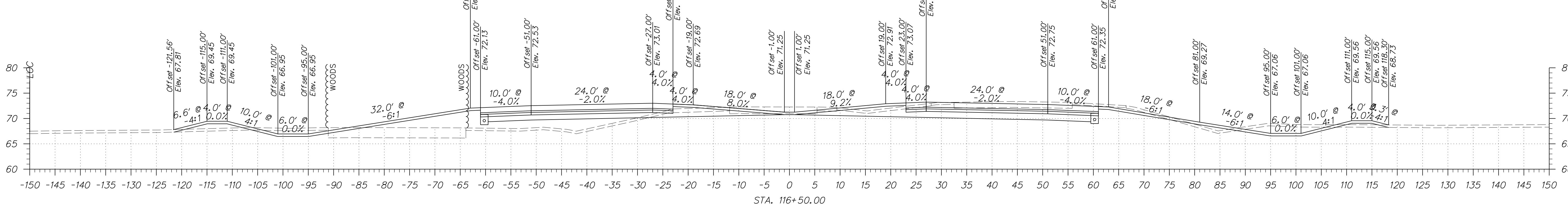

ADDENDUMS / REVISIONS	

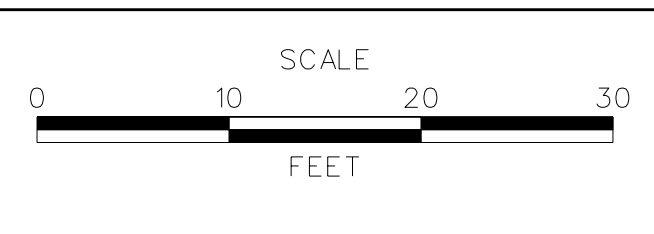

US 301  
MARYLAND STATE LINE  
TO LEVELS ROAD

CONTRACT T200811301	BRIDGE NO.
COUNTY NEW CASTLE	DESIGNED BY: JEG
	CHECKED BY: MFM

CROSS SECTIONS US 301 MAINLINE	SHEET NO. 24
	TOTAL SHTS. 539



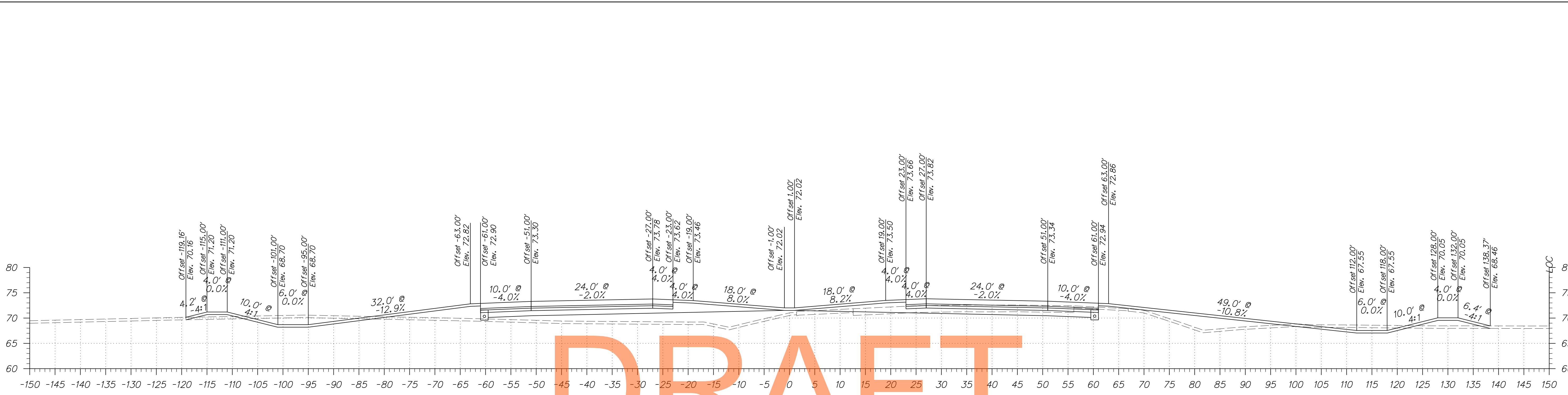

DRAFT

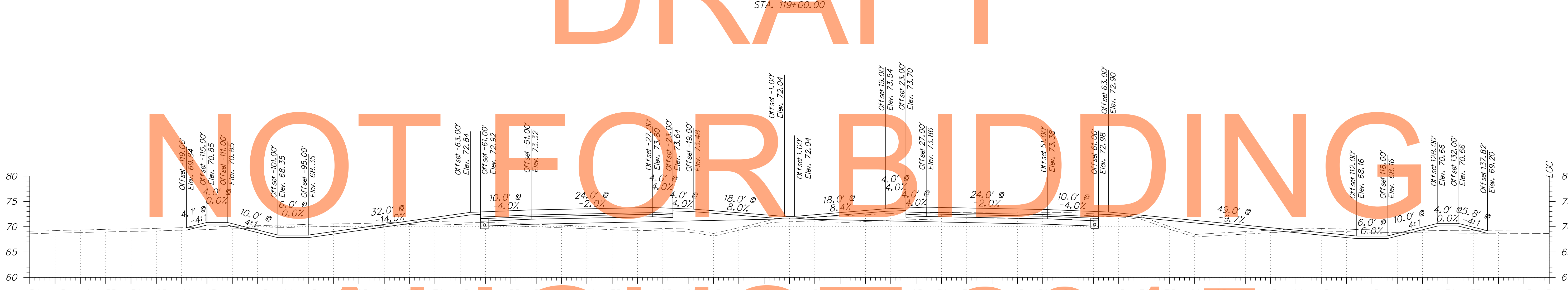

AUGUST 2015

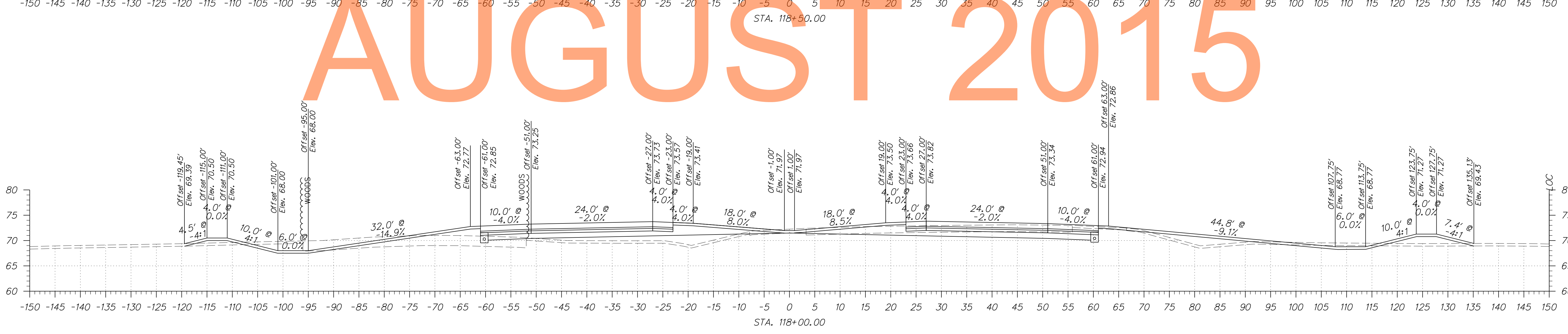

ADDENDUMS / REVISIONS	

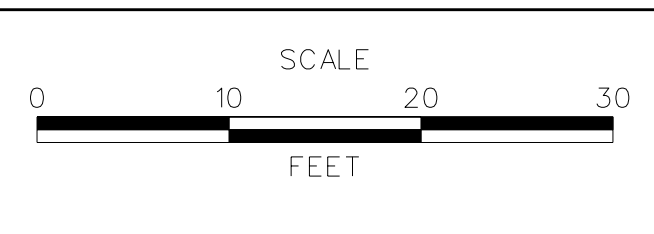

**US 301  
MARYLAND STATE LINE  
TO LEVELS ROAD**

CONTRACT T200811301	BRIDGE NO.
COUNTY NEW CASTLE	DESIGNED BY: JEG
	CHECKED BY: MFM

<b>CROSS SECTIONS US 301 MAINLINE</b>	SHEET NO. 25
	TOTAL SHTS. 539

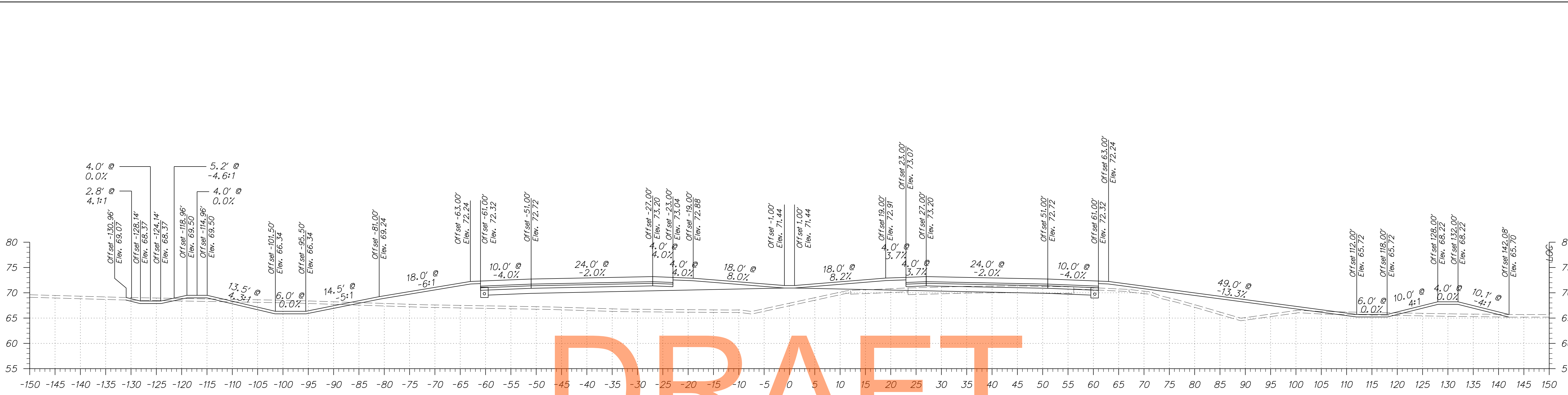

DRAFT

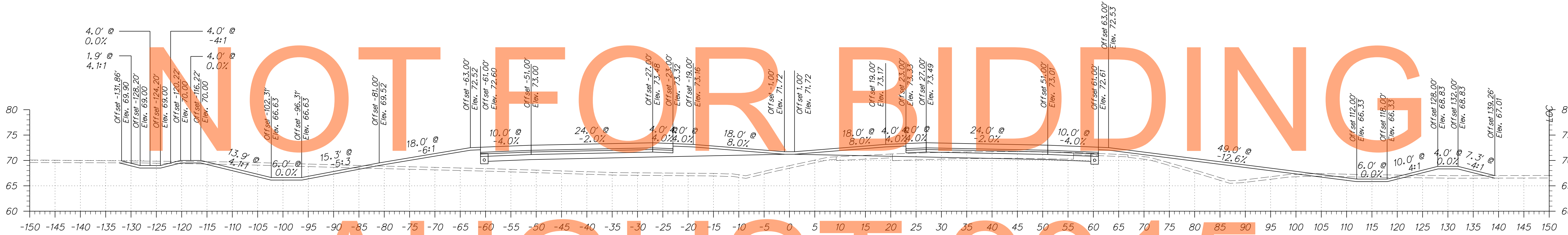

AUGUST 2015

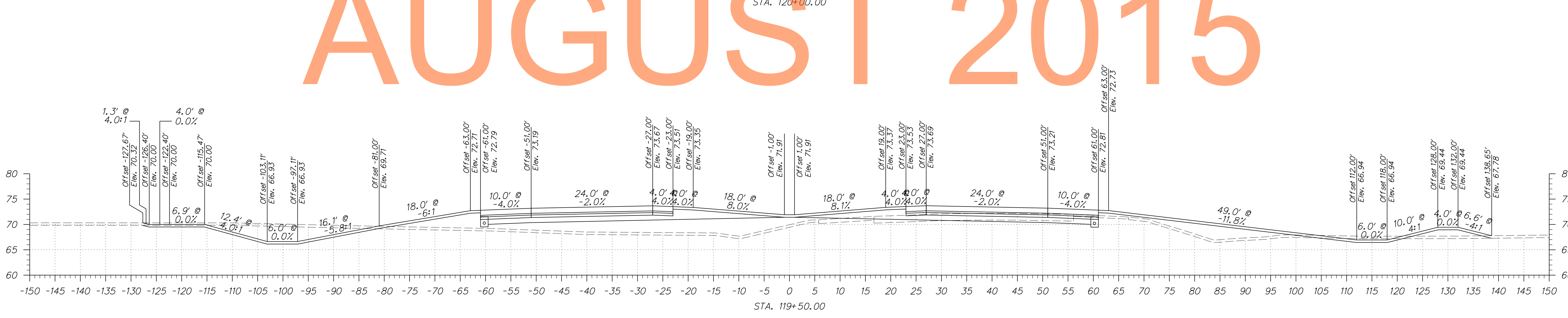

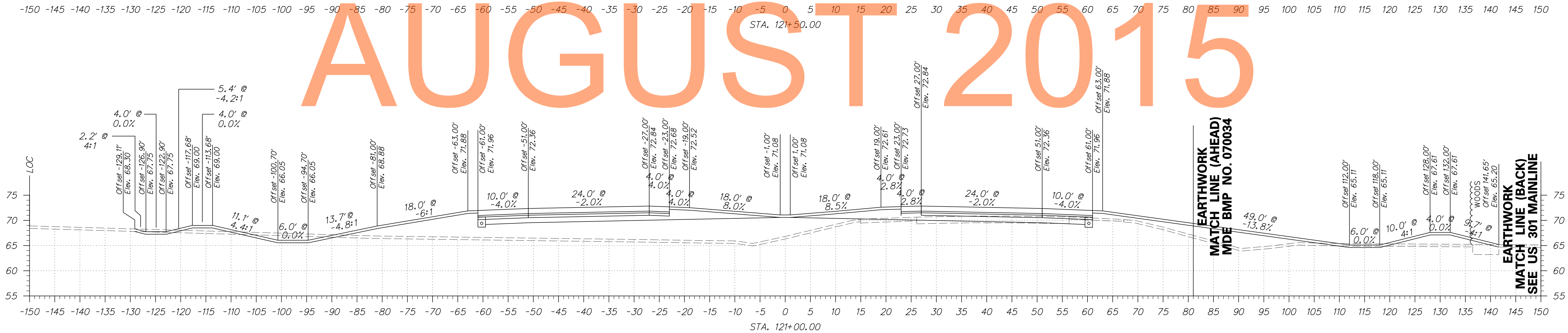
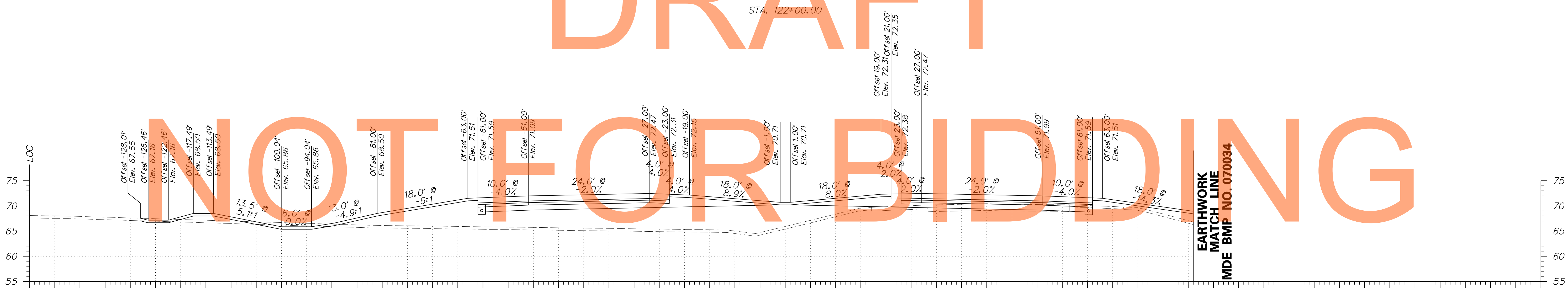
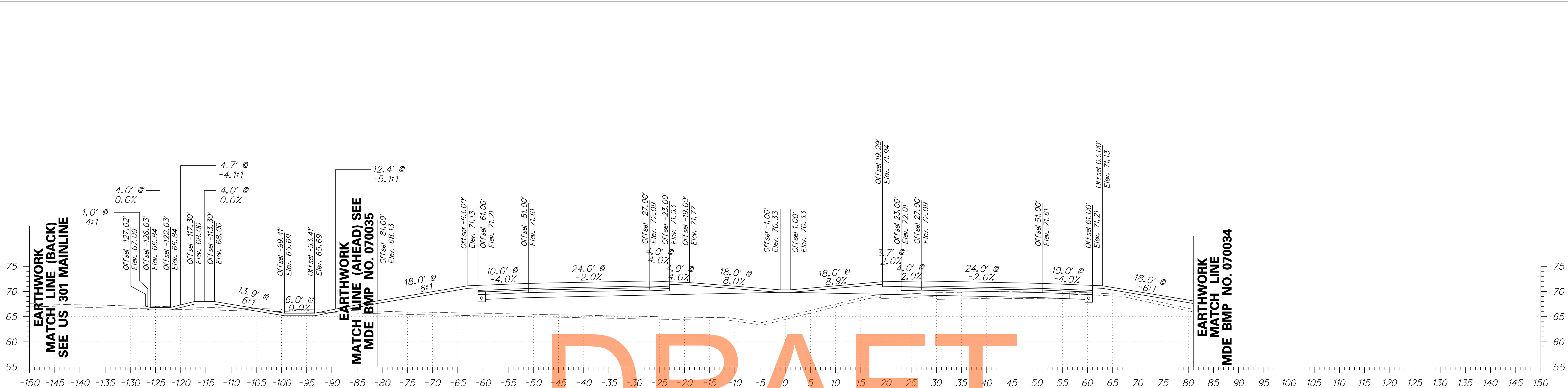

**DRAFT**

**NOT FOR BIDDING**

**AUGUST 2015**

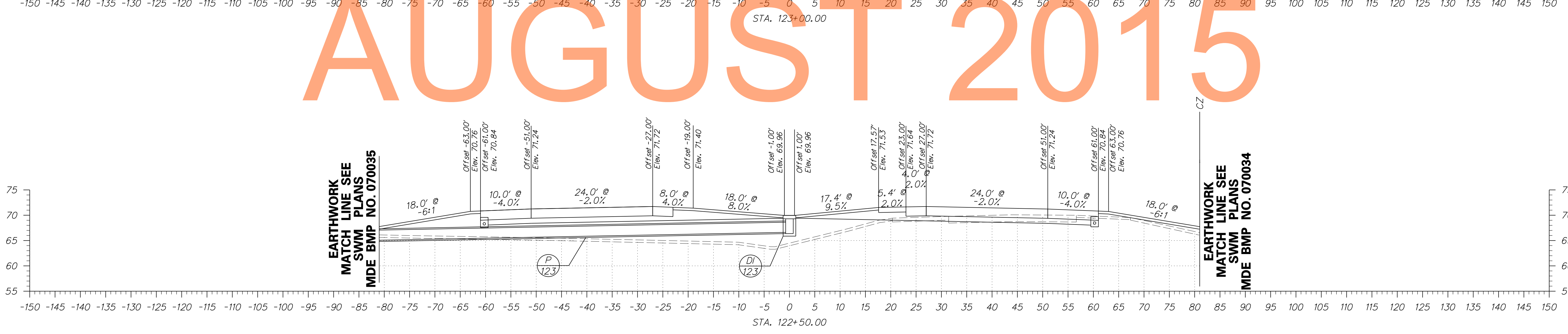
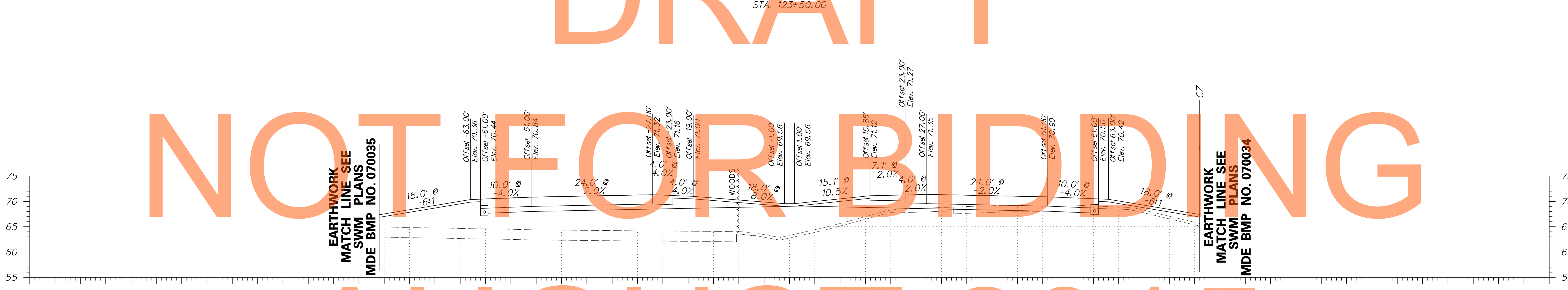
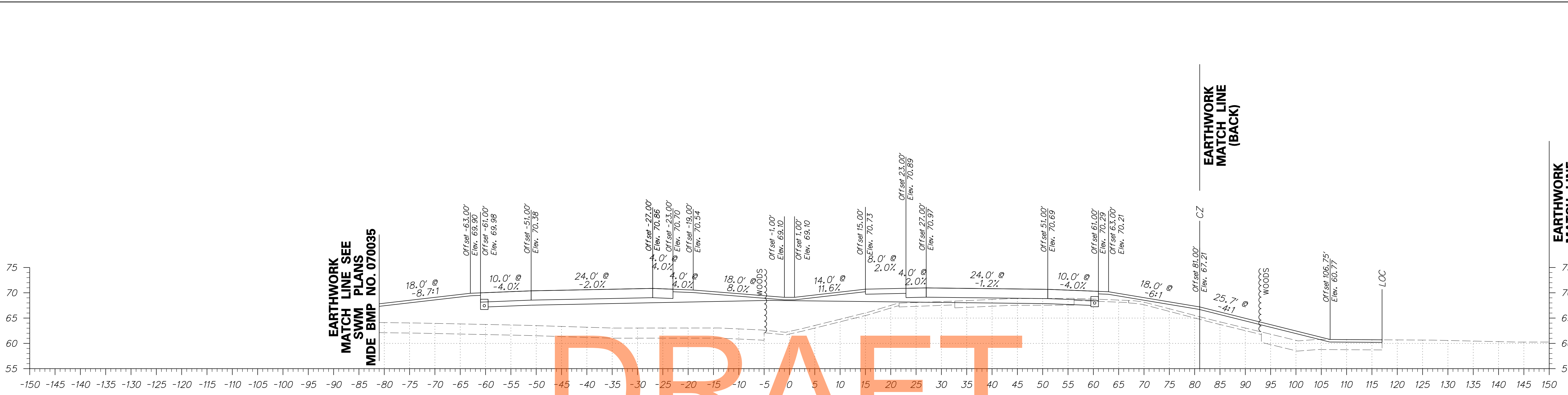

ADDENDUMS / REVISIONS	

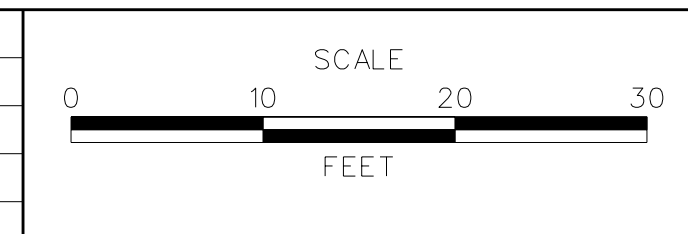

**US 301**  
**MARYLAND STATE LINE**  
**TO LEVELS ROAD**

CONTRACT T200811301	BRIDGE NO. 
COUNTY NEW CASTLE	DESIGNED BY: JEG CHECKED BY: MFM

**CROSS SECTIONS**  
**US 301 MAINLINE**

SHEET NO. 28
TOTAL SHTS. 539

EARTHWORK  
MATCH LINE (AHEAD)

EARTHWORK  
MATCH LINE (BACK)  
SWM PLANS  
MDE BMP NO. 070035

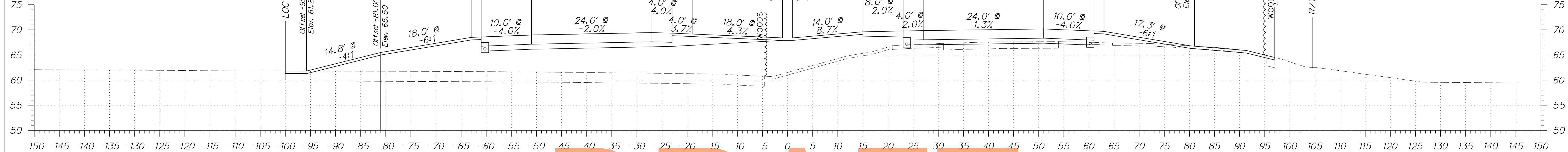

DRAFT

NOT FOR BIDDING

EARTHWORK  
MATCH LINE SEE  
SWM PLANS  
MDE BMP NO. 070035

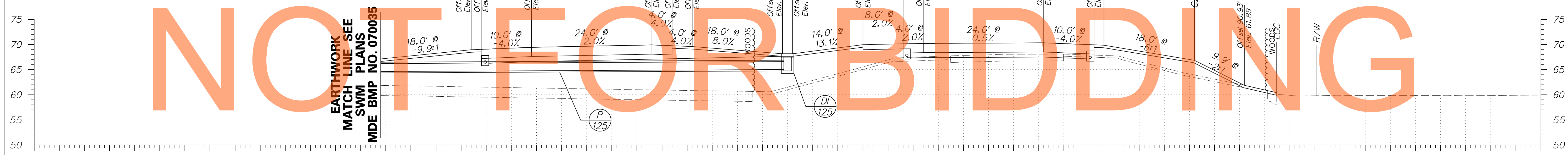

AUGUST 2015

EARTHWORK  
MATCH LINE SEE  
SWM PLANS  
MDE BMP NO. 070035

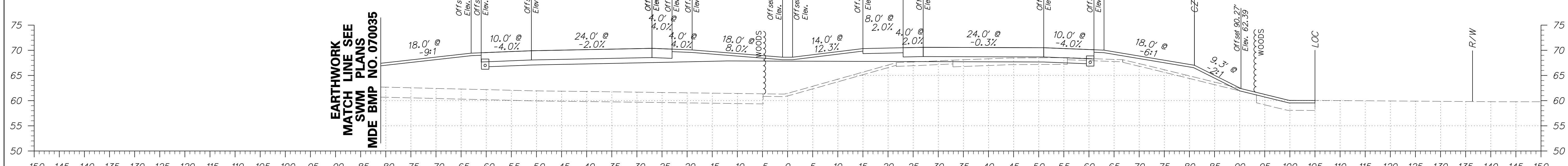

ADDENDUMS / REVISIONS	

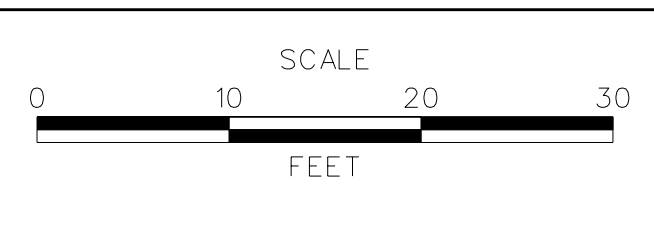

US 301  
MARYLAND STATE LINE  
TO LEVELS ROAD

CONTRACT T200811301	BRIDGE NO.
COUNTY NEW CASTLE	DESIGNED BY: JEG
	CHECKED BY: MFM

CROSS SECTIONS US 301 MAINLINE	SHEET NO. 29
	TOTAL SHTS. 539

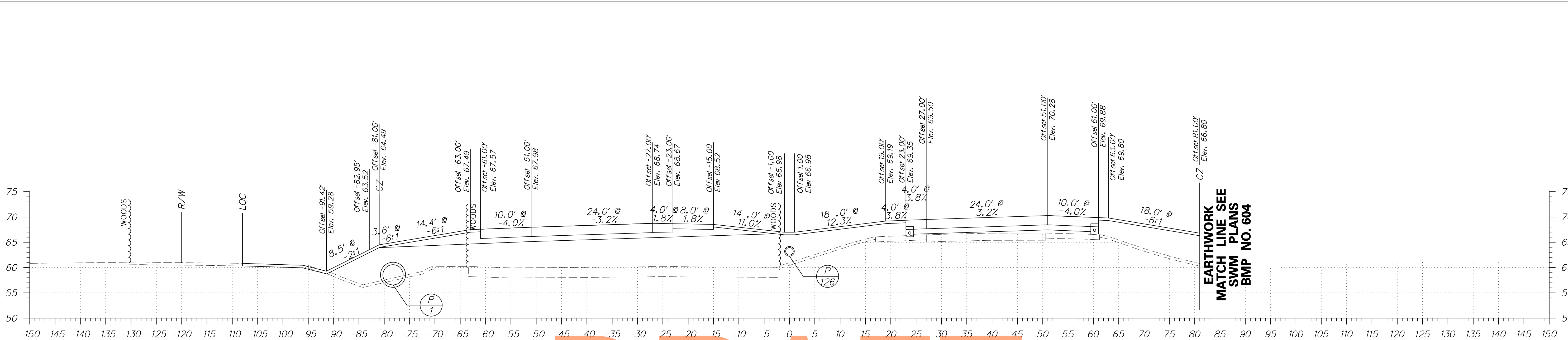

DRAFT

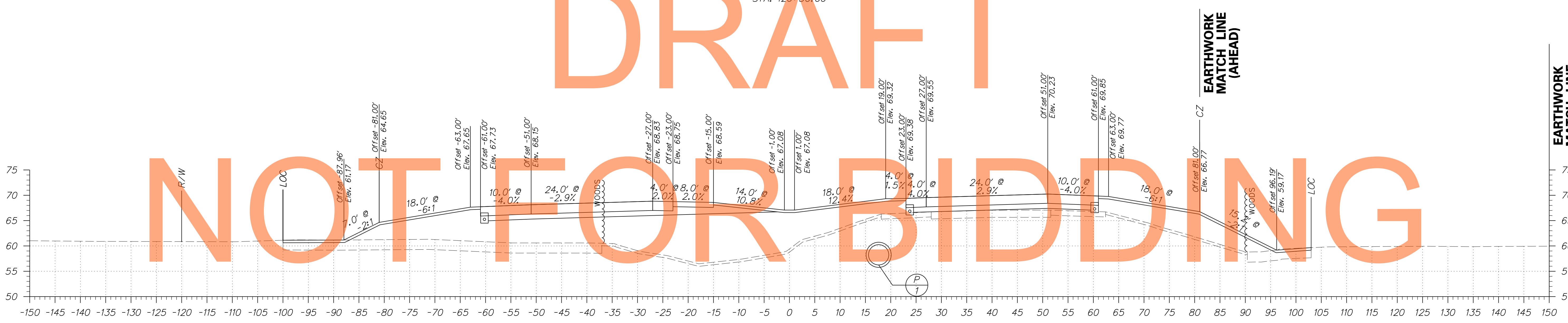

AUGUST 2015

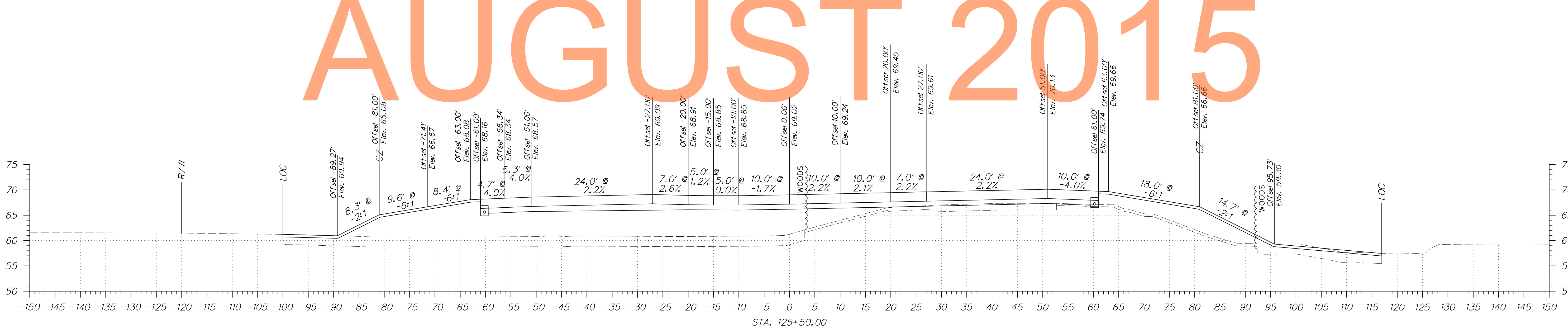

ADDENDUMS / REVISIONS	

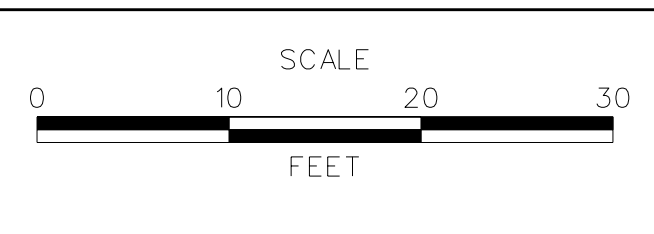

**US 301  
MARYLAND STATE LINE  
TO LEVELS ROAD**

CONTRACT T200811301	BRIDGE NO.
COUNTY NEW CASTLE	DESIGNED BY: JEG
	CHECKED BY: MFM

<b>CROSS SECTIONS US 301 MAINLINE</b>	
SHEET NO.	30
TOTAL SHTS.	539

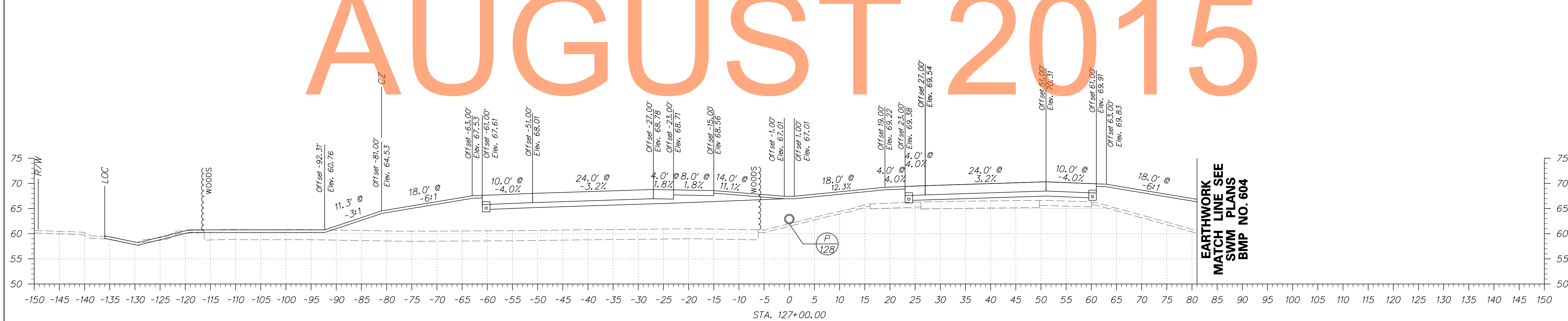
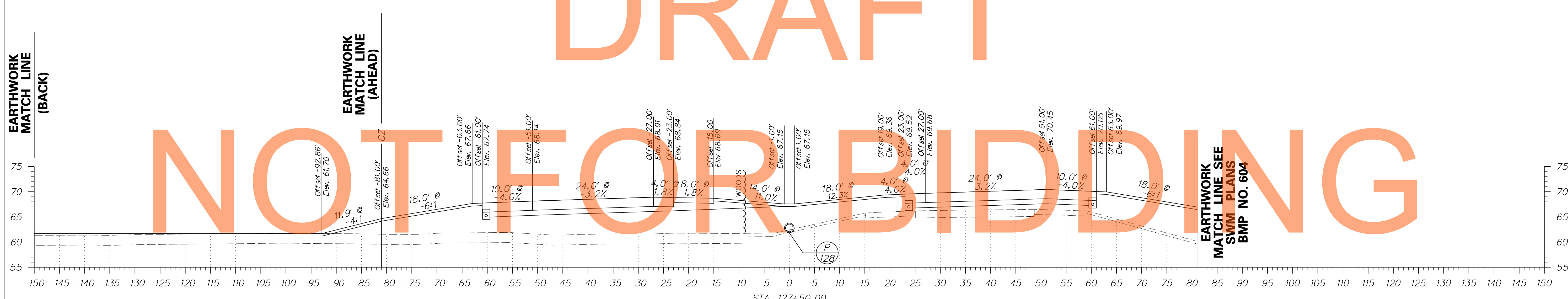
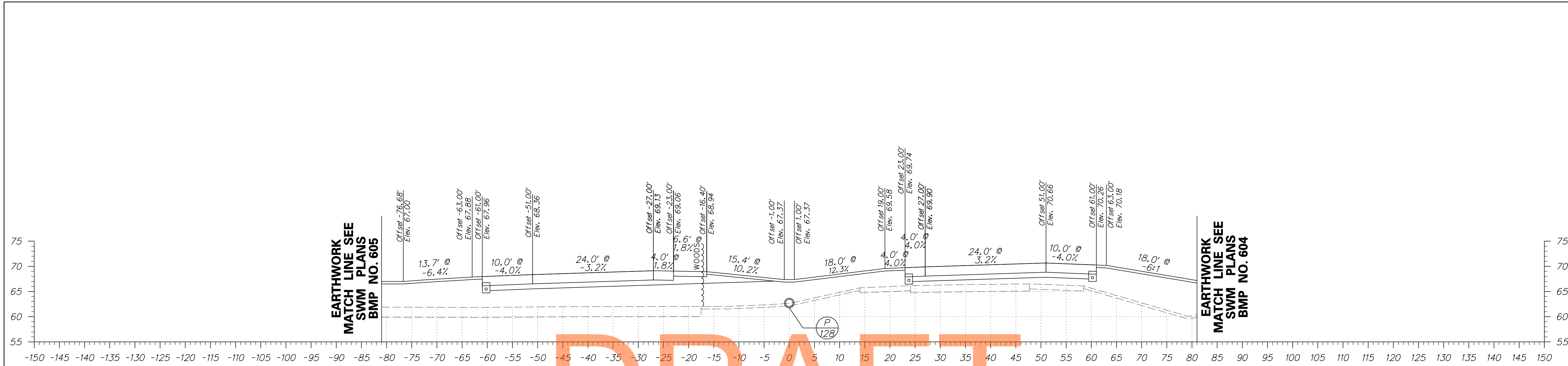

DRAFT

NOT FOR BIDDING

AUGUST 2015

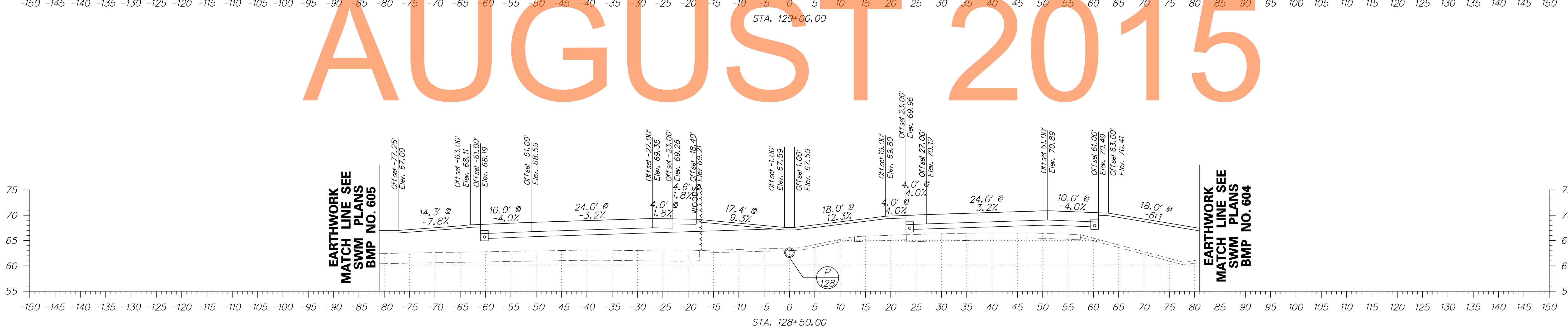
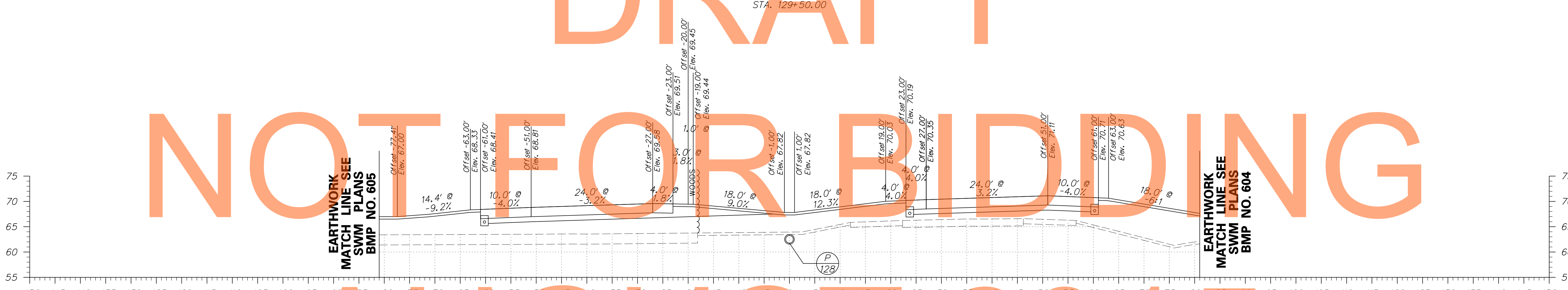
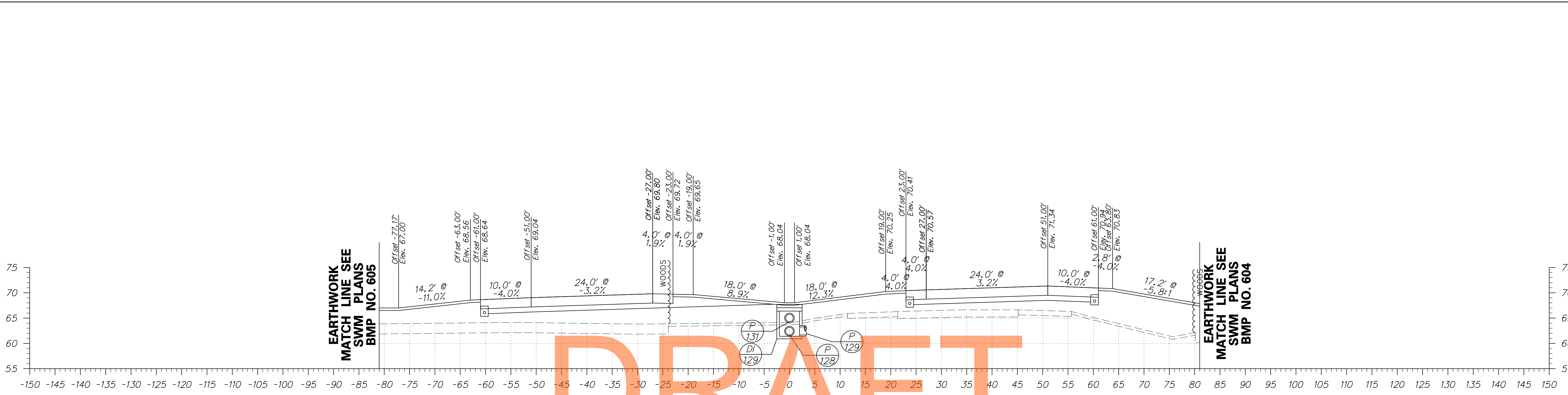

DRAFT

NOT FOR BIDDING

AUGUST 2015



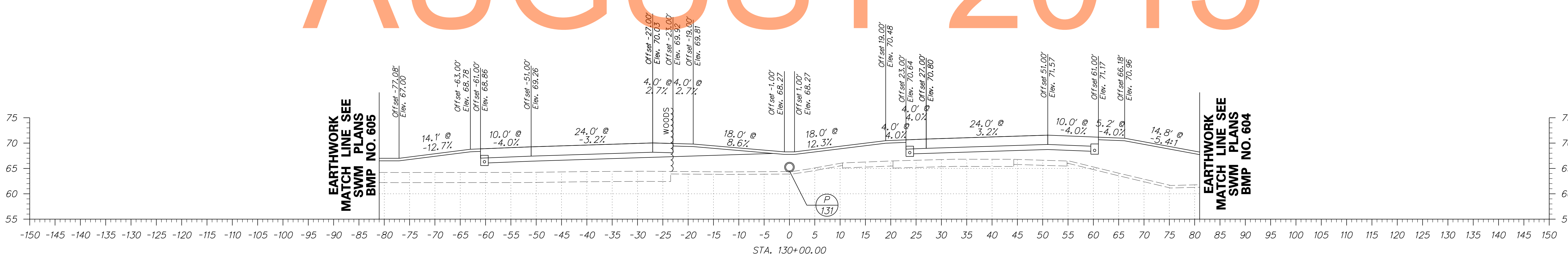
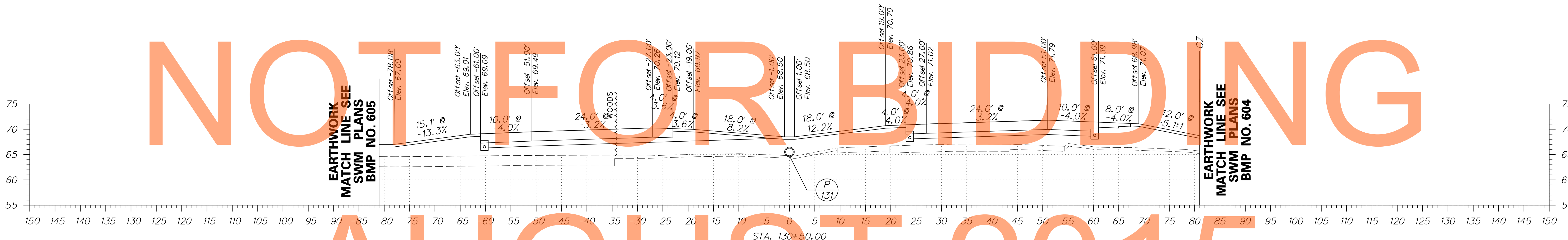
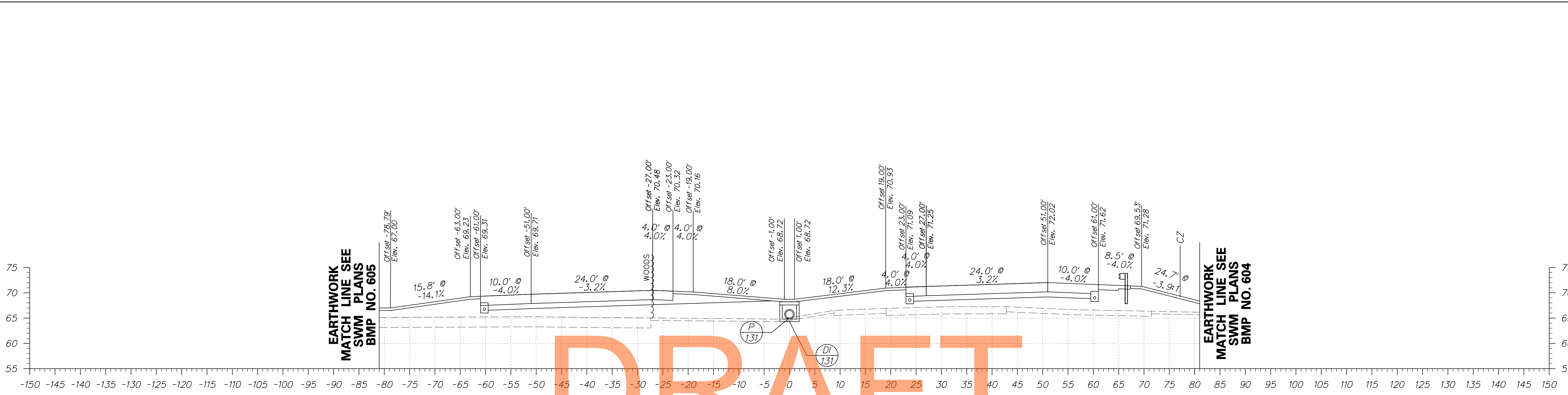

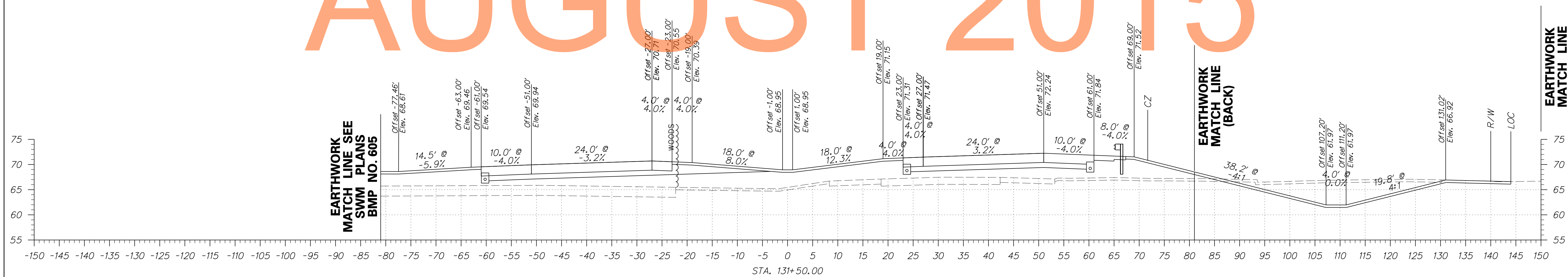
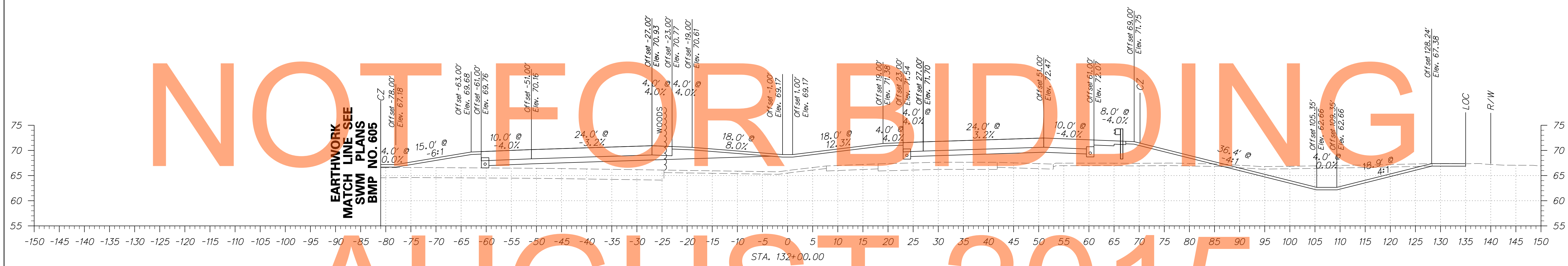
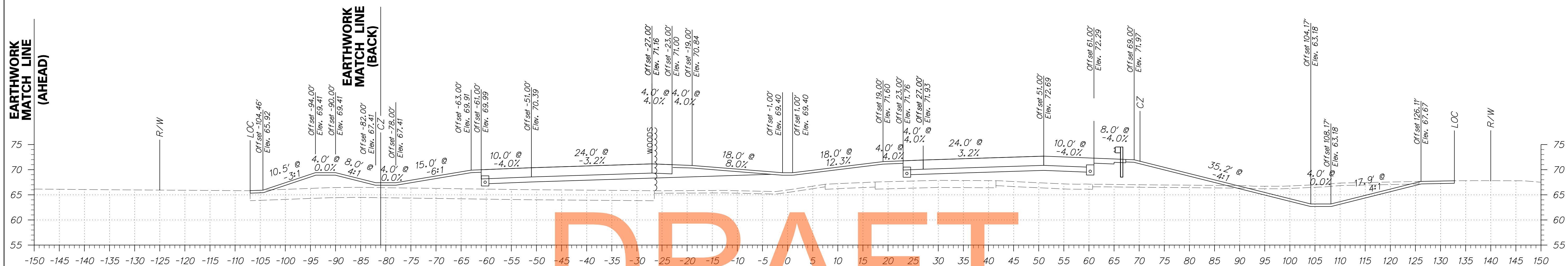

**DRAFT**

**NOT FOR BIDDING**

**AUGUST 2015**

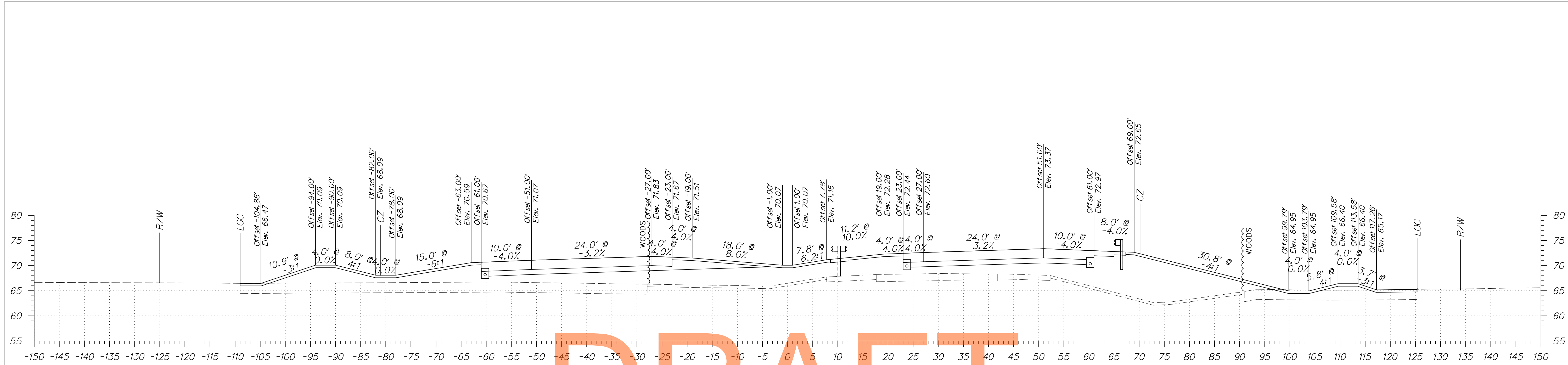

DRAFT

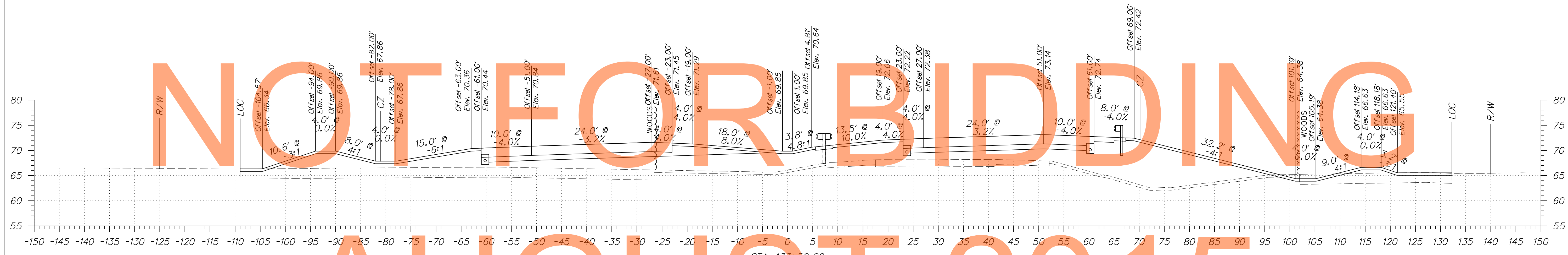

AUGUST 2015

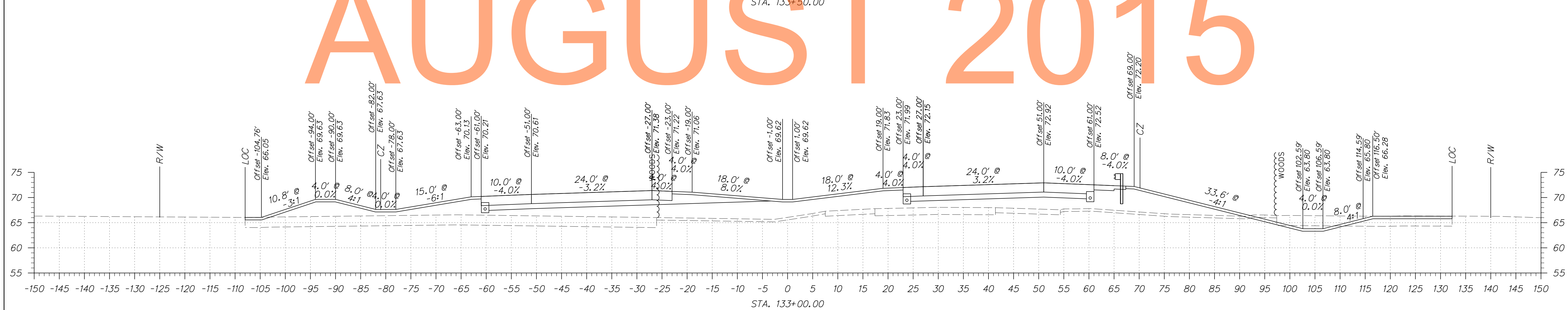

 <b>DELAWARE</b> DEPARTMENT OF TRANSPORTATION	ADDENDUMS / REVISIONS		SCALE 0 10 20 30 FEET	<b>US 301</b> <b>MARYLAND STATE LINE</b> <b>TO LEVELS ROAD</b>	CONTRACT T200811301 COUNTY NEW CASTLE	BRIDGE NO. DESIGNED BY: JEG CHECKED BY: MFM	<b>CROSS SECTIONS</b> <b>US 301 MAINLINE</b>	SHEET NO. 35 TOTAL SHTS. 539

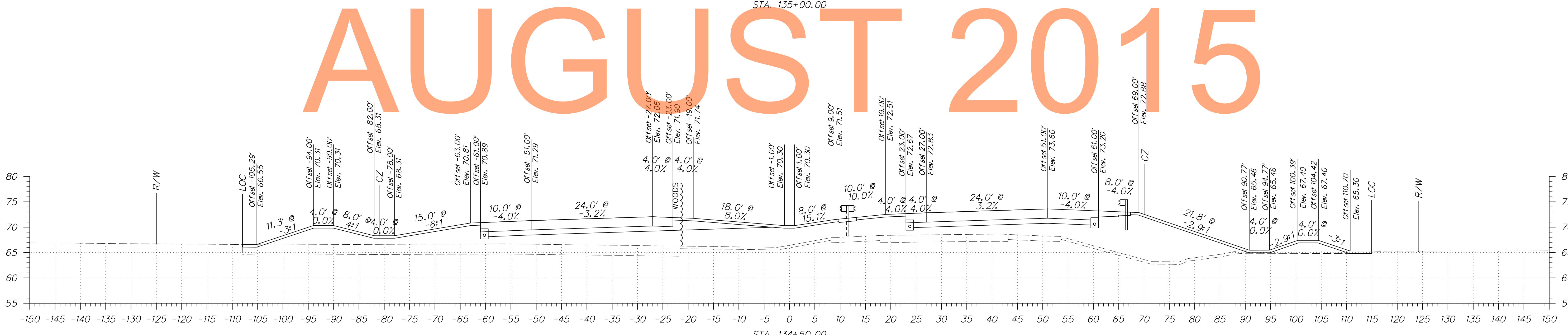
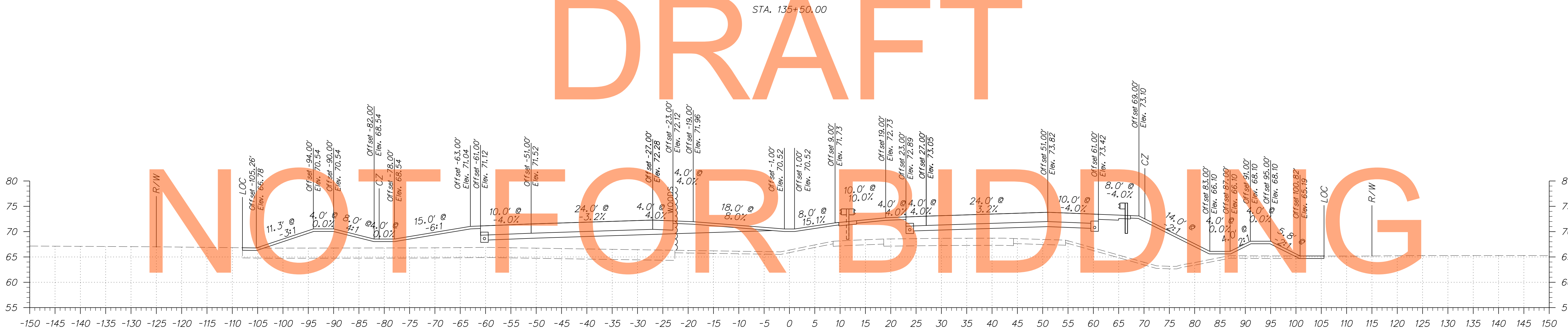
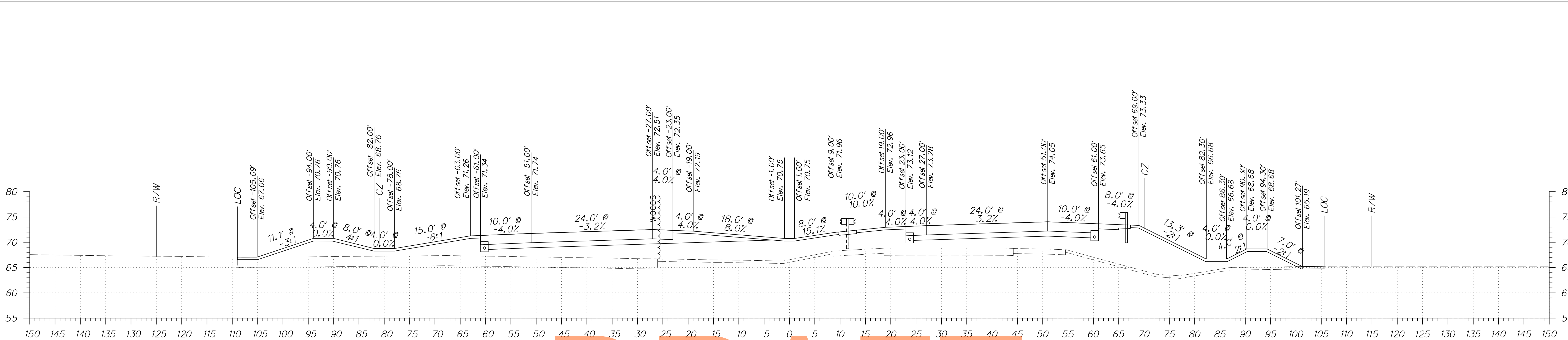

DRAFT

NOT FOR BIDDING

AUGUST 2015

ADDENDUMS / REVISIONS	

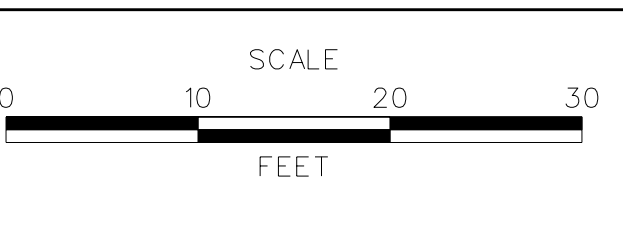

CONTRACT T200811301	BRIDGE NO.
COUNTY NEW CASTLE	DESIGNED BY: JEG
	CHECKED BY: MFM

EARTHWORK  
MATCH LINE  
(BACK)

EARTHWORK  
MATCH LINE  
(AHEAD)

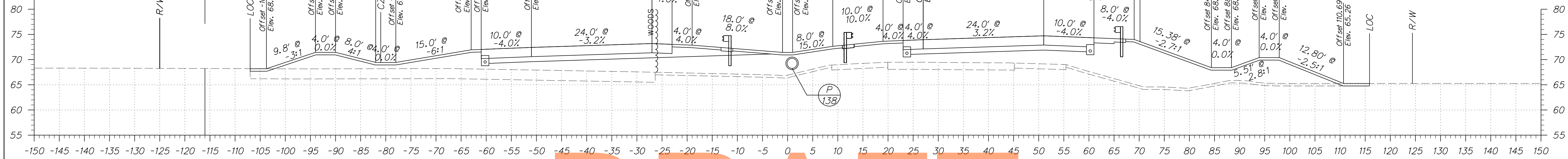

STA. 137+00.00

DRAFT

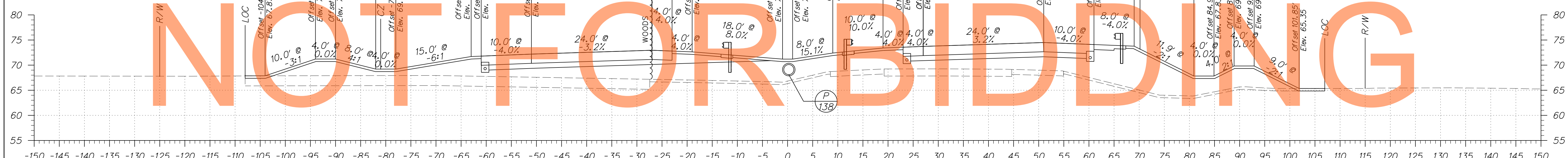

STA. 136+50.00

AUGUST 2015

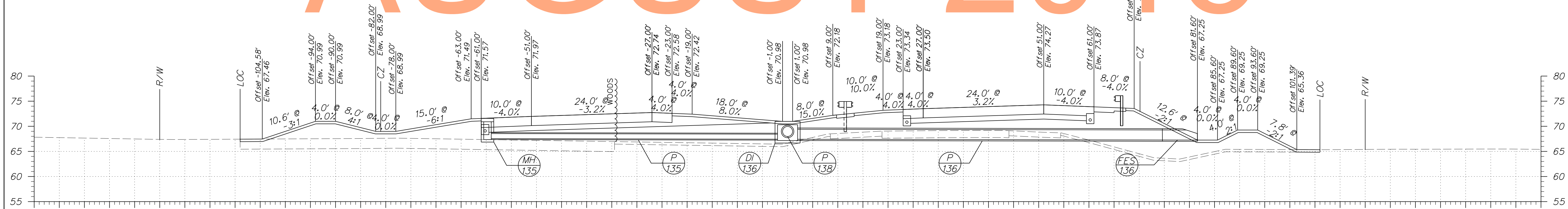

STA. 136+00.00

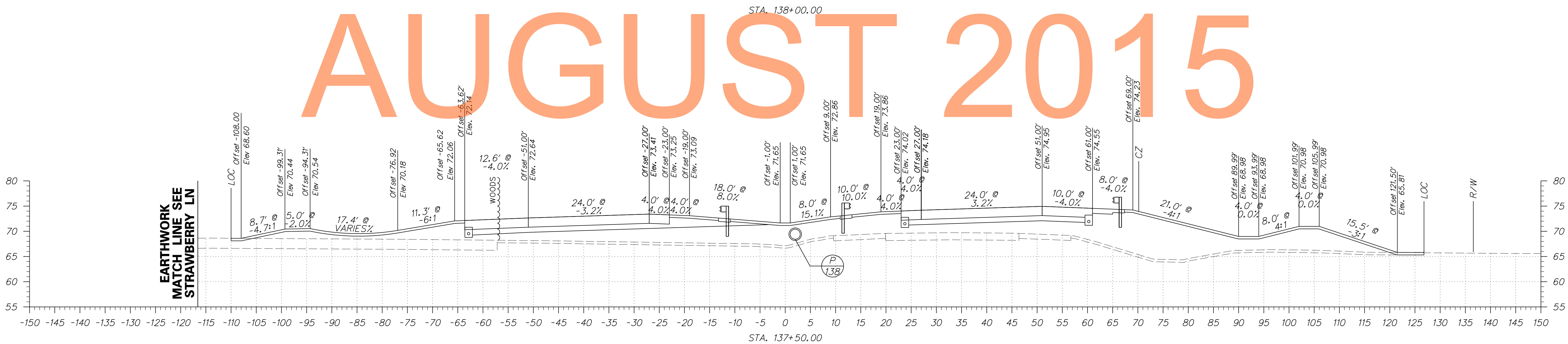
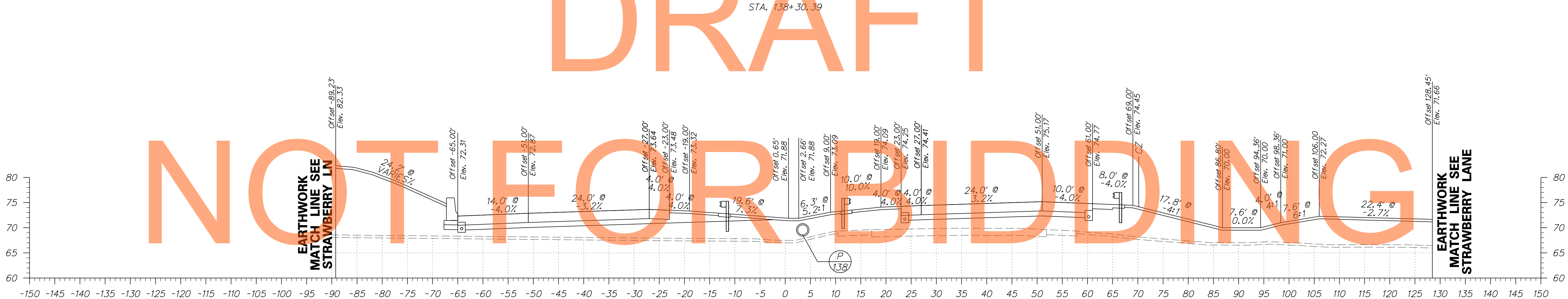
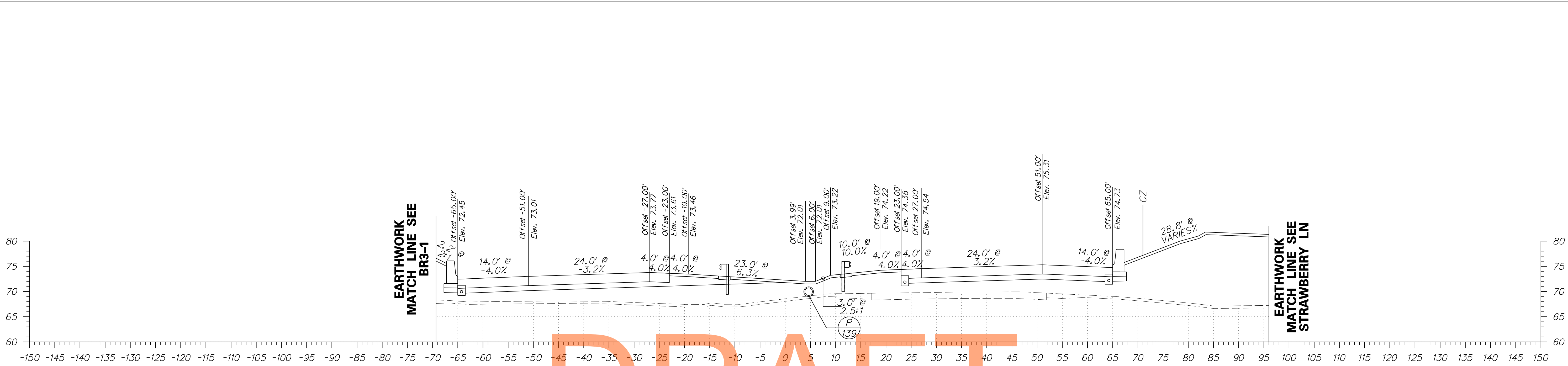

DRAFT

NOT FOR BIDDING

AUGUST 2015

ADDENDUMS / REVISIONS	

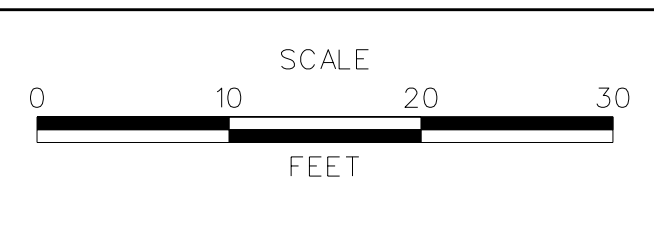

CONTRACT T200811301	BRIDGE NO.
COUNTY NEW CASTLE	DESIGNED BY: JEG
	CHECKED BY: MFM

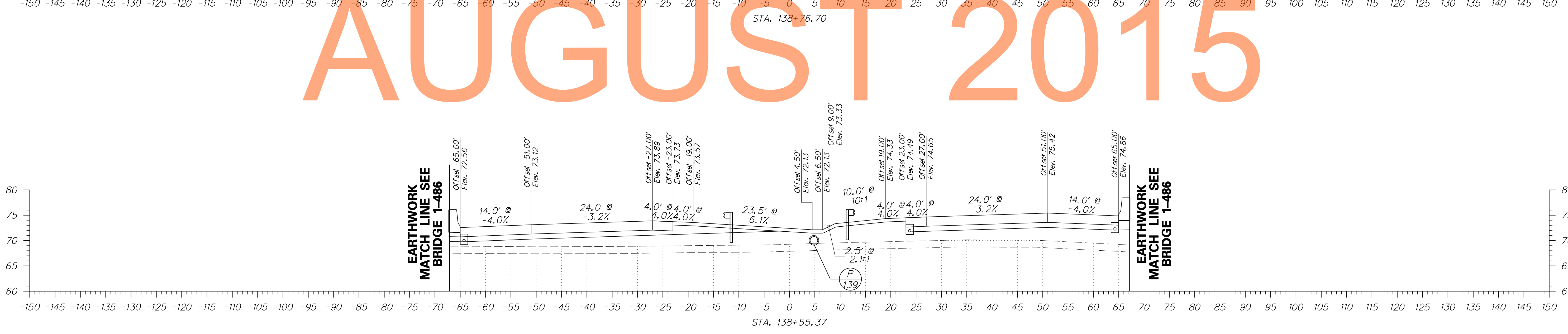
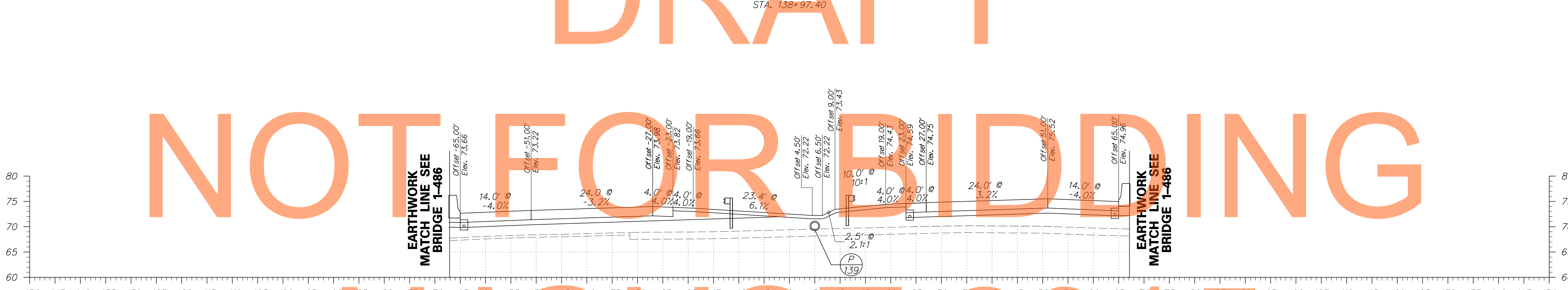
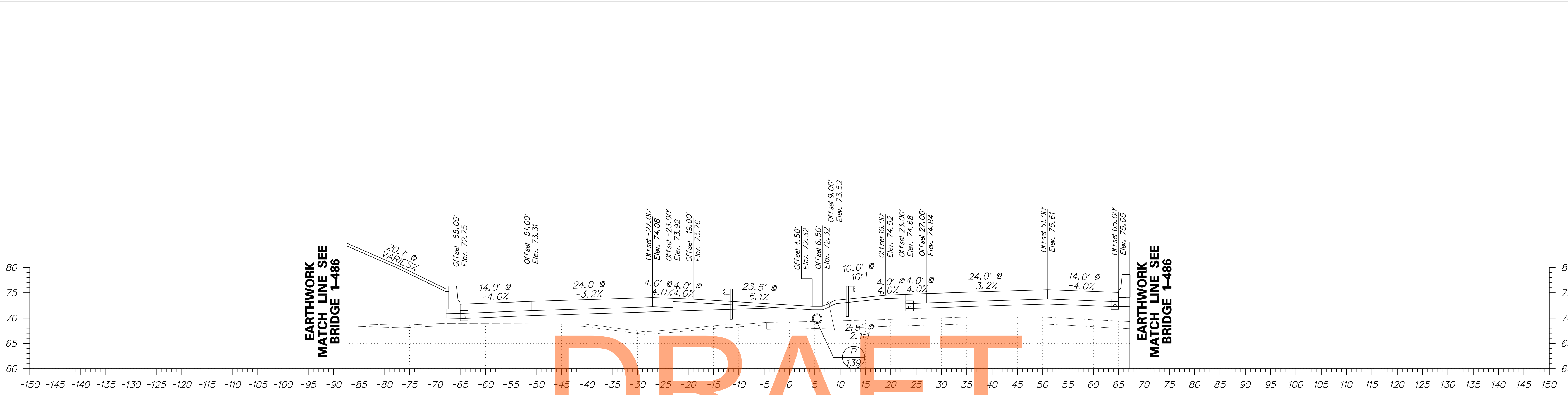

DRAFT

NOT FOR BIDDING

AUGUST 2015

ADDENDUMS / REVISIONS	

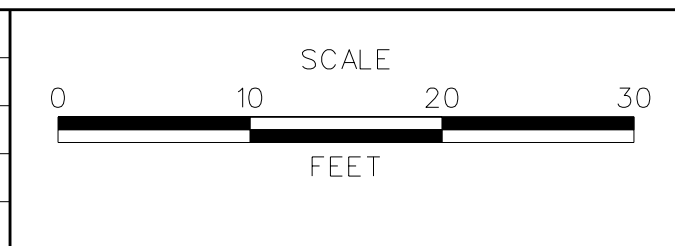

CONTRACT T200811301	BRIDGE NO. 
COUNTY NEW CASTLE	DESIGNED BY: JEG
	CHECKED BY: MFM

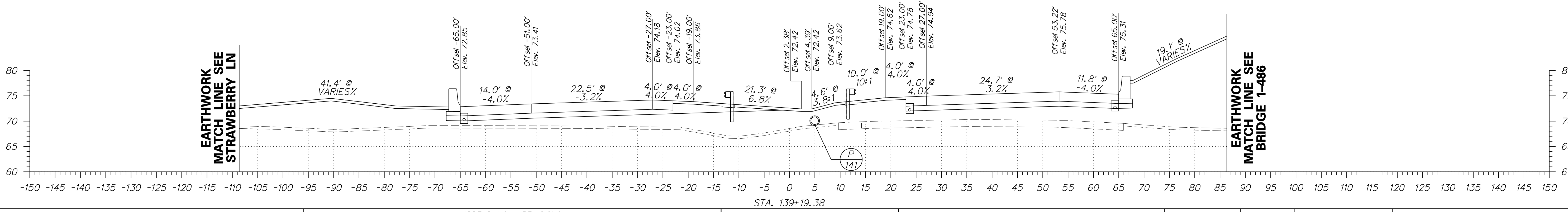
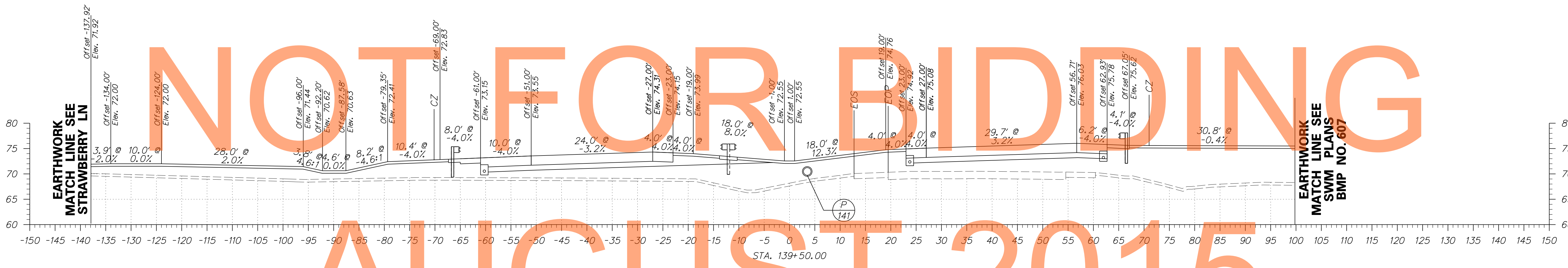
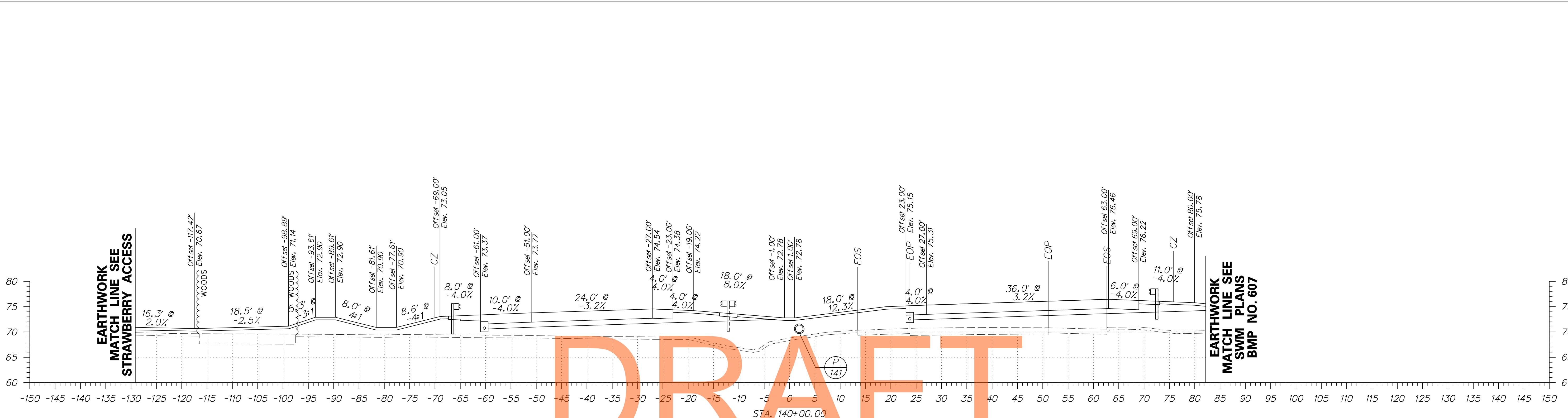

ADDENDUMS / REVISIONS

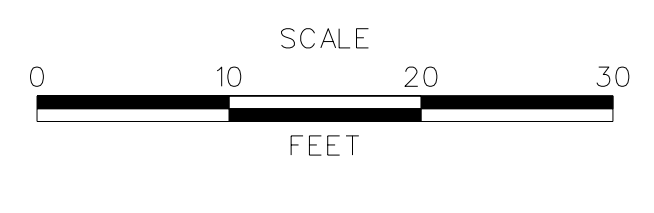

**US 301 MARYLAND STATE LINE TO LEVELS ROAD**

CONTRACT T200811301	BRIDGE NO.
COUNTY NEW CASTLE	DESIGNED BY: JEG
	CHECKED BY: MFM

**CROSS SECTIONS US 301 MAINLINE**

SHEET NO. 40
TOTAL SHTS. 539



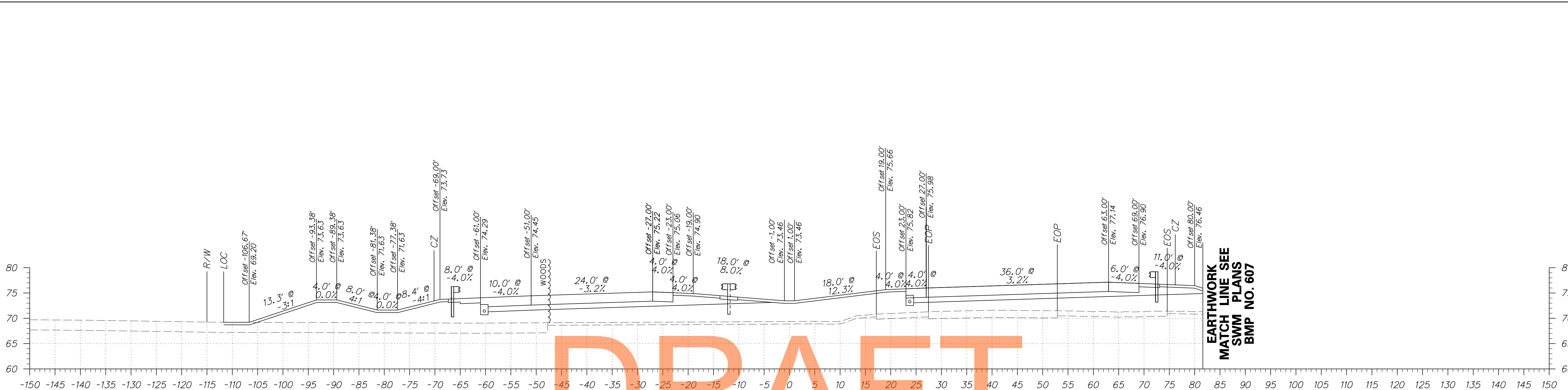

DRAFT

EARTHWORK  
MATCH LINE SEE  
SWM PLANS  
BMP NO. 607

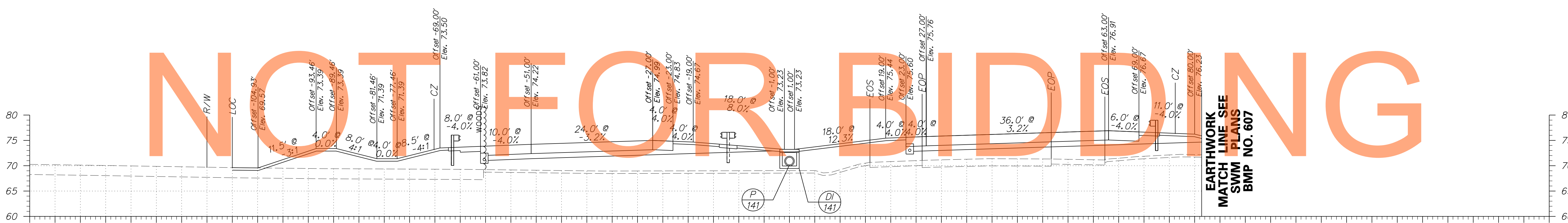

EARTHWORK  
MATCH LINE SEE  
SWM PLANS  
BMP NO. 607

AUGUST 2015

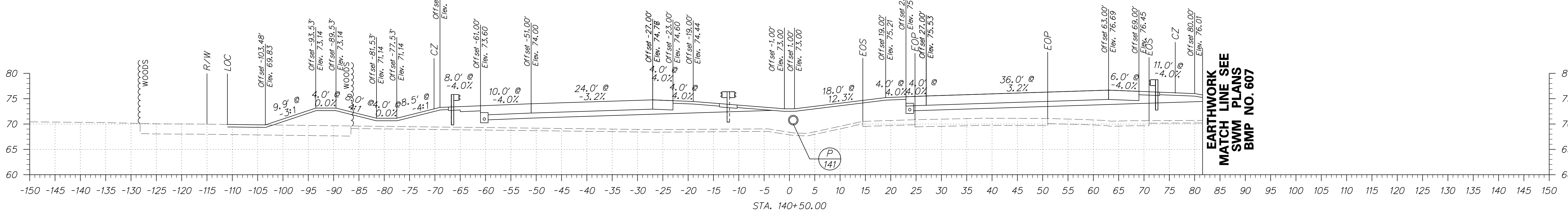

EARTHWORK  
MATCH LINE SEE  
SWM PLANS  
BMP NO. 607

ADDENDUMS / REVISIONS

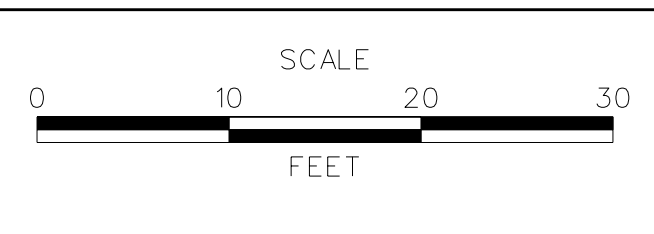

CONTRACT T200811301	BRIDGE NO.
COUNTY NEW CASTLE	DESIGNED BY: JEG CHECKED BY: MFM

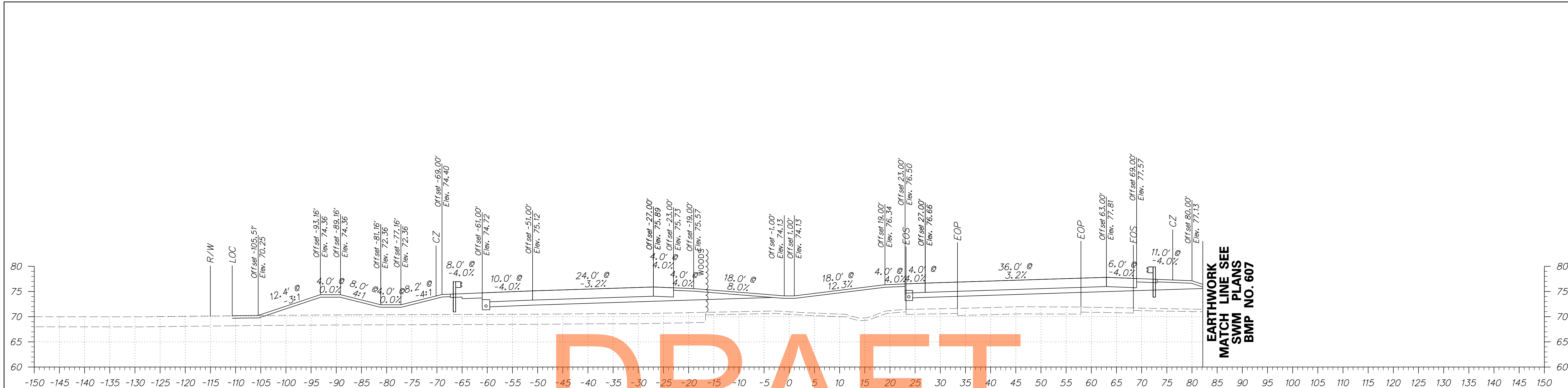

DRAFT

EARTHWORK  
MATCH LINE SEE  
SWM PLANS  
BMP NO. 607

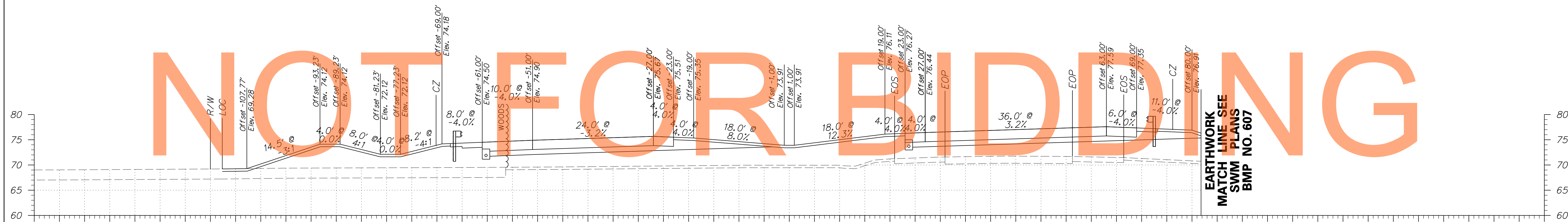

EARTHWORK  
MATCH LINE SEE  
SWM PLANS  
BMP NO. 607

AUGUST 2015

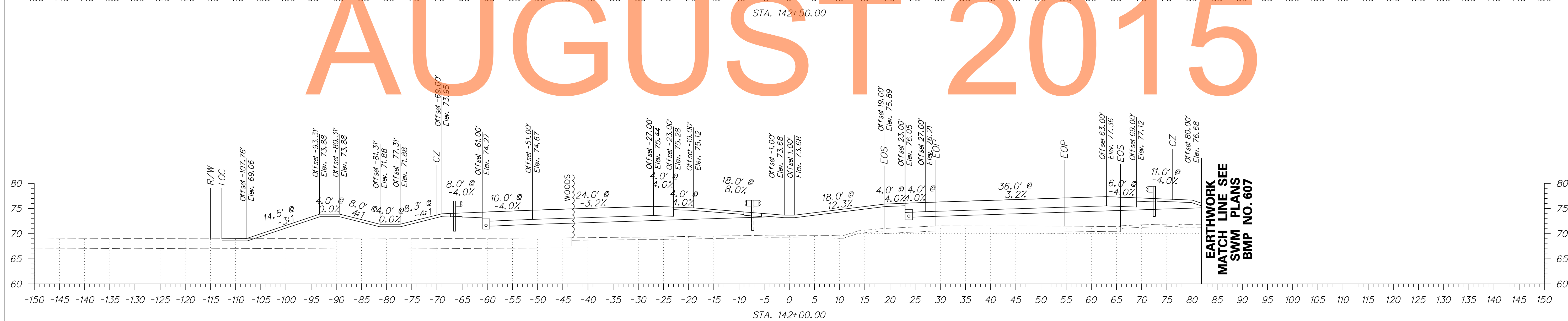

EARTHWORK  
MATCH LINE SEE  
SWM PLANS  
BMP NO. 607

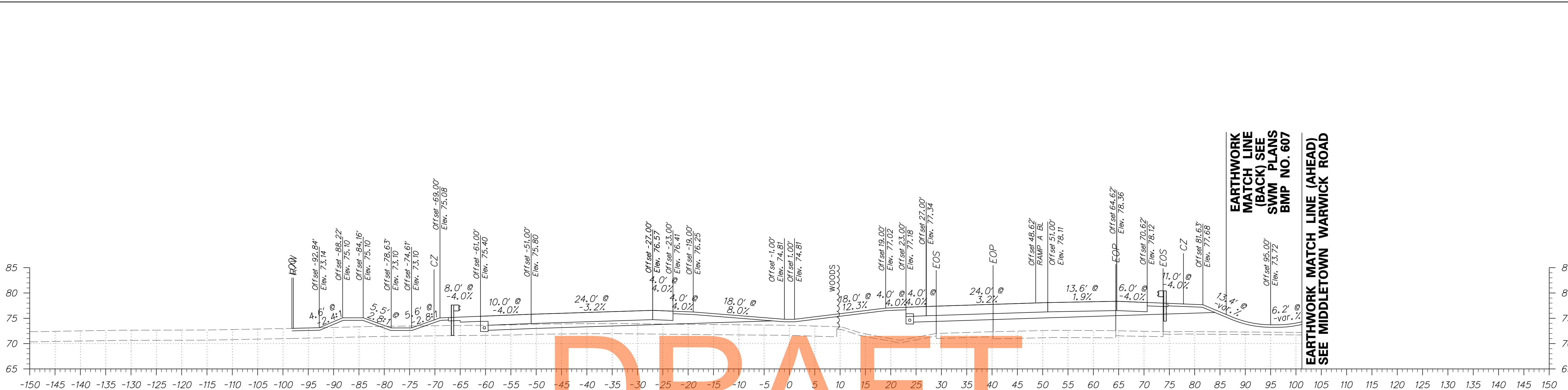

EARTHWORK MATCH LINE (AHEAD)  
MATCH LINE (BACK) SEE SWM PLANS BMP NO. 607

EARTHWORK MATCH LINE (AHEAD)  
SEE MIDDLETOWN WARWICK ROAD

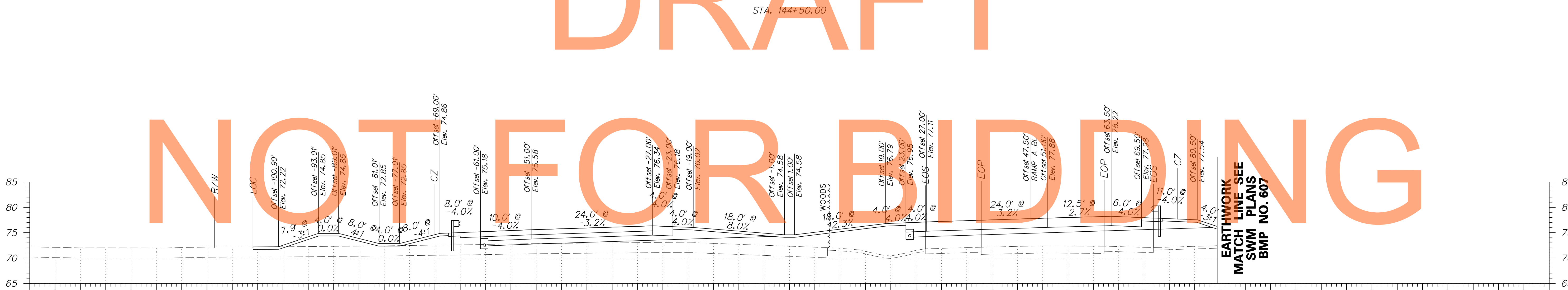

EARTHWORK MATCH LINE SEE SWM PLANS BMP NO. 607

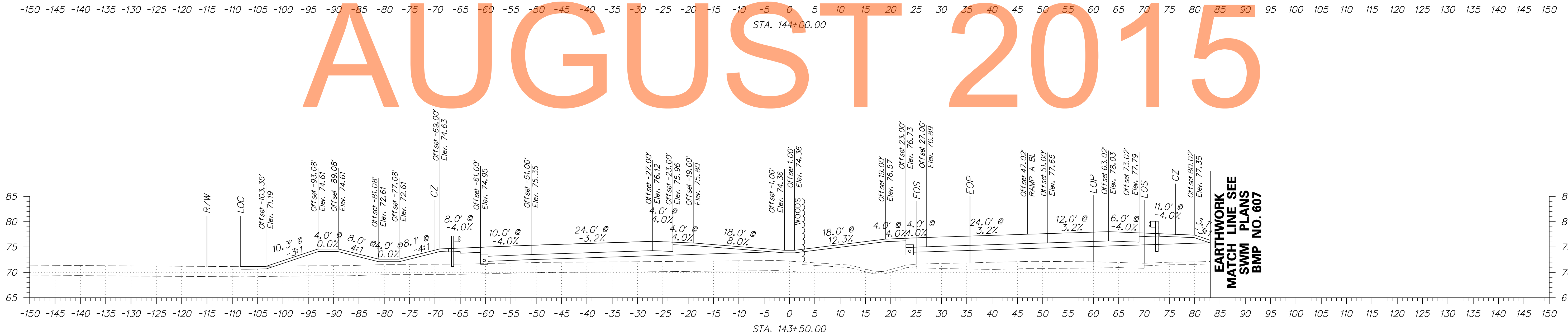

EARTHWORK MATCH LINE SEE SWM PLANS BMP NO. 607

DRAFT

NOT FOR BIDDING

AUGUST 2015



ADDENDUMS / REVISIONS	

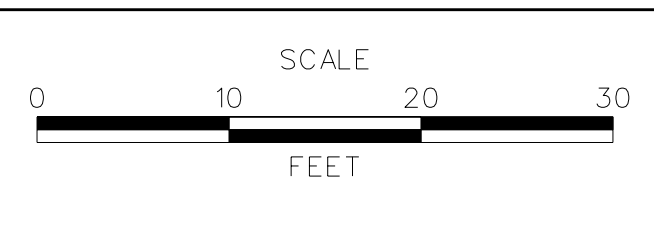

**US 301  
MARYLAND STATE LINE  
TO LEVELS ROAD**

CONTRACT T200811301	BRIDGE NO.
COUNTY NEW CASTLE	DESIGNED BY: JEG
	CHECKED BY: MFM

<b>CROSS SECTIONS US 301 MAINLINE</b>	SHEET NO. 43
	TOTAL SHTS. 539

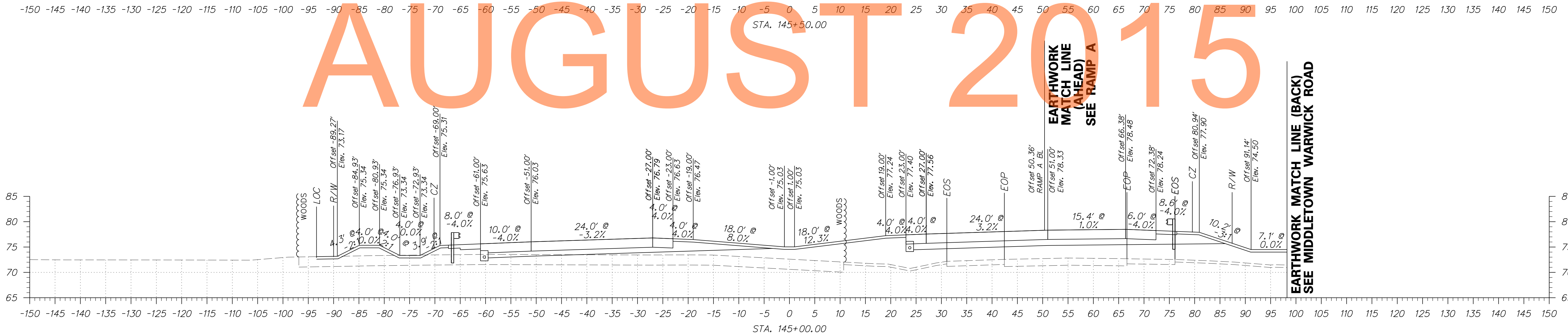
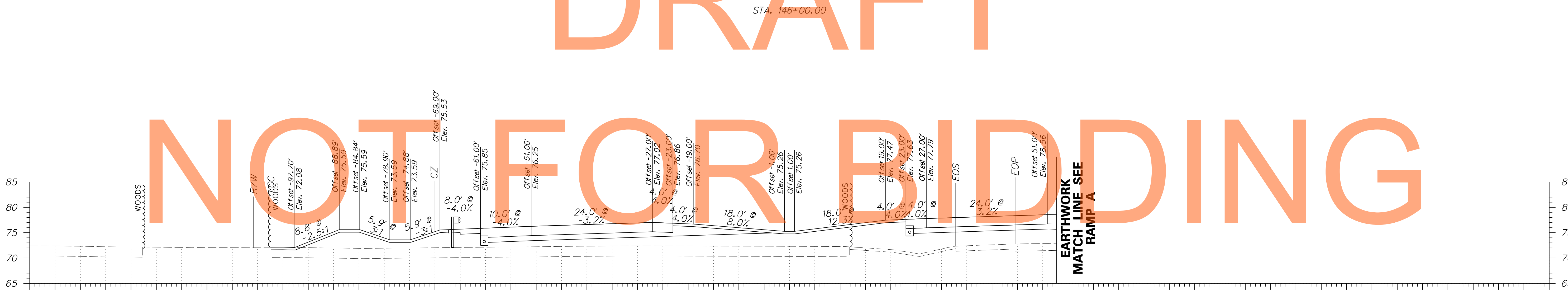
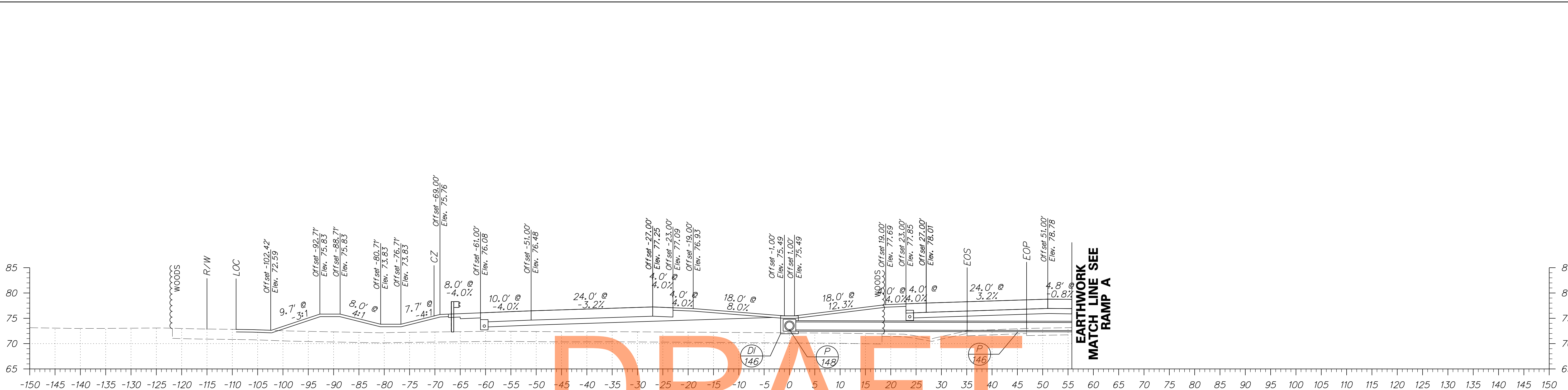

ADDENDUMS / REVISIONS

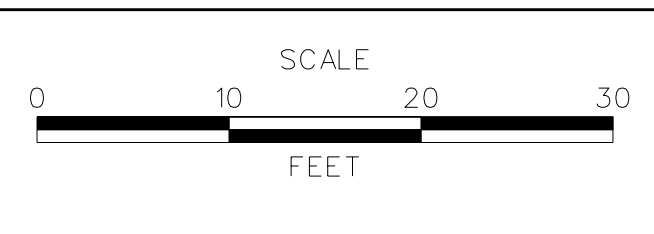

CONTRACT T200811301	BRIDGE NO.
COUNTY NEW CASTLE	DESIGNED BY: JEG
	CHECKED BY: MFM

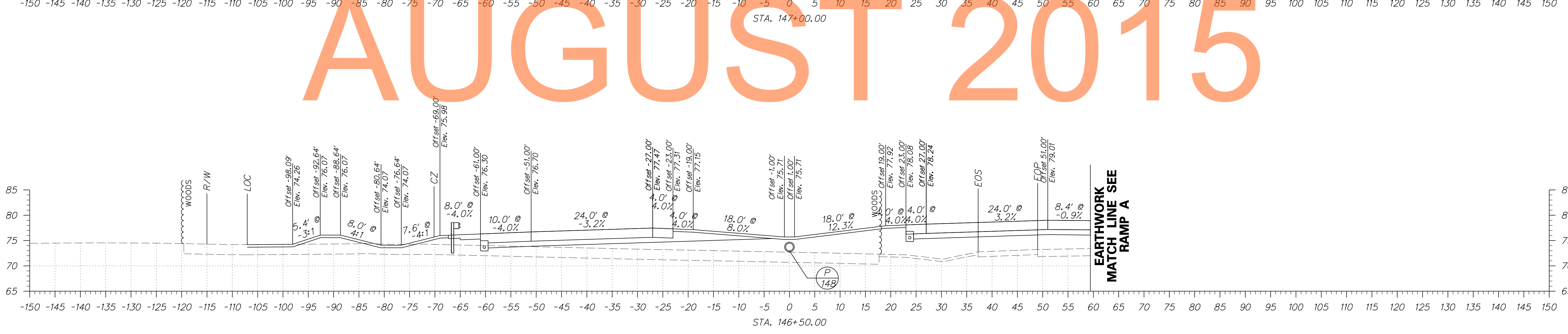
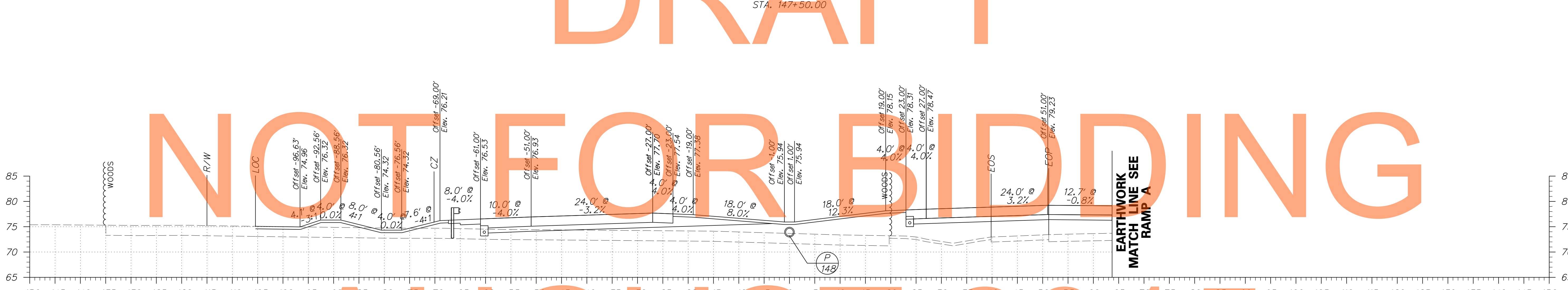
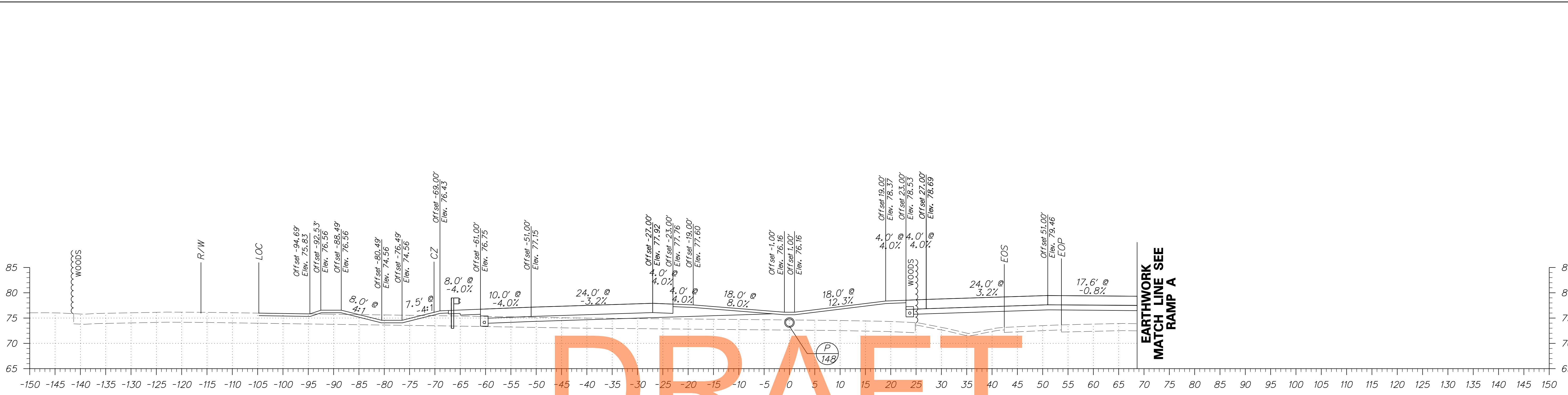

DRAFT

NOT FOR BIDDING

AUGUST 2015

ADDENDUMS / REVISIONS

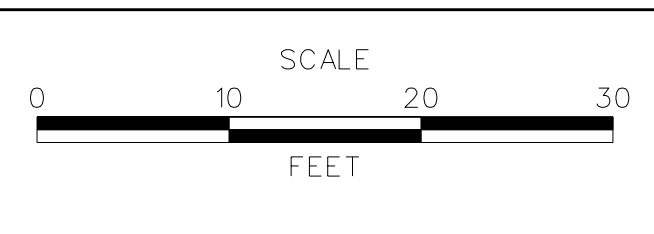

**US 301**  
**MARYLAND STATE LINE**  
**TO LEVELS ROAD**

CONTRACT T200811301	BRIDGE NO.
COUNTY NEW CASTLE	DESIGNED BY: JEG
	CHECKED BY: MFM

**CROSS SECTIONS**  
**US 301 MAINLINE**

SHEET NO. 45
TOTAL SHTS. 539

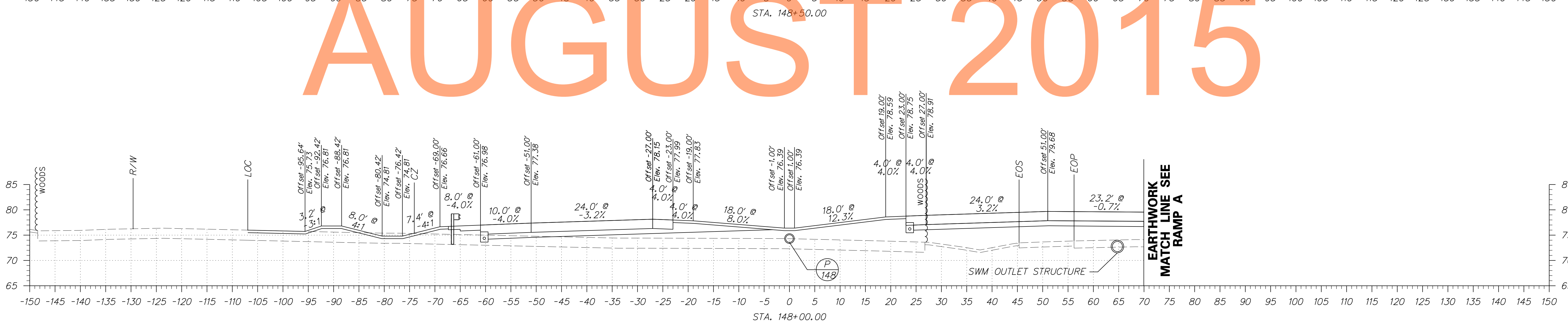
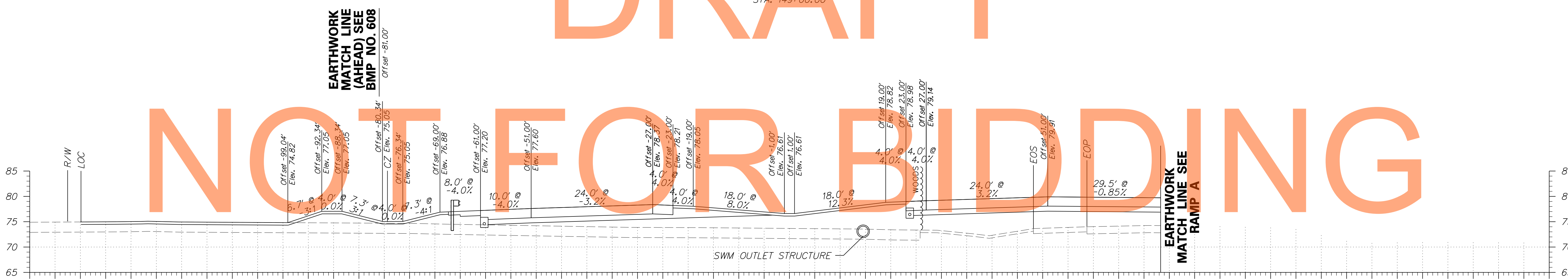
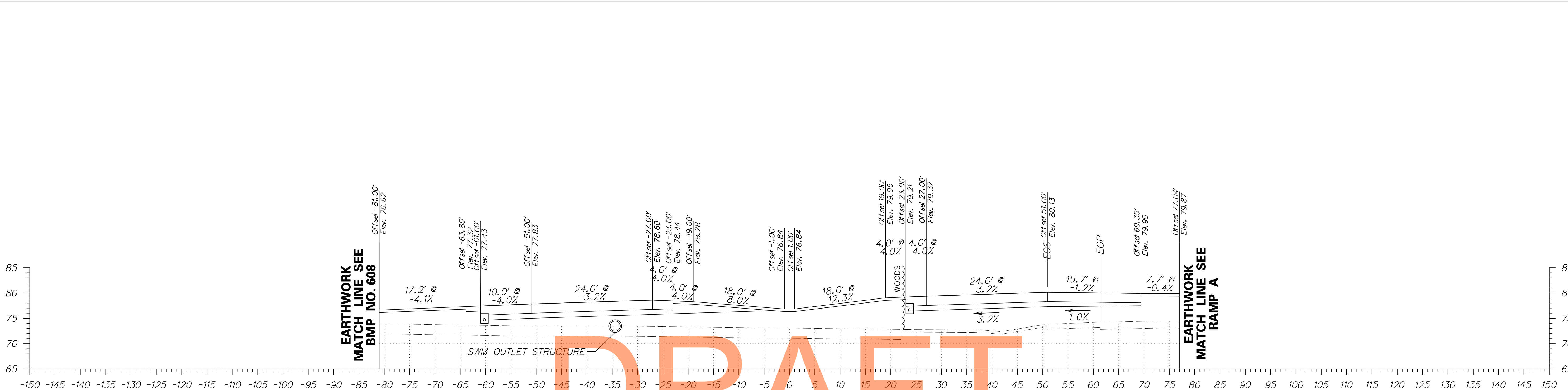

DRAFT

NOT FOR BIDDING

AUGUST 2015

ADDENDUMS / REVISIONS	

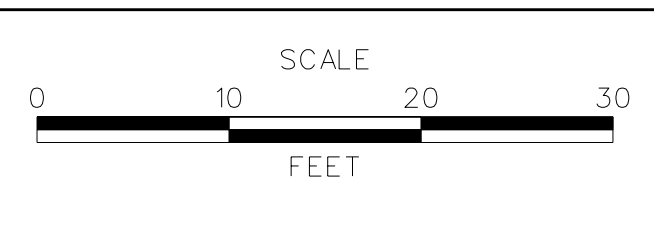

**US 301**  
**MARYLAND STATE LINE**  
**TO LEVELS ROAD**

CONTRACT T200811301	BRIDGE NO.
COUNTY NEW CASTLE	DESIGNED BY: JEG
	CHECKED BY: MFM

<b>CROSS SECTIONS</b> <b>US 301 MAINLINE</b>
SHEET NO. 46
TOTAL SHTS. 539

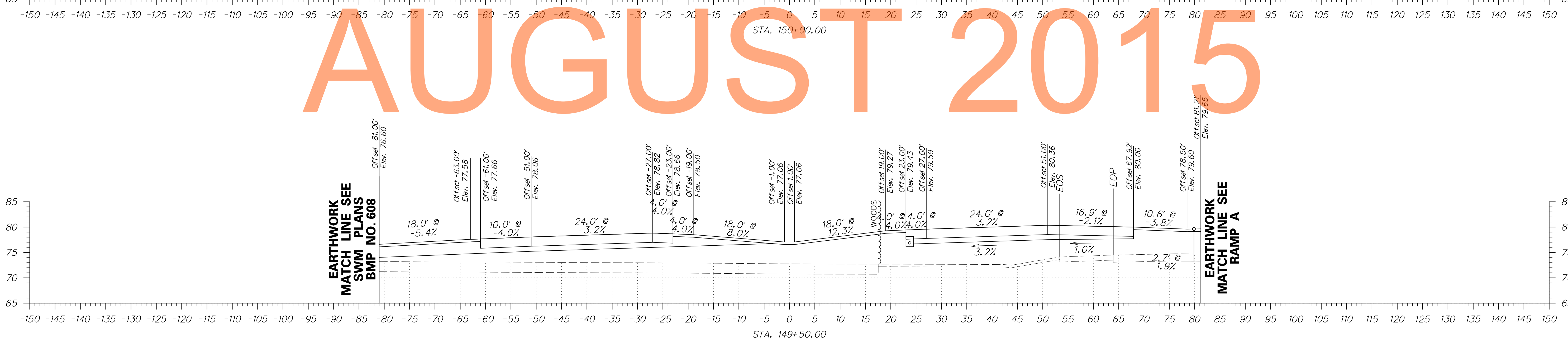
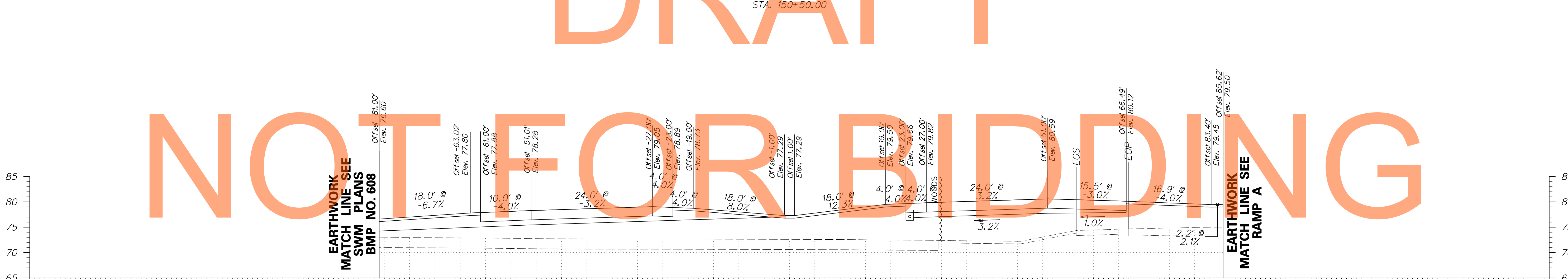
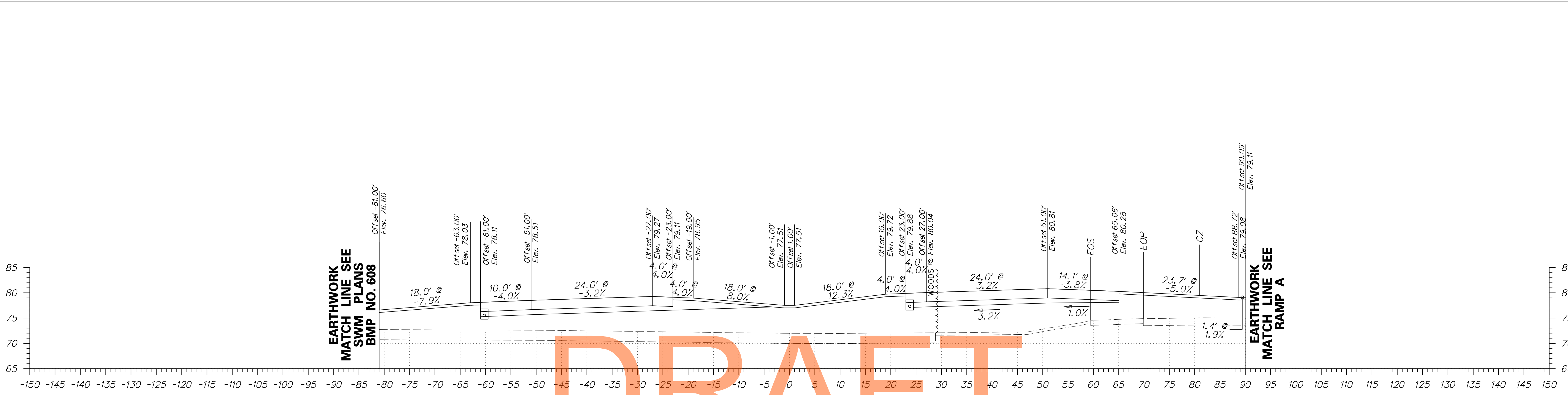

DRAFT

NOT FOR BIDDING

AUGUST 2015

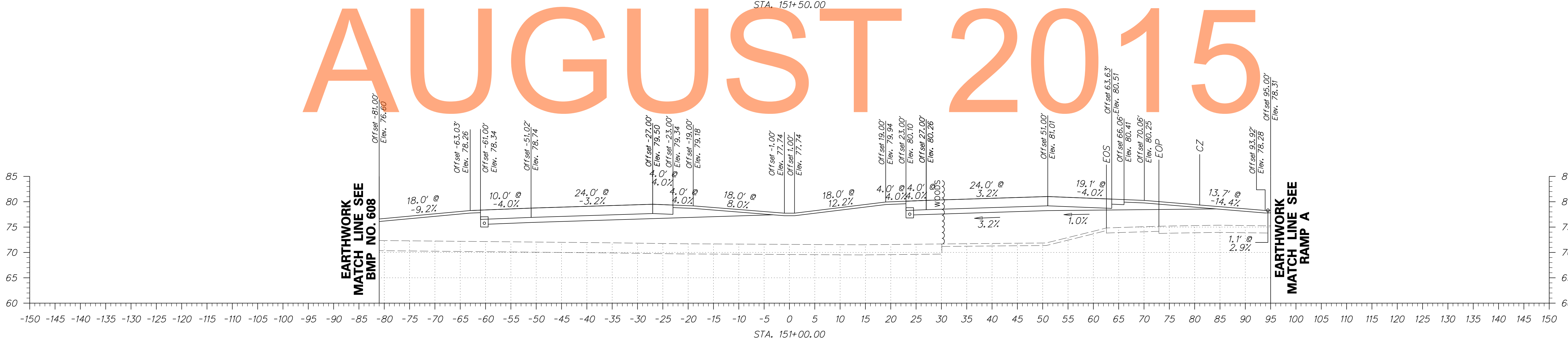
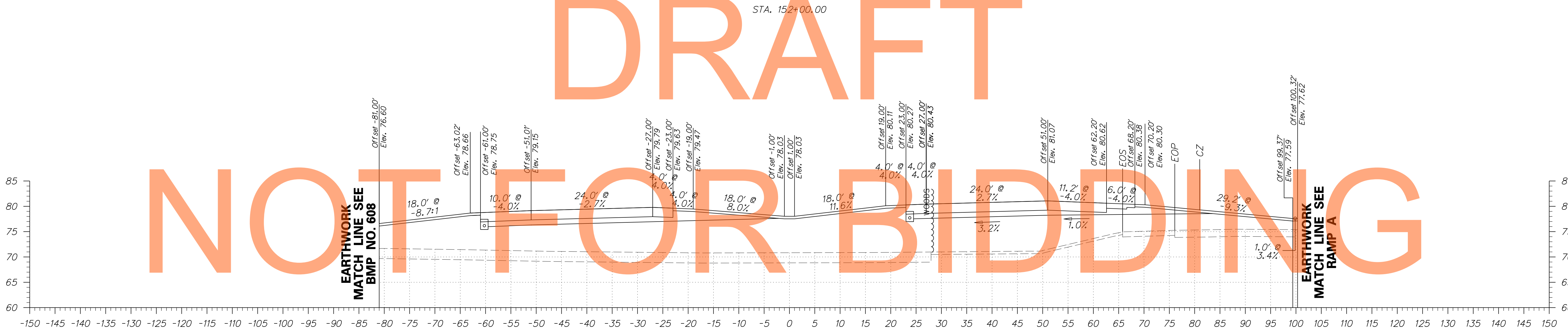
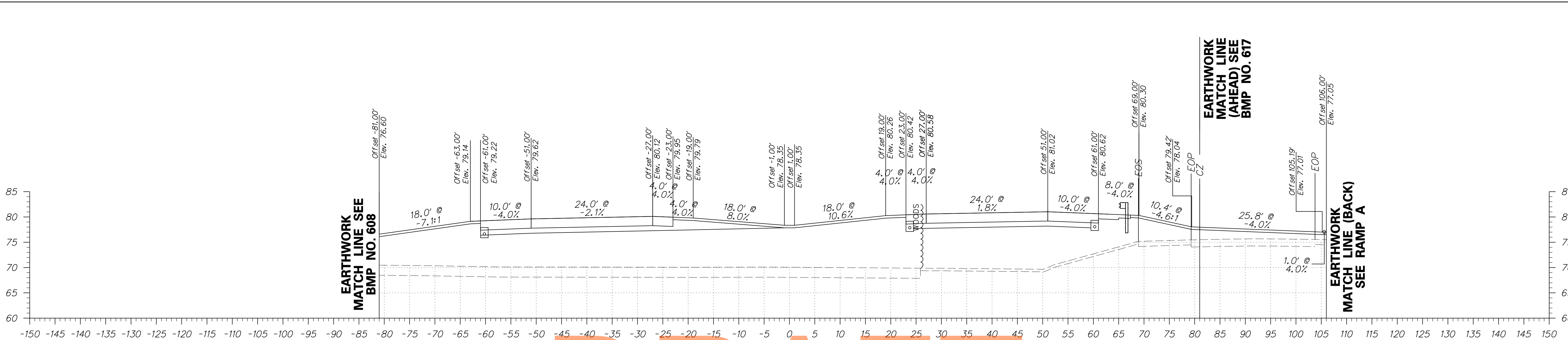

DRAFT  
NOT FOR BIDDING  
AUGUST 2015



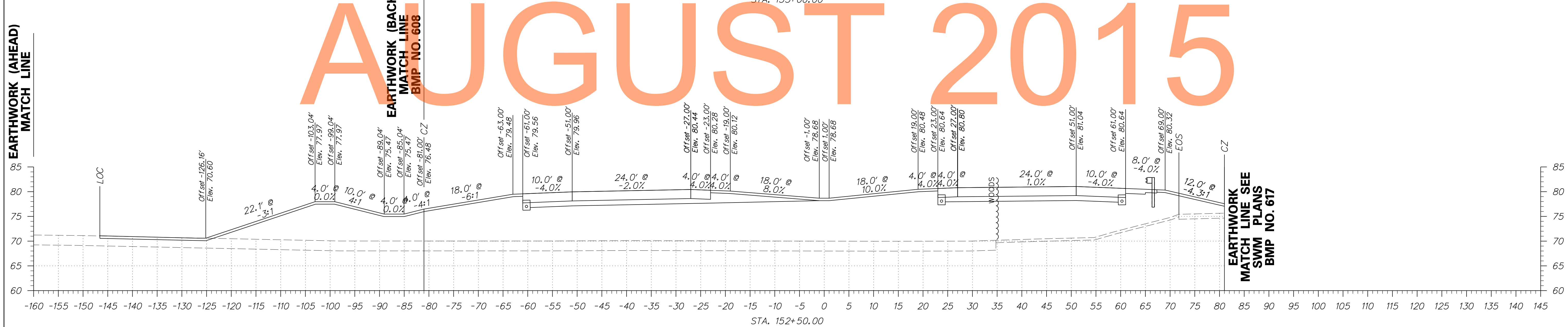
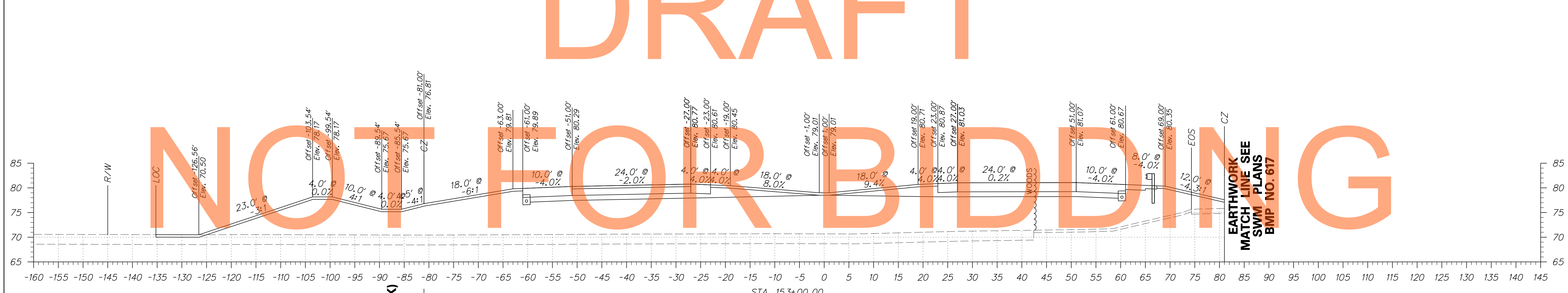
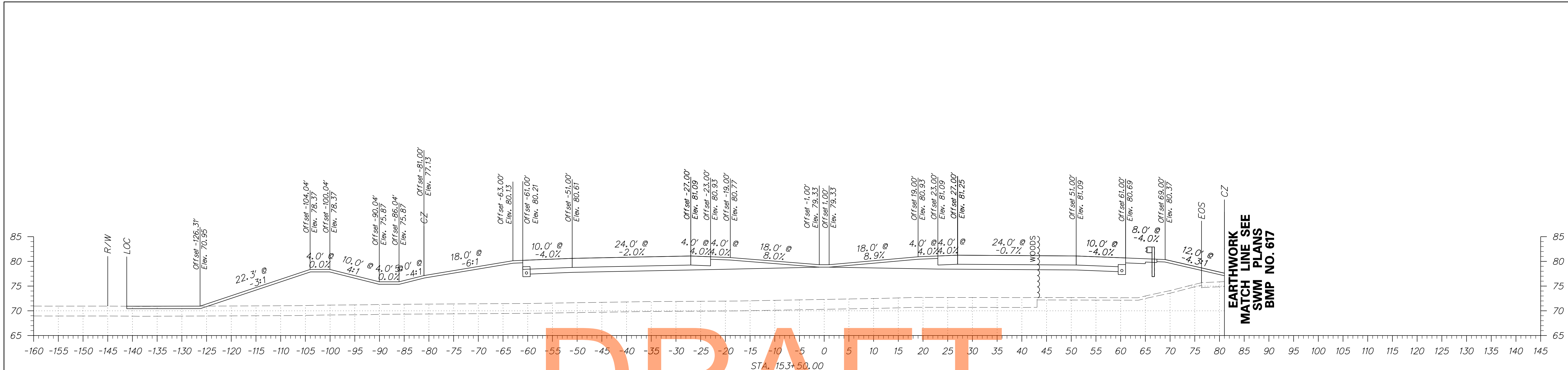

DRAFT

NOT FOR BIDDING

AUGUST 2015

DRAFT

NOT FOR BIDDING

AUGUST 2015

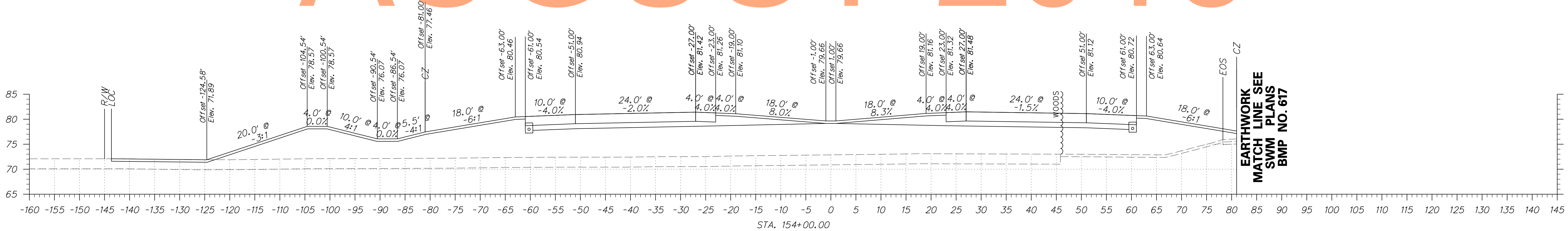
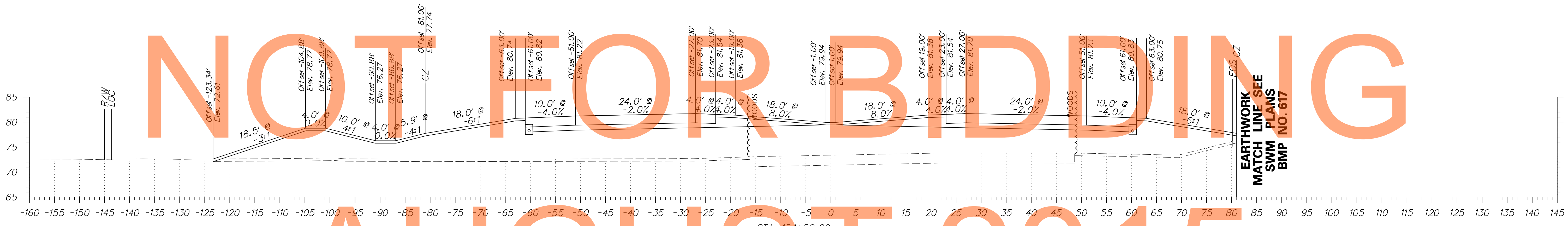
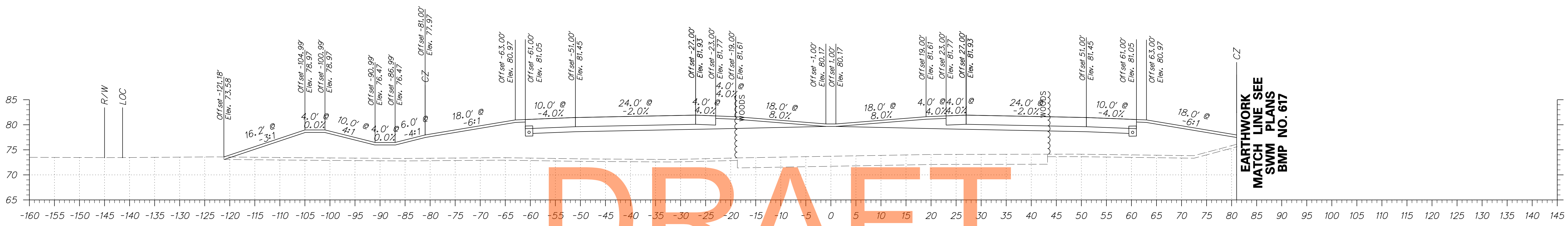

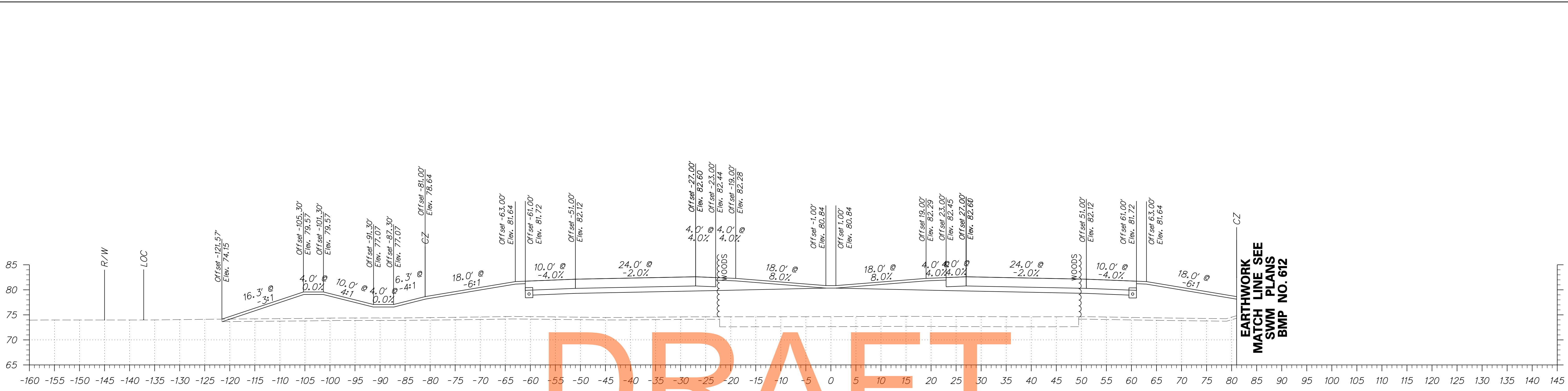

DRAFT

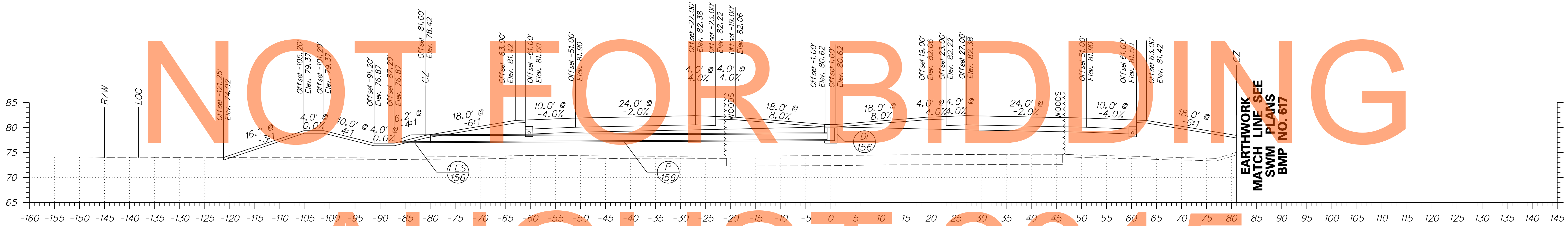

AUGUST 2015

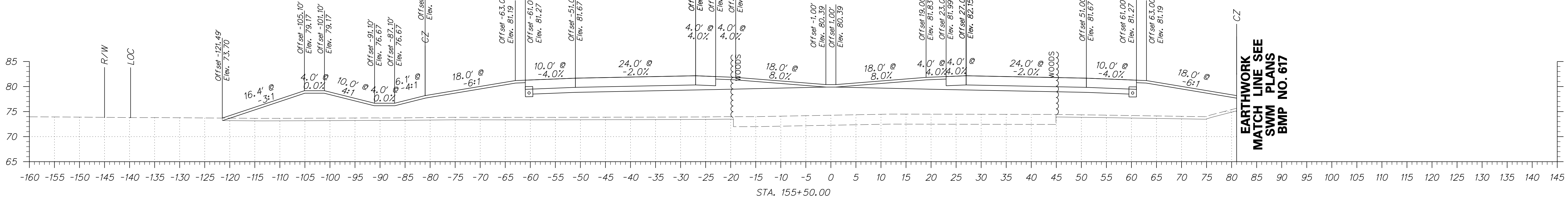

ADDENDUMS / REVISIONS	

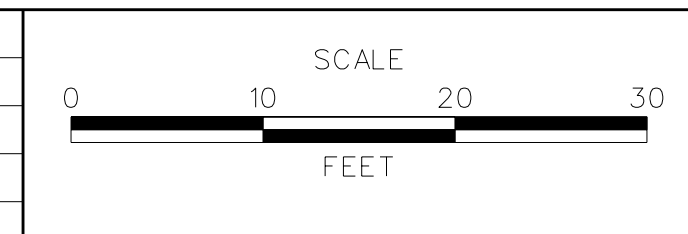

**US 301**  
**MARYLAND STATE LINE**  
**TO LEVELS ROAD**

CONTRACT T200811301	BRIDGE NO.
COUNTY NEW CASTLE	DESIGNED BY: JEG
	CHECKED BY: MFM

<b>CROSS SECTIONS</b> <b>US 301 MAINLINE</b>	SHEET NO. 51
	TOTAL SHTS. 539

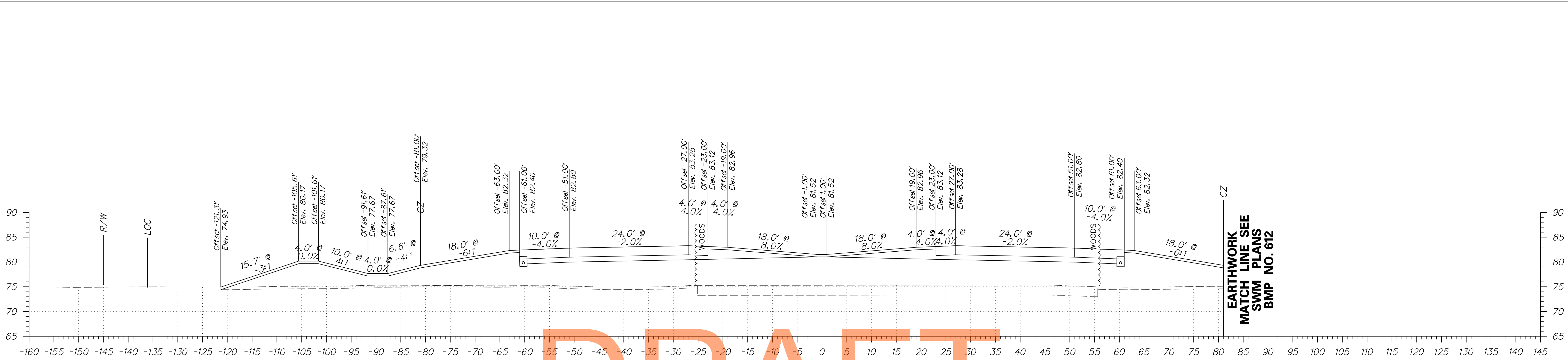

EARTHWORK  
MATCH LINE SEE  
SWM PLANS  
BMP NO. 612

DRAFT

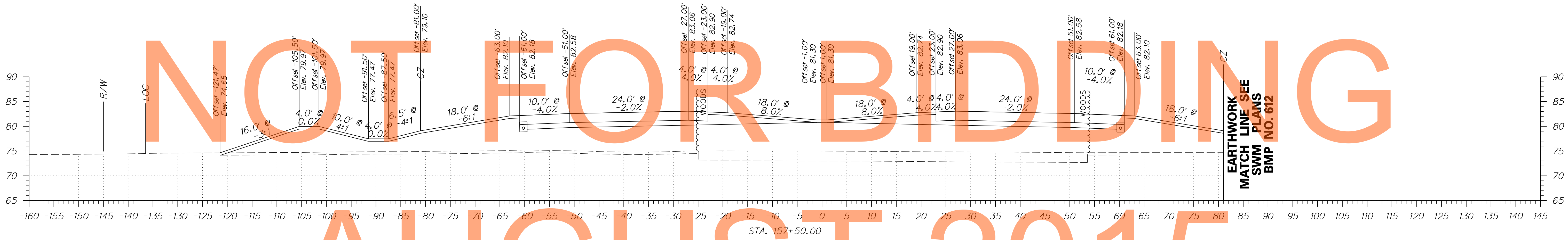

EARTHWORK  
MATCH LINE SEE  
SWM PLANS  
BMP NO. 612

AUGUST 2015

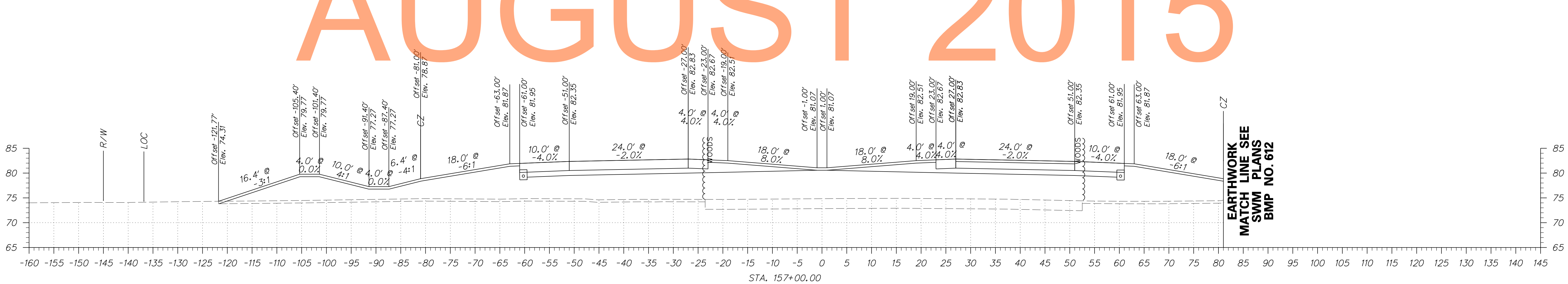

EARTHWORK  
MATCH LINE SEE  
SWM PLANS  
BMP NO. 612



ADDENDUMS / REVISIONS	

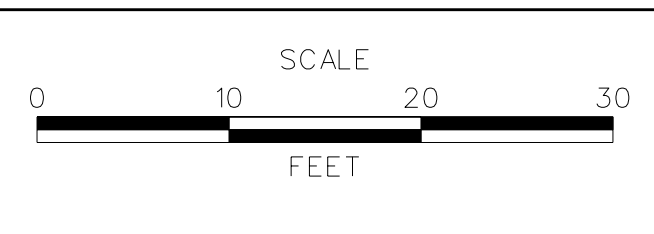

US 301  
MARYLAND STATE LINE  
TO LEVELS ROAD

CONTRACT T200811301	BRIDGE NO.
COUNTY NEW CASTLE	DESIGNED BY: JEG
	CHECKED BY: MFM

CROSS SECTIONS  
US 301 MAINLINE

SHEET NO. 52
TOTAL SHTS. 539

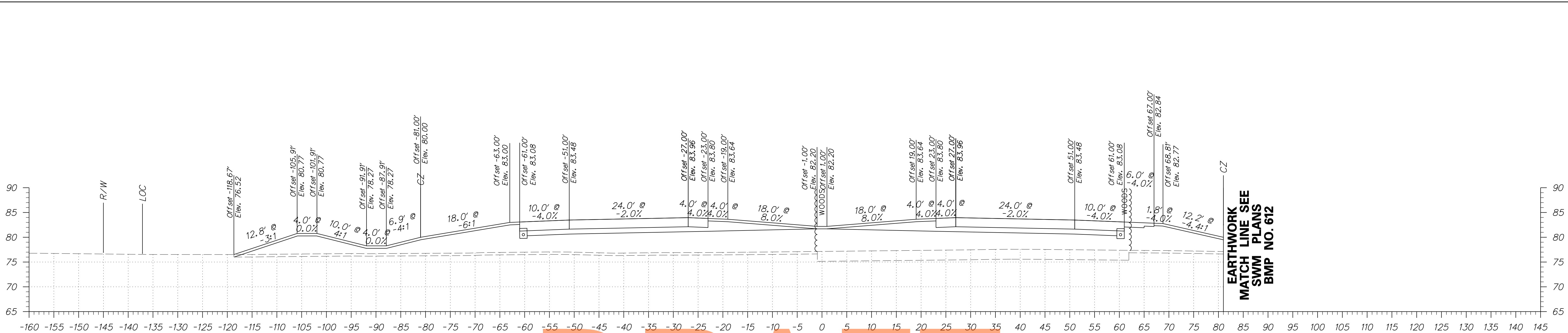

EARTHWORK  
MATCH LINE SEE  
SWM PLANS  
BMP NO. 612

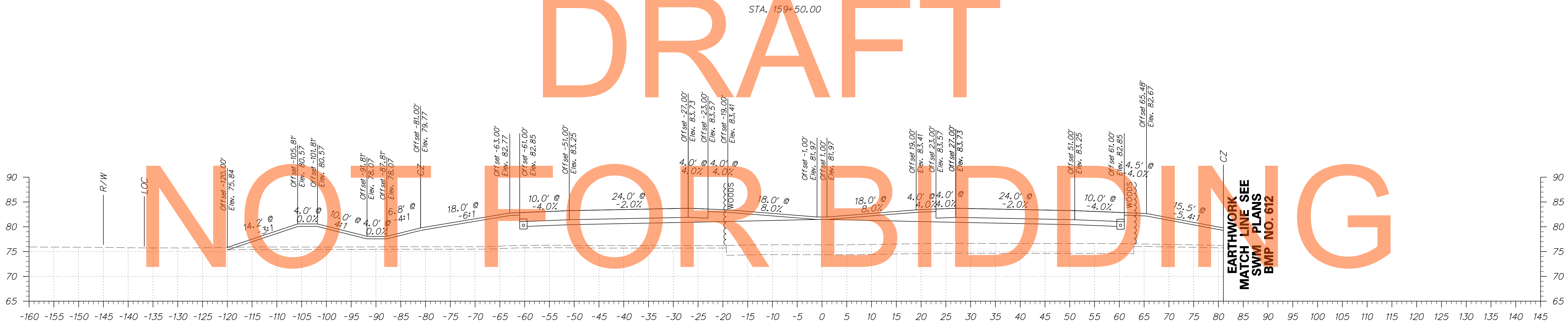

EARTHWORK  
MATCH LINE SEE  
SWM PLANS  
BMP NO. 612

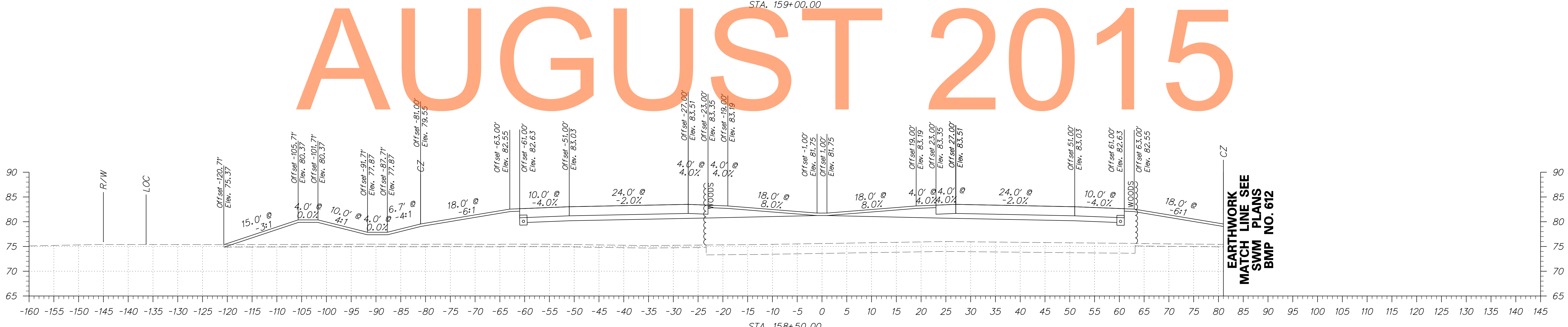

EARTHWORK  
MATCH LINE SEE  
SWM PLANS  
BMP NO. 612

DRAFT  
NOT FOR BIDDING  
AUGUST 2015

ADDENDUMS / REVISIONS	

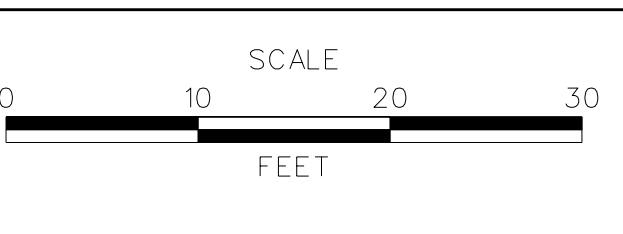

CONTRACT T200811301	BRIDGE NO.
COUNTY NEW CASTLE	DESIGNED BY: JEG
	CHECKED BY: MFM

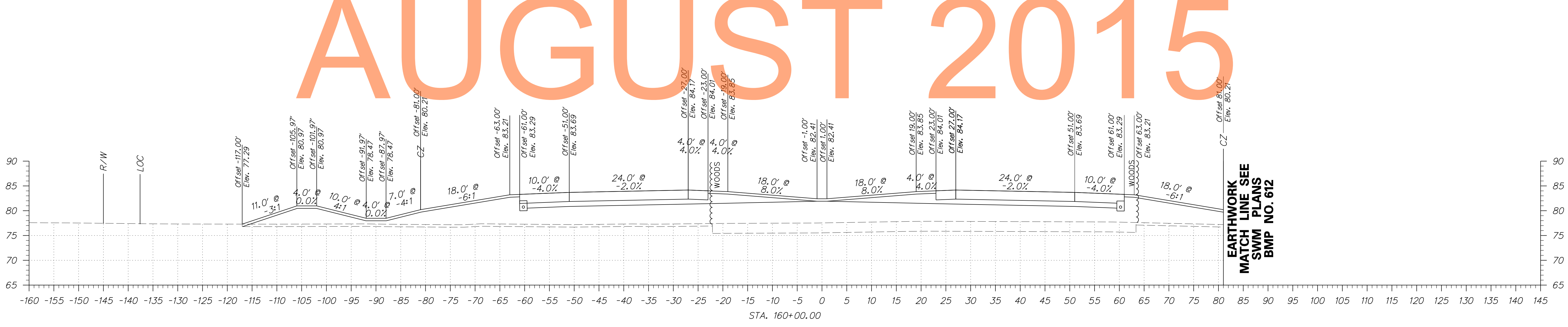
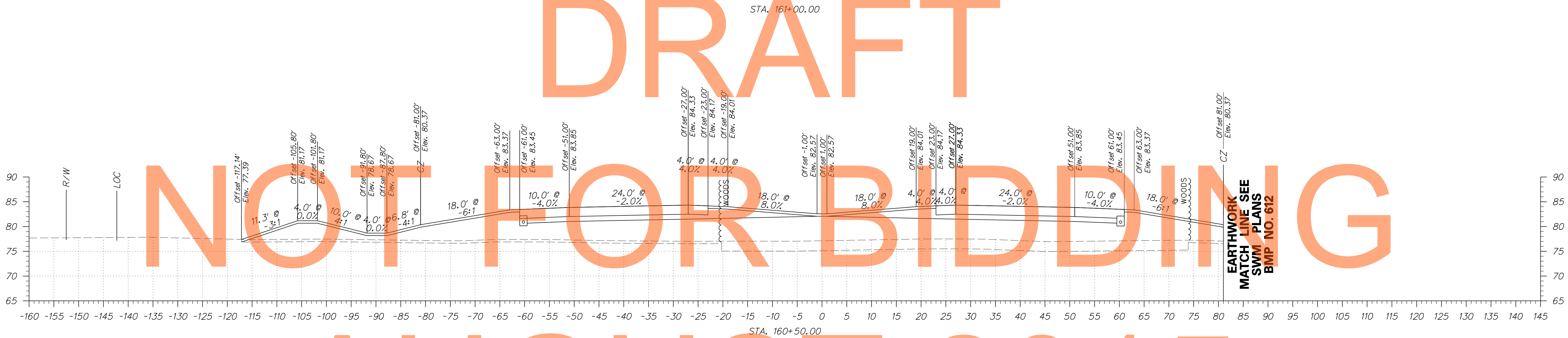
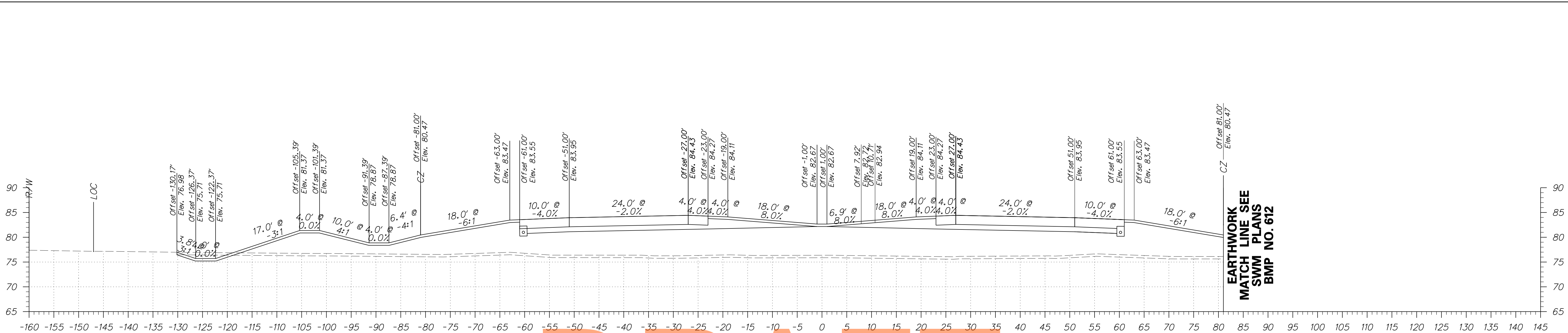

DRAFT

NOT FOR BIDDING

AUGUST 2015

ADDENDUMS / REVISIONS

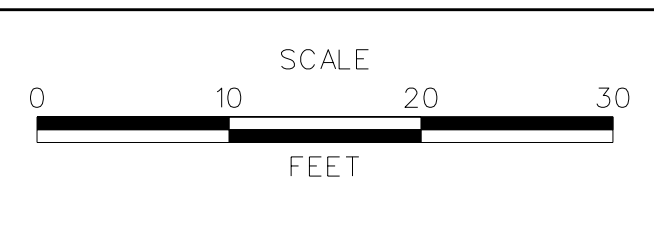

**US 301**  
**MARYLAND STATE LINE**  
**TO LEVELS ROAD**

CONTRACT T200811301	BRIDGE NO.
COUNTY NEW CASTLE	DESIGNED BY: JEG
	CHECKED BY: MFM

**CROSS SECTIONS**  
**US 301 MAINLINE**

SHEET NO. 54
TOTAL SHTS. 539

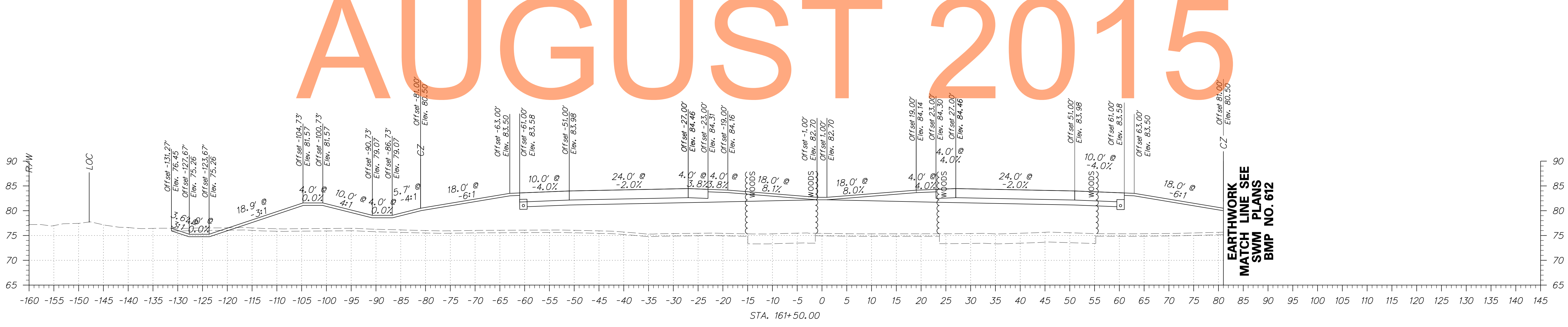
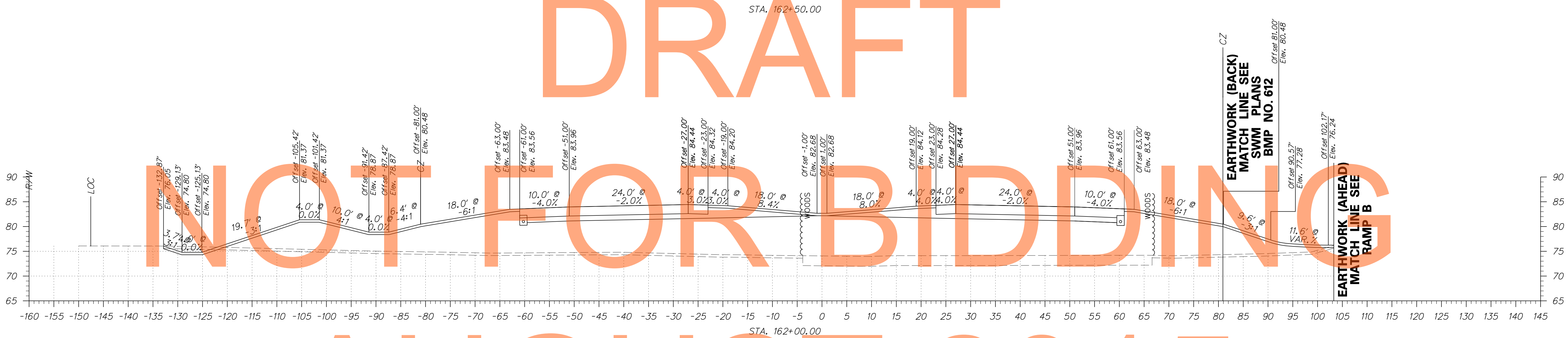
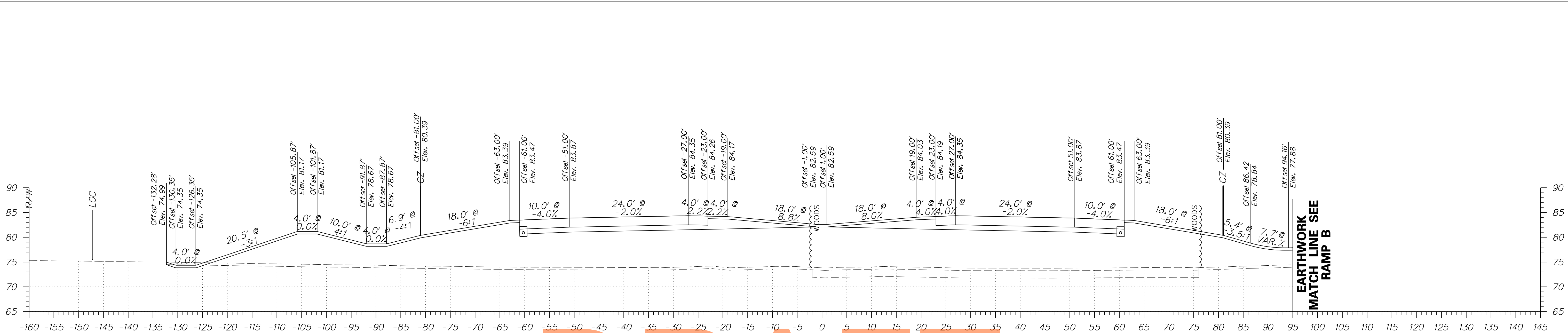

DRAFT

NOT FOR BIDDING

AUGUST 2015

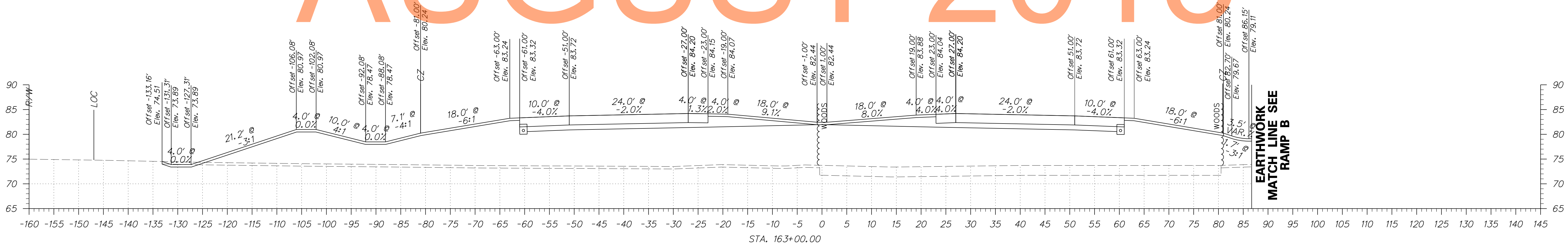
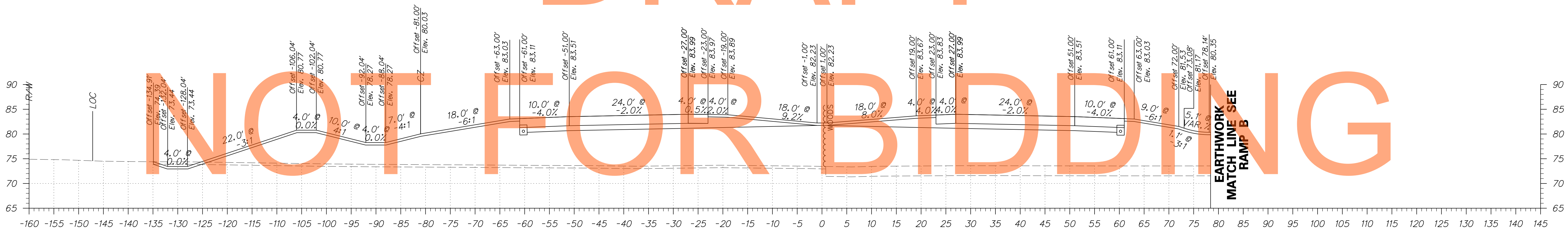
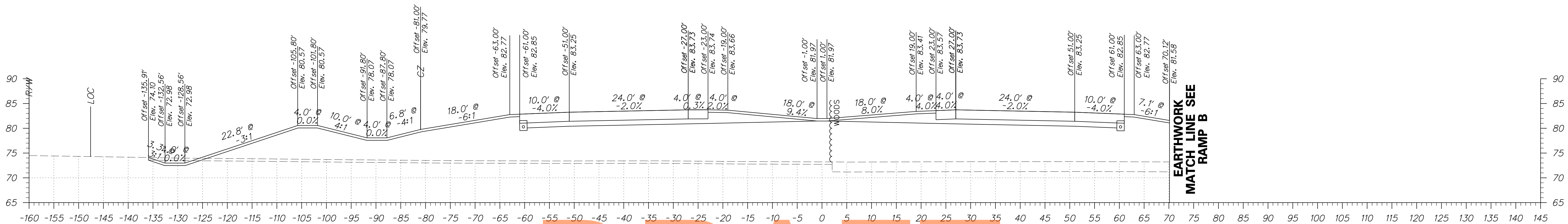

DRAFT

NOT FOR BIDDING

AUGUST 2015



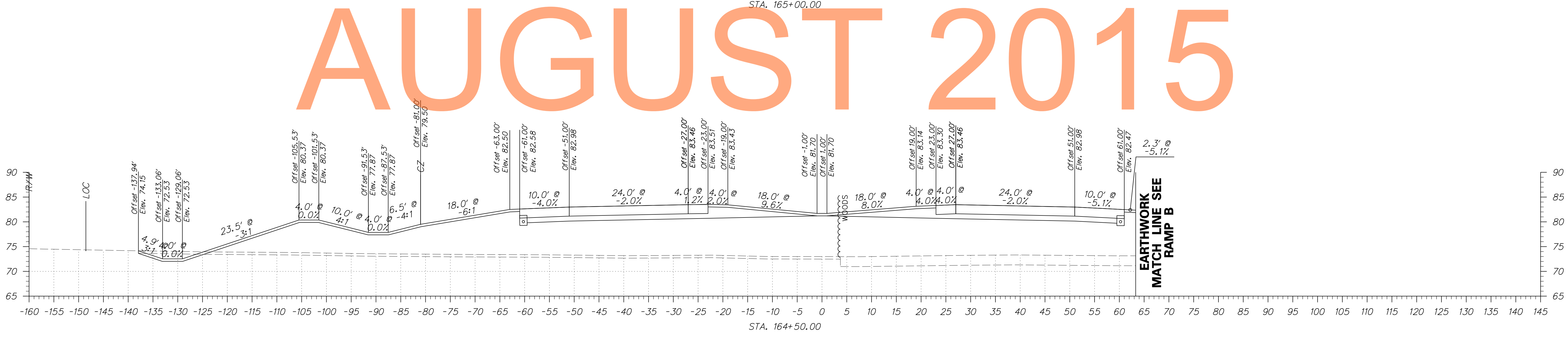
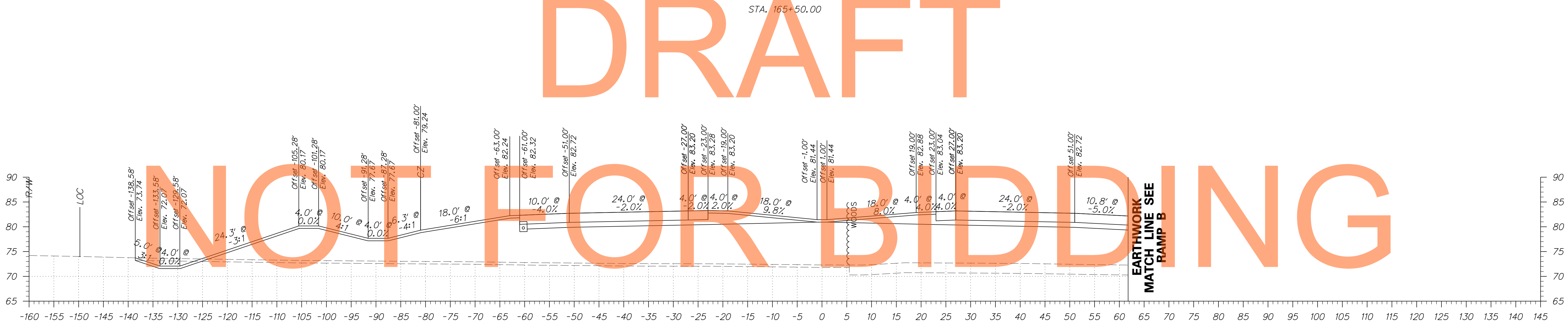
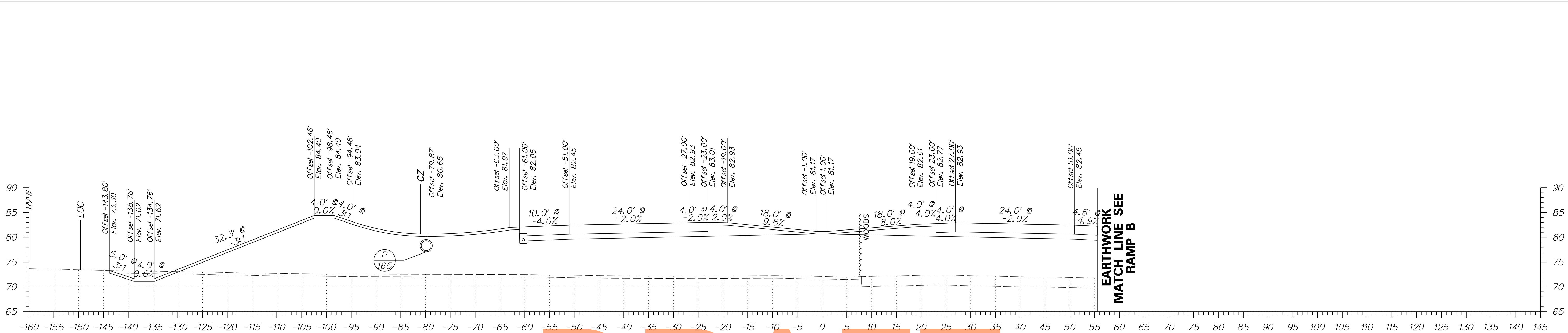

DRAFT  
NOT FOR BIDDING  
AUGUST 2015

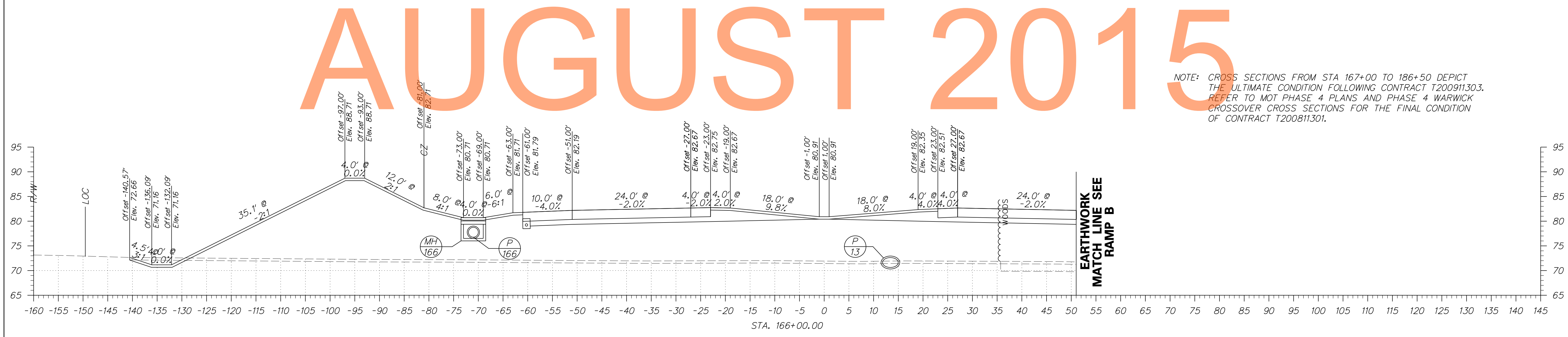
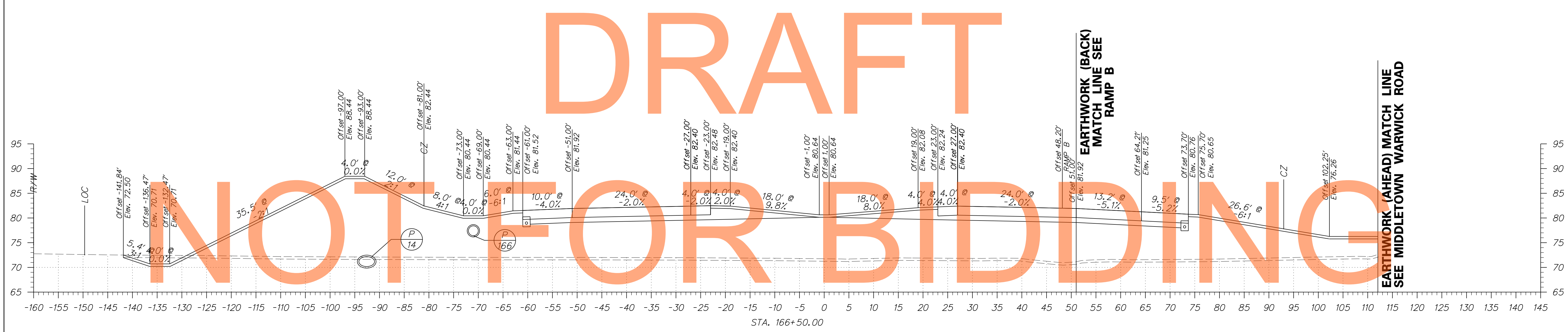
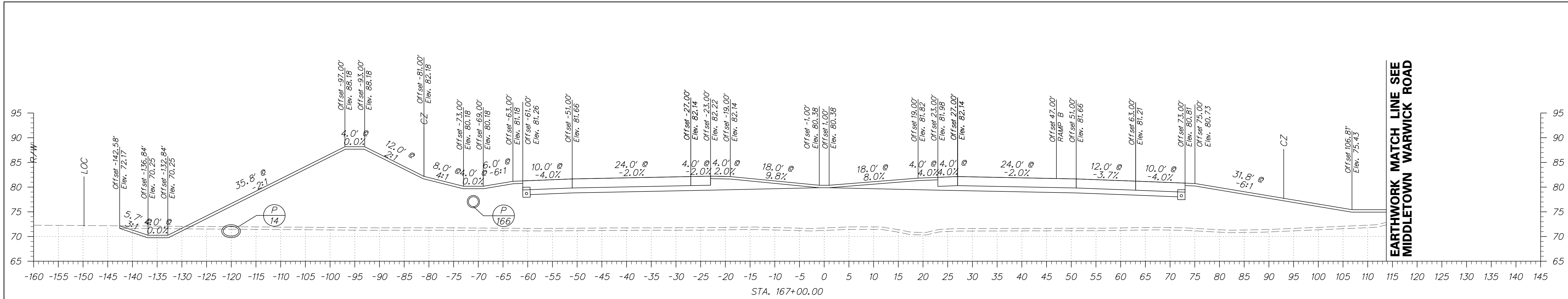

DRAFT

NOT FOR BIDDING

AUGUST 2015

NOTE: CROSS SECTIONS FROM STA 167+00 TO 186+50 DEPICT THE ULTIMATE CONDITION FOLLOWING CONTRACT T200911303. REFER TO MOT PHASE 4 PLANS AND PHASE 4 WARWICK CROSSOVER CROSS SECTIONS FOR THE FINAL CONDITION OF CONTRACT T200811301.

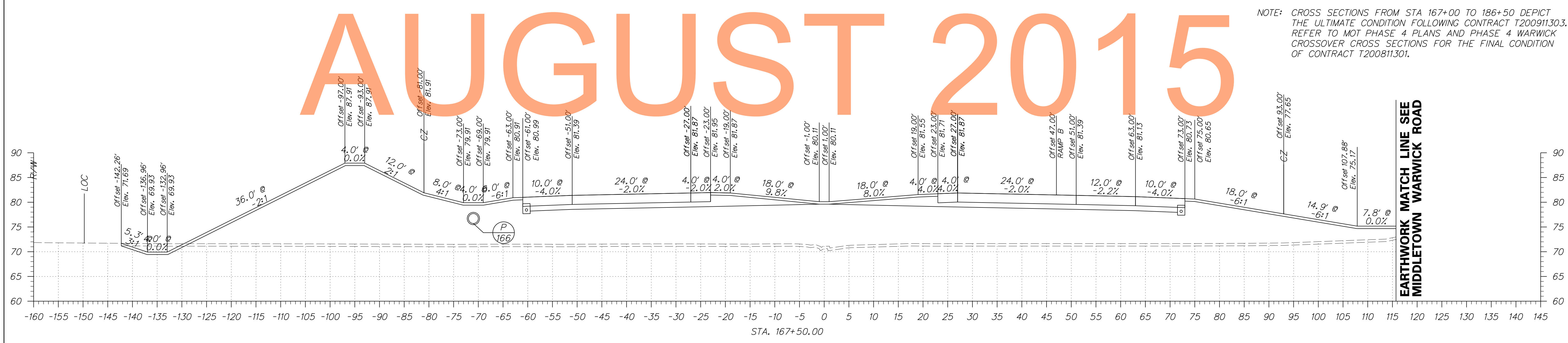
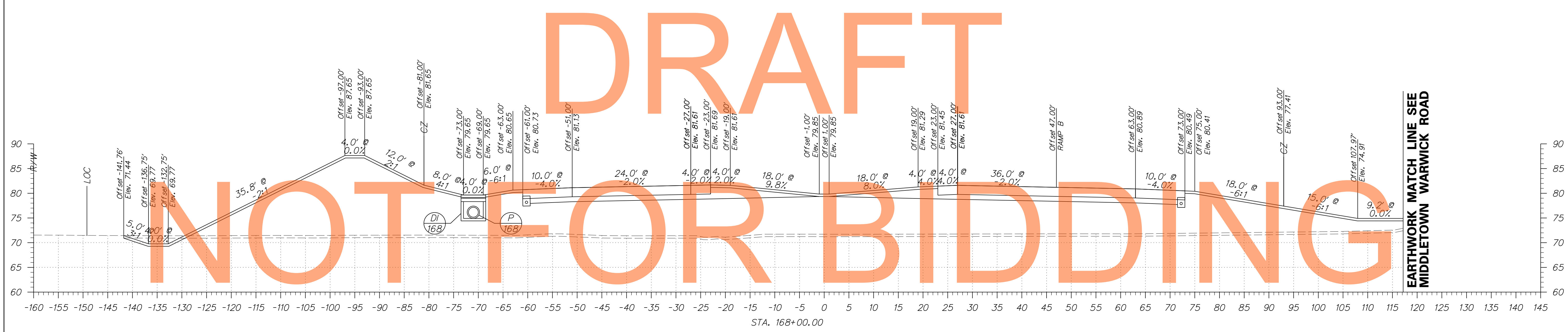
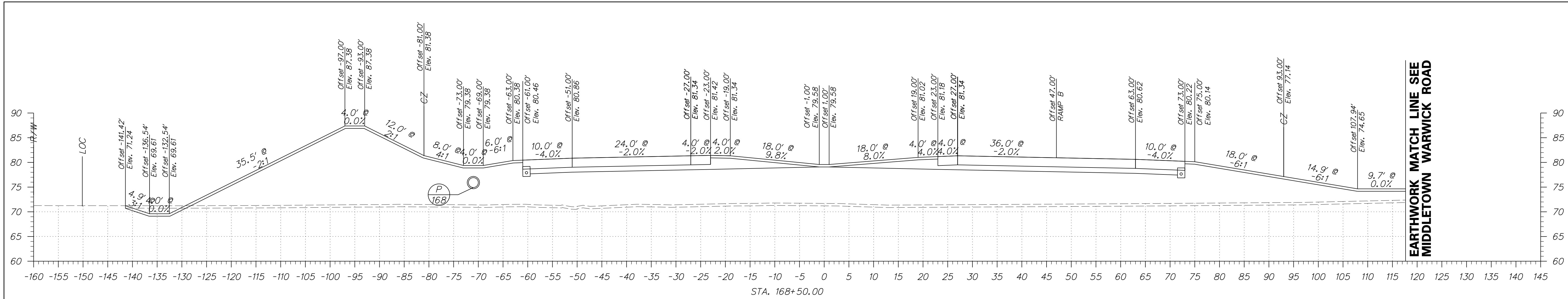

DRAFT

NOT FOR BIDDING

AUGUST 2015

NOTE: CROSS SECTIONS FROM STA 167+00 TO 186+50 DEPICT THE ULTIMATE CONDITION FOLLOWING CONTRACT T200911303. REFER TO MOT PHASE 4 PLANS AND PHASE 4 WARWICK CROSSOVER CROSS SECTIONS FOR THE FINAL CONDITION OF CONTRACT T200811301.

ADDENDUMS / REVISIONS

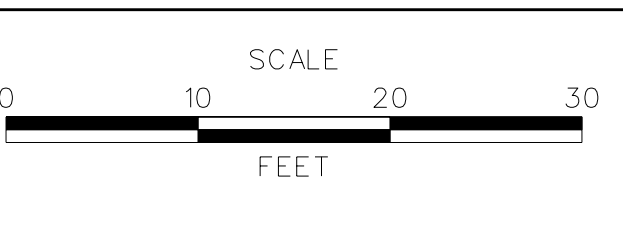

CONTRACT T200811301	BRIDGE NO.
COUNTY NEW CASTLE	DESIGNED BY: JEG
	CHECKED BY: MFM

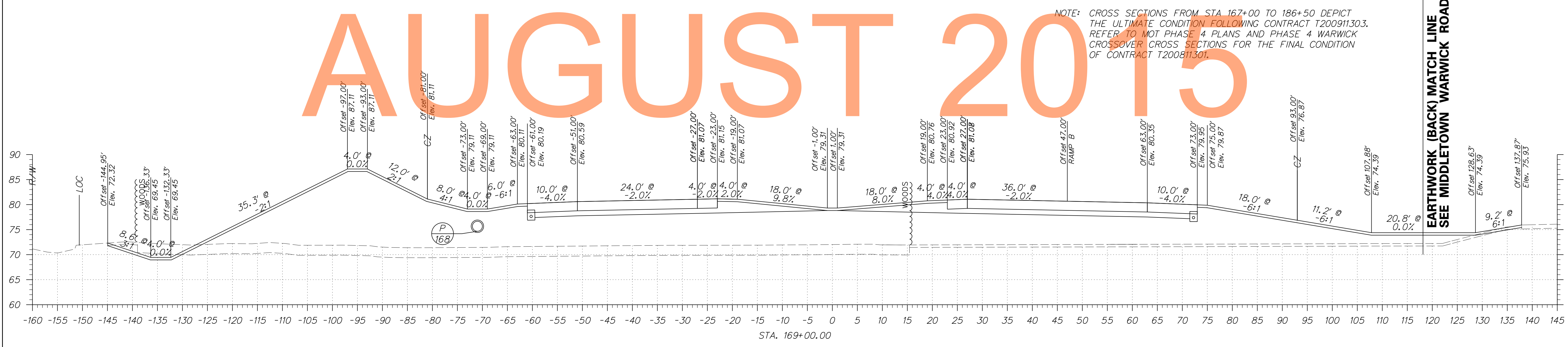
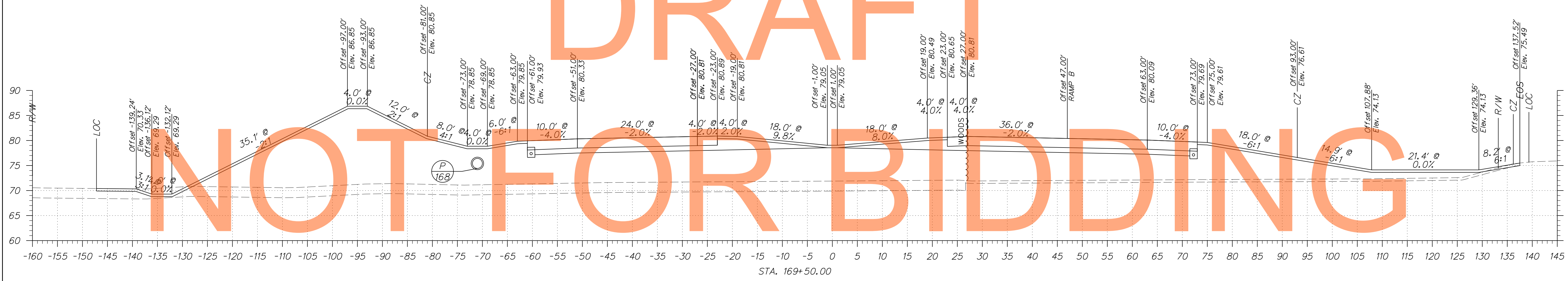
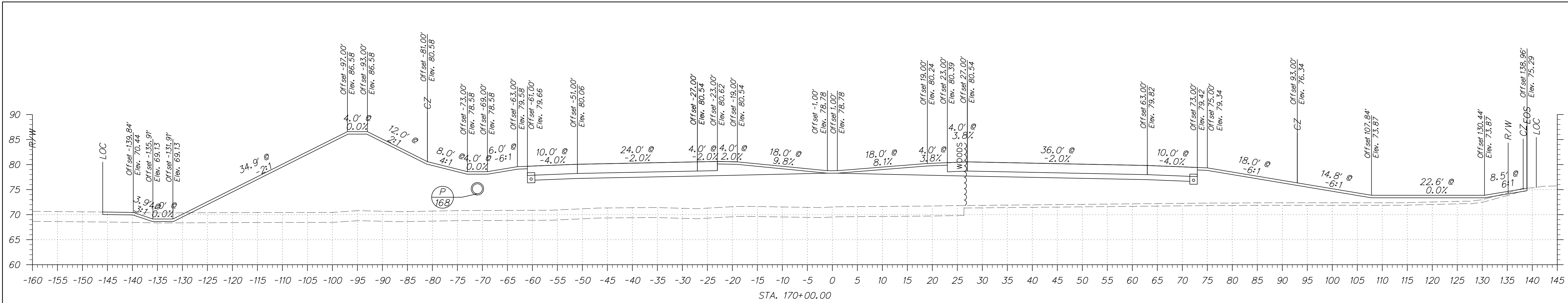

DRAFT

NOT FOR BIDDING

AUGUST 2015

NOTE: CROSS SECTIONS FROM STA 167+00 TO 186+50 DEPICT THE ULTIMATE CONDITION FOLLOWING CONTRACT T20091130.3. REFER TO MOT PHASE 4 PLANS AND PHASE 4 WARWICK CROSSOVER CROSS SECTIONS FOR THE FINAL CONDITION OF CONTRACT T200811301.

EARTHWORK (BACK) MATCH LINE SEE MIDDLETOWN WARWICK ROAD



ADDENDUMS / REVISIONS	

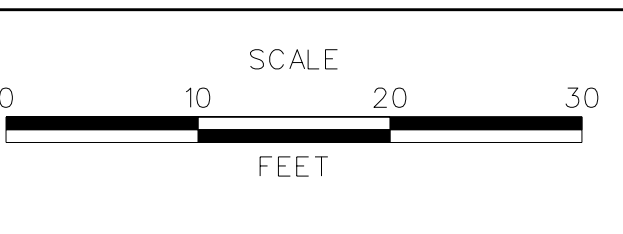

**US 301  
MARYLAND STATE LINE  
TO LEVELS ROAD**

CONTRACT T200811301	BRIDGE NO.
COUNTY NEW CASTLE	DESIGNED BY: JEG
	CHECKED BY: MFM

<b>CROSS SECTIONS US 301 MAINLINE</b>	
SHEET NO.	60
TOTAL SHTS.	539

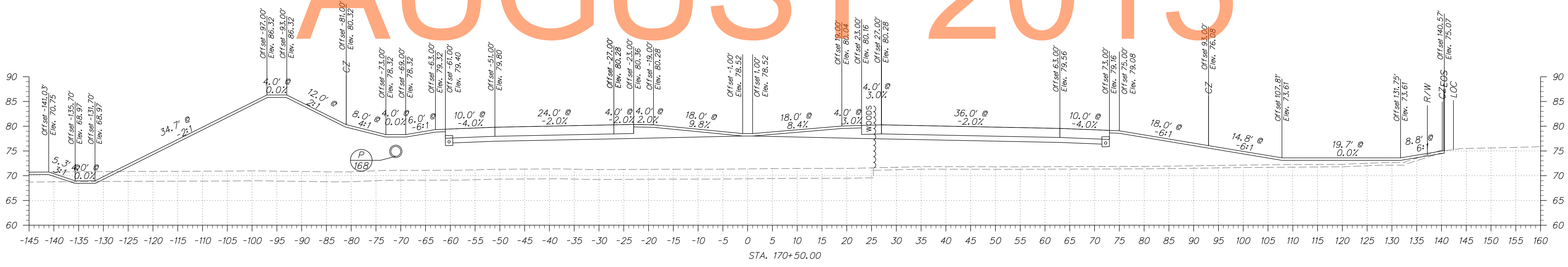
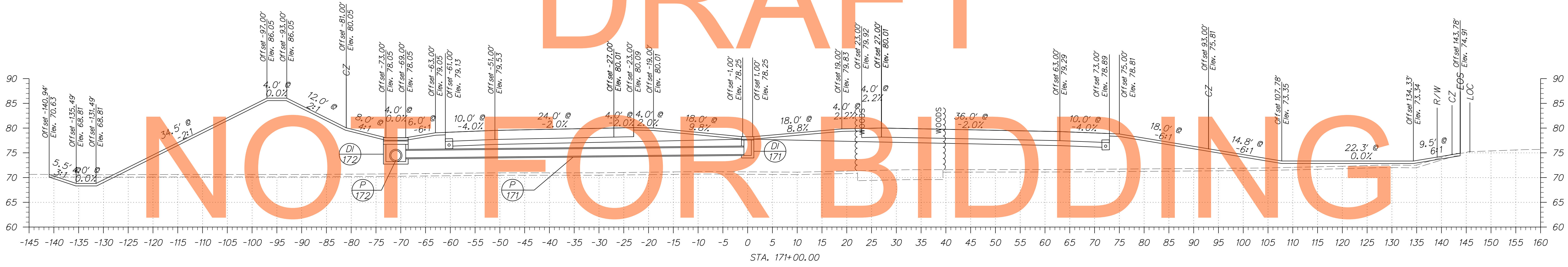
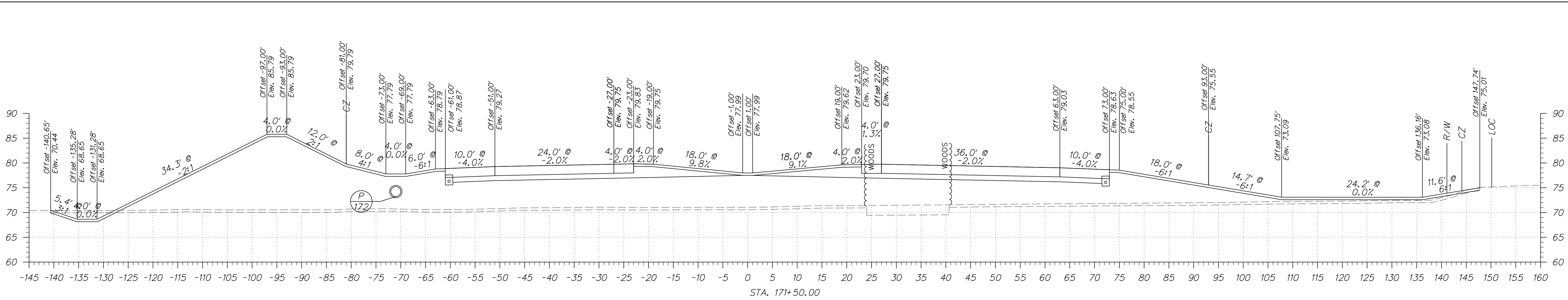

DRAFT  
NOT FOR BIDDING  
AUGUST 2015

NOTE: CROSS SECTIONS FROM STA 167+00 TO 186+50 DEPICT THE ULTIMATE CONDITION FOLLOWING CONTRACT T200911303. REFER TO MOT PHASE 4 PLANS AND PHASE 4 WARWICK CROSSOVER CROSS SECTION FOR THE FINAL CONDITION OF CONTRACT T200811301.

ADDENDUMS / REVISIONS

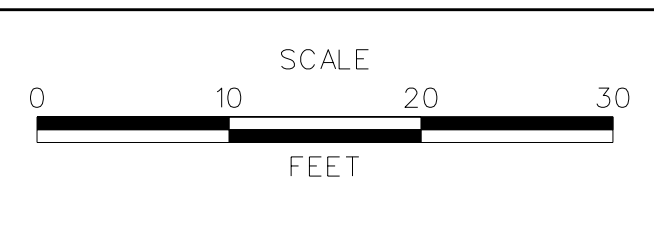

**US 301**  
**MARYLAND STATE LINE**  
**TO LEVELS ROAD**

CONTRACT T200811301	BRIDGE NO.
COUNTY NEW CASTLE	DESIGNED BY: JEG
	CHECKED BY: MFM

<b>CROSS SECTIONS</b> <b>US 301 MAINLINE</b>	SHEET NO. 61
	TOTAL SHTS. 539

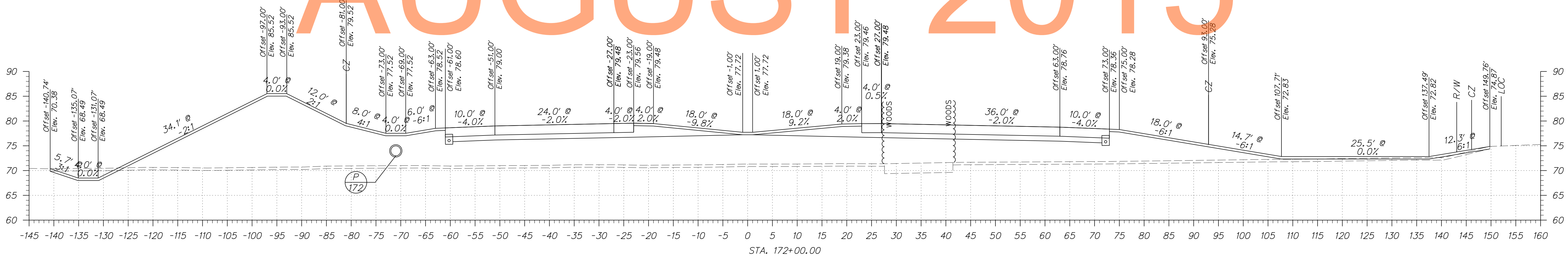
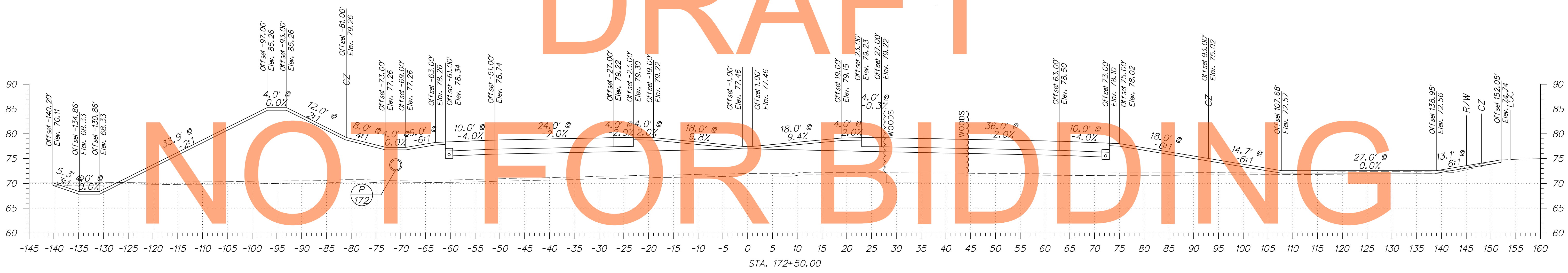
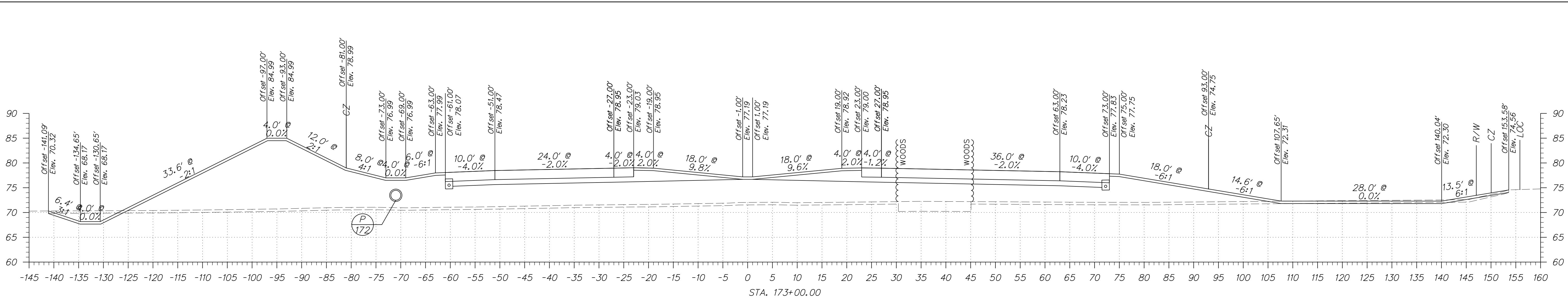

DRAFT

NOT FOR BIDDING

AUGUST 2015

NOTE: CROSS SECTIONS FROM STA 167+00 TO 186+50 DEPICT THE ULTIMATE CONDITION FOLLOWING CONTRACT T200911303. REFER TO MOT PHASE 4 PLANS AND PHASE 4 WARWICK CROSSOVER CROSS SECTIONS FOR THE FINAL CONDITION OF CONTRACT T200811301.

ADDENDUMS / REVISIONS

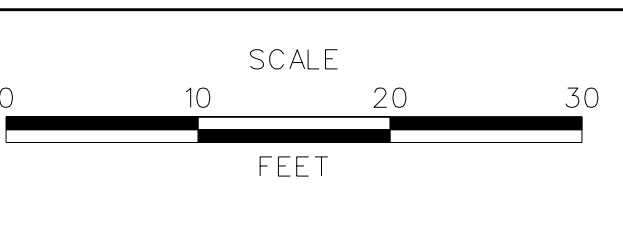

CONTRACT T200811301	BRIDGE NO.
COUNTY NEW CASTLE	DESIGNED BY: JEG
	CHECKED BY: MFM

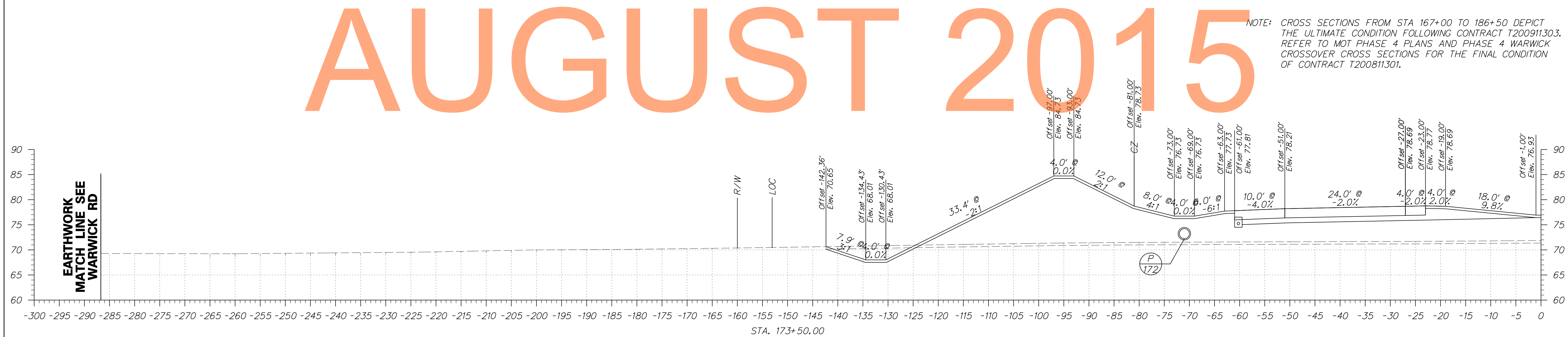
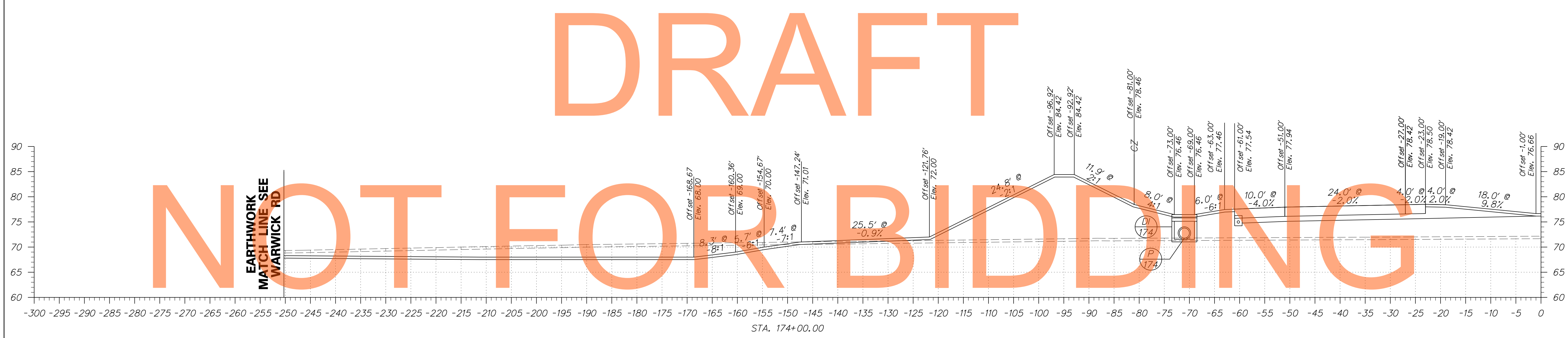
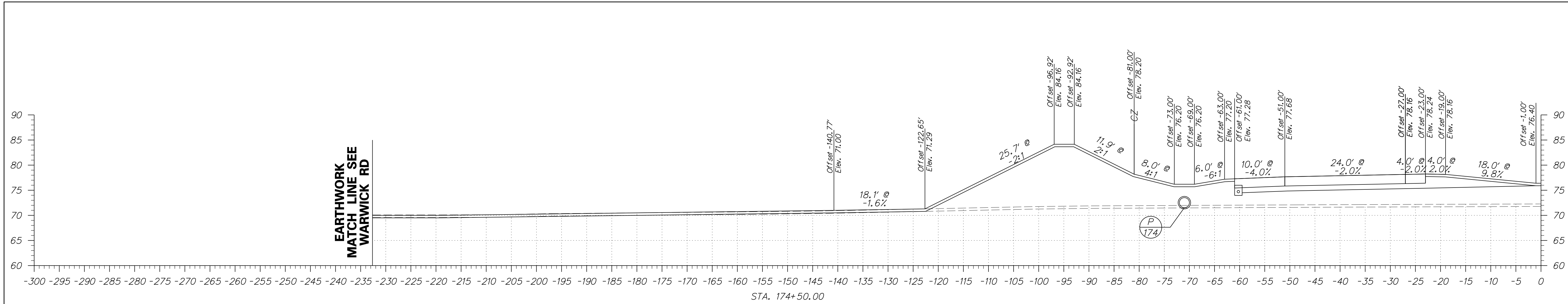

DRAFT  
NOT FOR BIDDING  
AUGUST 2015

NOTE: CROSS SECTIONS FROM STA 167+00 TO 186+50 DEPICT THE ULTIMATE CONDITION FOLLOWING CONTRACT T200911303. REFER TO MOT PHASE 4 PLANS AND PHASE 4 WARWICK CROSSOVER CROSS SECTIONS FOR THE FINAL CONDITION OF CONTRACT T200811301.

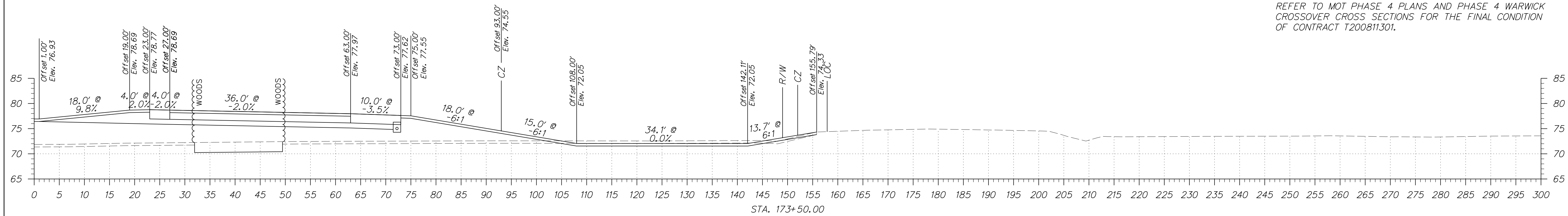
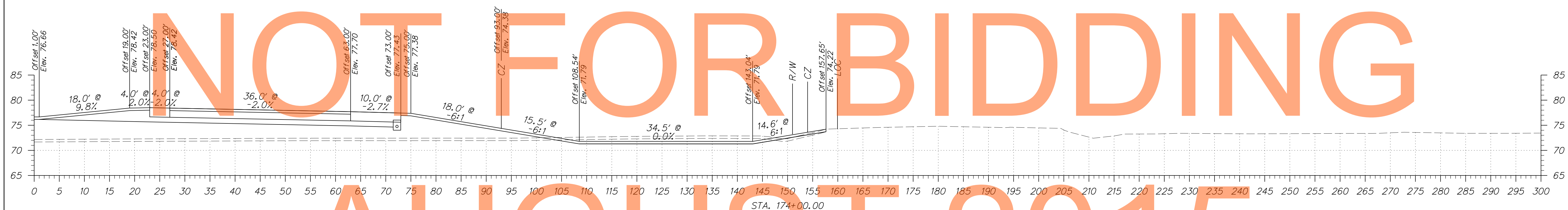
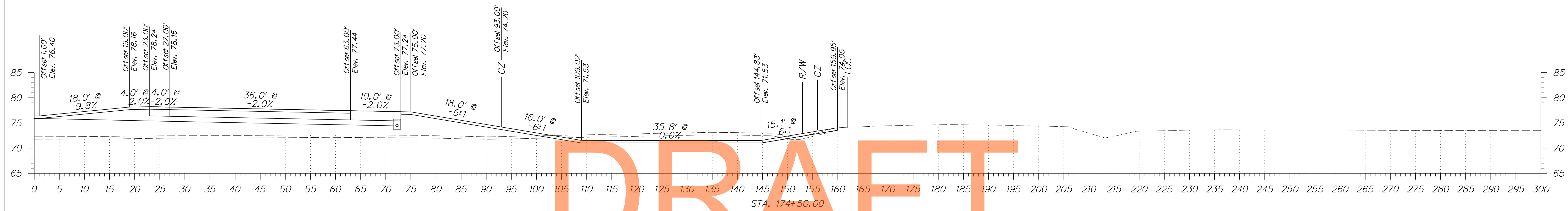

NOTE: CROSS SECTIONS FROM STA 167+00 TO 186+50 DEPICT THE ULTIMATE CONDITION FOLLOWING CONTRACT T200911303. REFER TO MOT PHASE 4 PLANS AND PHASE 4 WARWICK CROSSOVER CROSS SECTIONS FOR THE FINAL CONDITION OF CONTRACT T200811301.

ADDENDUMS / REVISIONS	

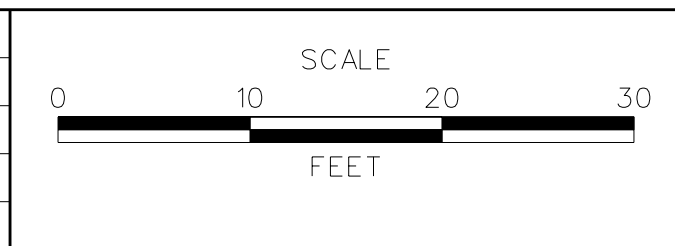

**US 301**  
**MARYLAND STATE LINE**  
**TO LEVELS ROAD**

CONTRACT T200811301	BRIDGE NO. 
COUNTY NEW CASTLE	DESIGNED BY: JEG
	CHECKED BY: MFM

<b>CROSS SECTIONS</b> <b>US 301 MAINLINE</b>	SHEET NO. 64
	TOTAL SHTS. 539



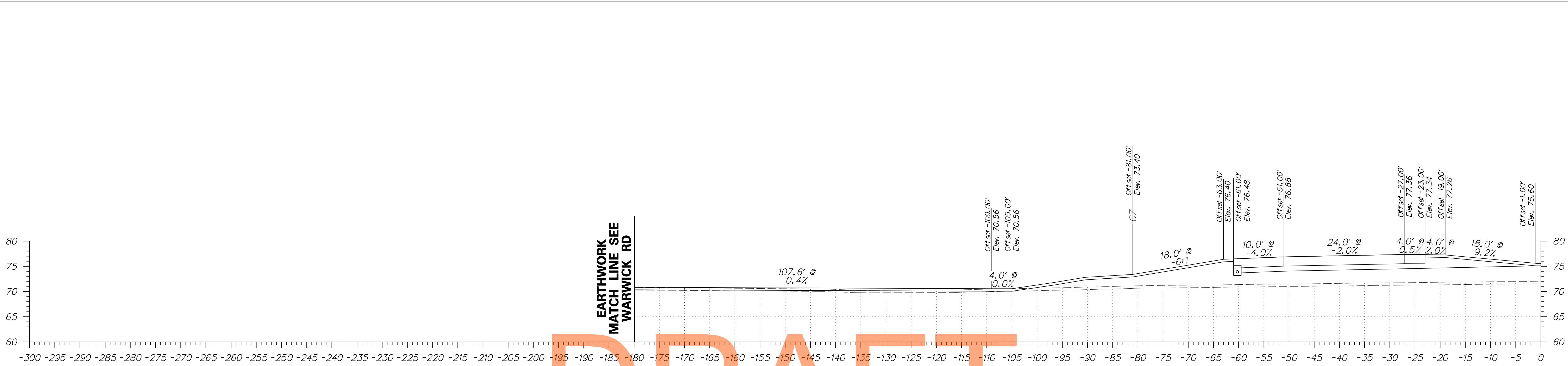

DRAFT

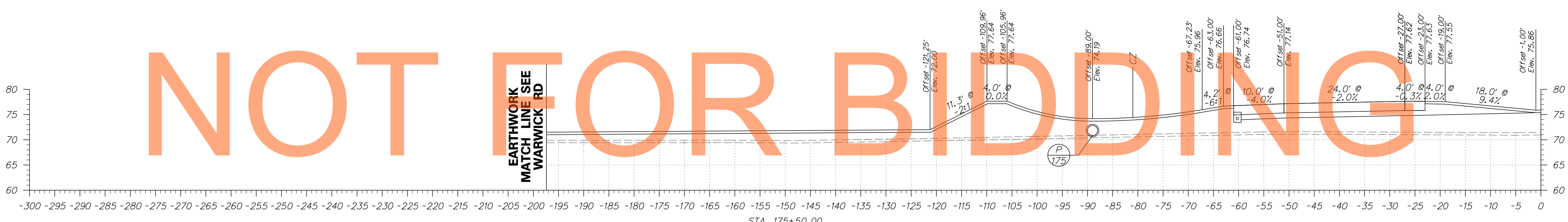

NOT FOR BIDDING

AUGUST 2015

NOTE: CROSS SECTIONS FROM STA 167+00 TO 186+50 DEPICT THE ULTIMATE CONDITION FOLLOWING CONTRACT T200911303. REFER TO MOT PHASE 4 PLANS AND PHASE 4 WARWICK CROSSOVER CROSS SECTIONS FOR THE FINAL CONDITION OF CONTRACT T200811301.

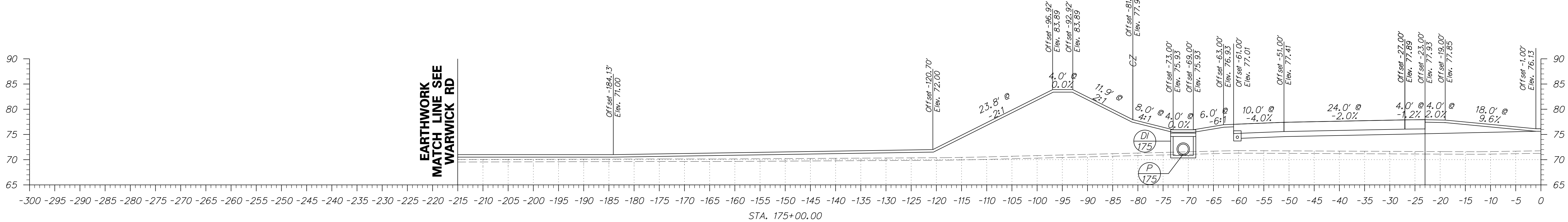

ADDENDUMS / REVISIONS	

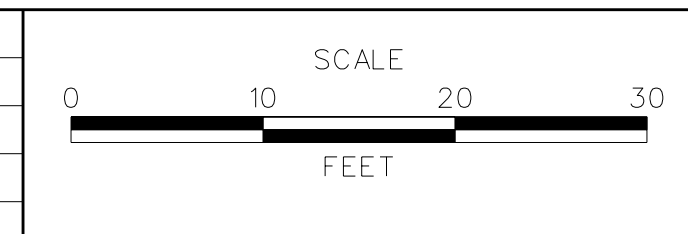

**US 301  
MARYLAND STATE LINE  
TO LEVELS ROAD**

CONTRACT T200811301	BRIDGE NO.
COUNTY NEW CASTLE	DESIGNED BY: JEG
	CHECKED BY: MFM

<b>CROSS SECTIONS US 301 MAINLINE</b>
SHEET NO. 65
TOTAL SHTS. 539

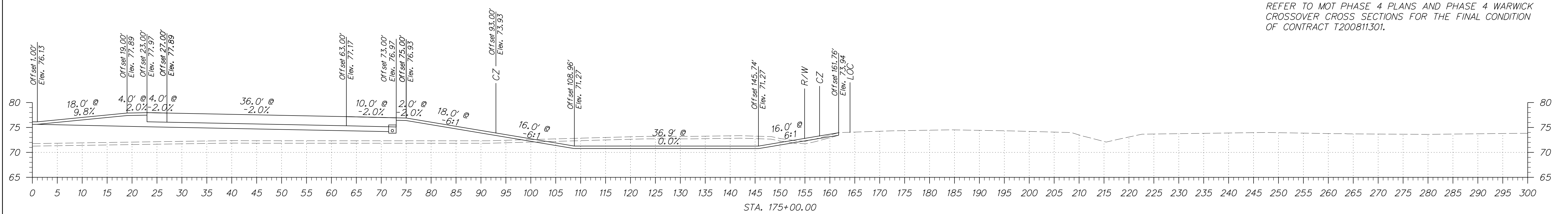
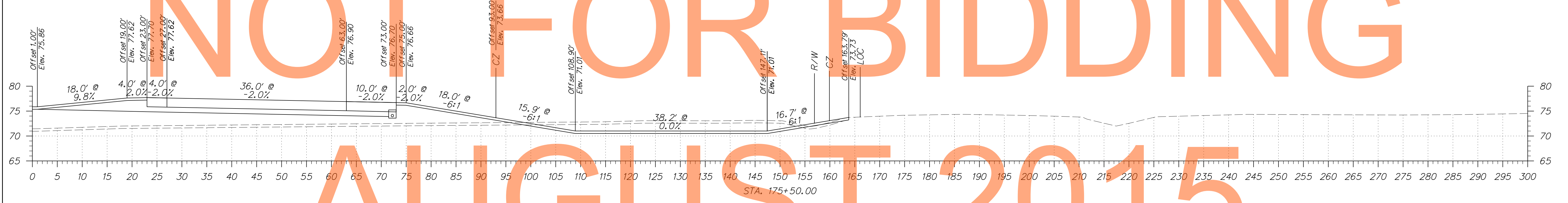
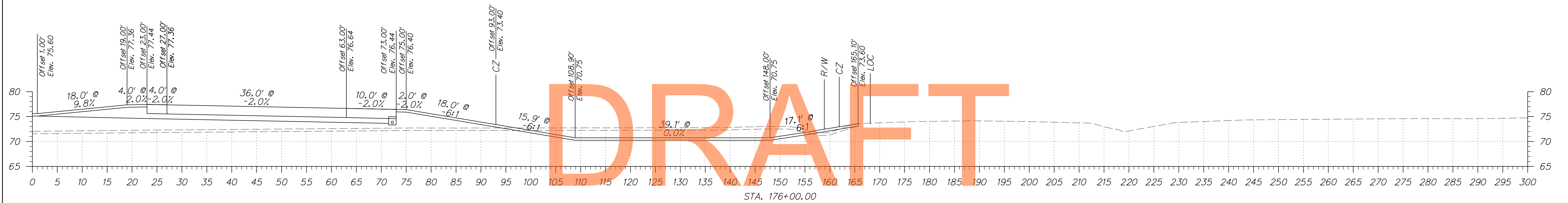

DRAFT

NOT FOR BIDDING

AUGUST 2015

NOTE: CROSS SECTIONS FROM STA 167+00 TO 186+50 DEPICT THE ULTIMATE CONDITION FOLLOWING CONTRACT T200911303. REFER TO MOT PHASE 4 PLANS AND PHASE 4 WARWICK CROSSOVER CROSS SECTIONS FOR THE FINAL CONDITION OF CONTRACT T200811301.

ADDENDUMS / REVISIONS	

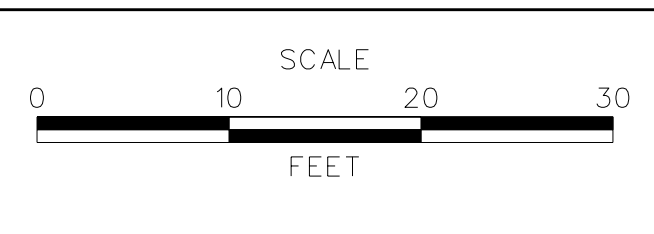

CONTRACT T200811301	BRIDGE NO.
COUNTY NEW CASTLE	DESIGNED BY: JEG
	CHECKED BY: MFM

DRAFT

NOT FOR BIDDING

AUGUST 2015

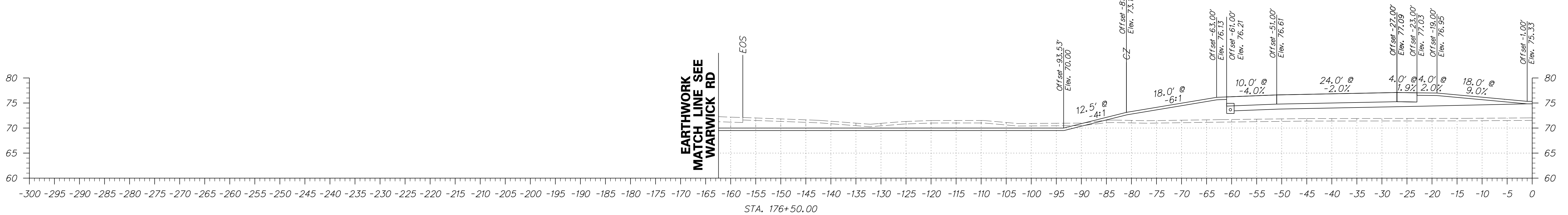
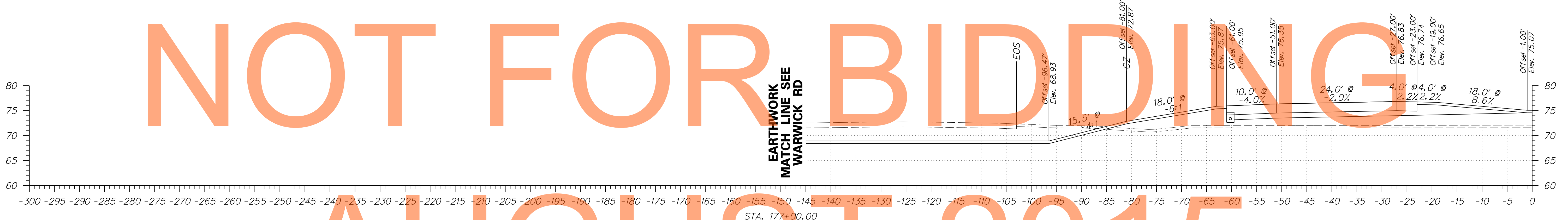
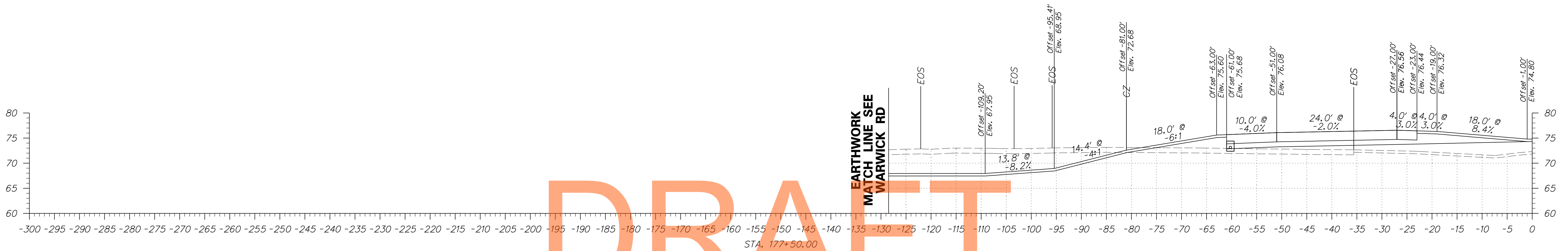

NOTE: CROSS SECTIONS FROM STA 167+00 TO 186+50 DEPICT THE ULTIMATE CONDITION FOLLOWING CONTRACT T20091130.3. REFER TO MOT PHASE 4 PLANS AND PHASE 4 WARWICK CROSSOVER CROSS SECTIONS FOR THE FINAL CONDITION OF CONTRACT T20081130.1.



ADDENDUMS / REVISIONS	

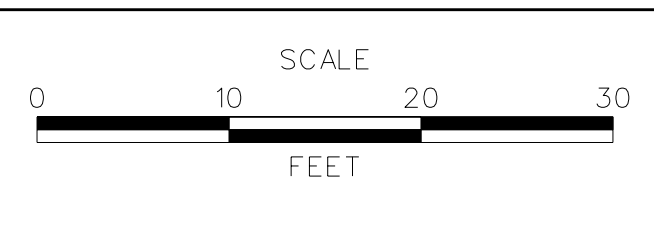

**US 301  
MARYLAND STATE LINE  
TO LEVELS ROAD**

CONTRACT T200811301	BRIDGE NO.
COUNTY NEW CASTLE	DESIGNED BY: JEG
	CHECKED BY: MFM

<b>CROSS SECTIONS US 301 MAINLINE</b>	SHEET NO. 67
	TOTAL SHTS. 539

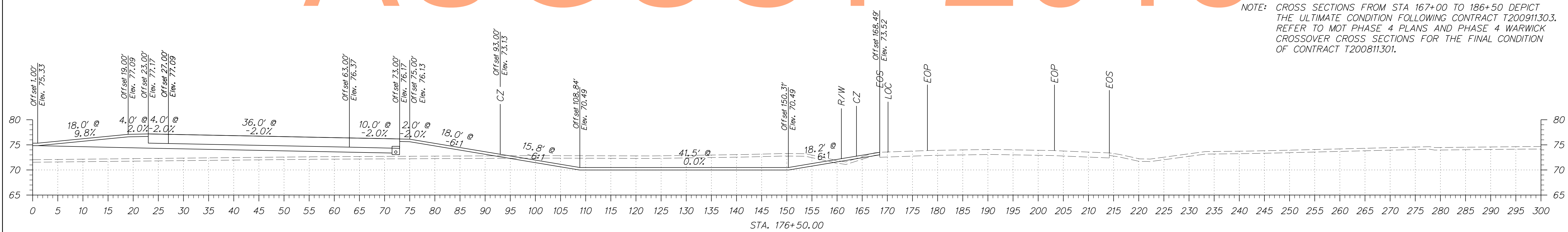
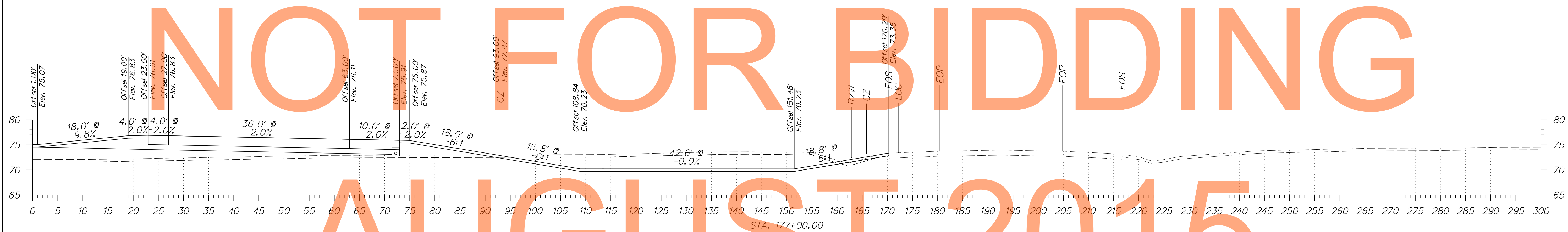
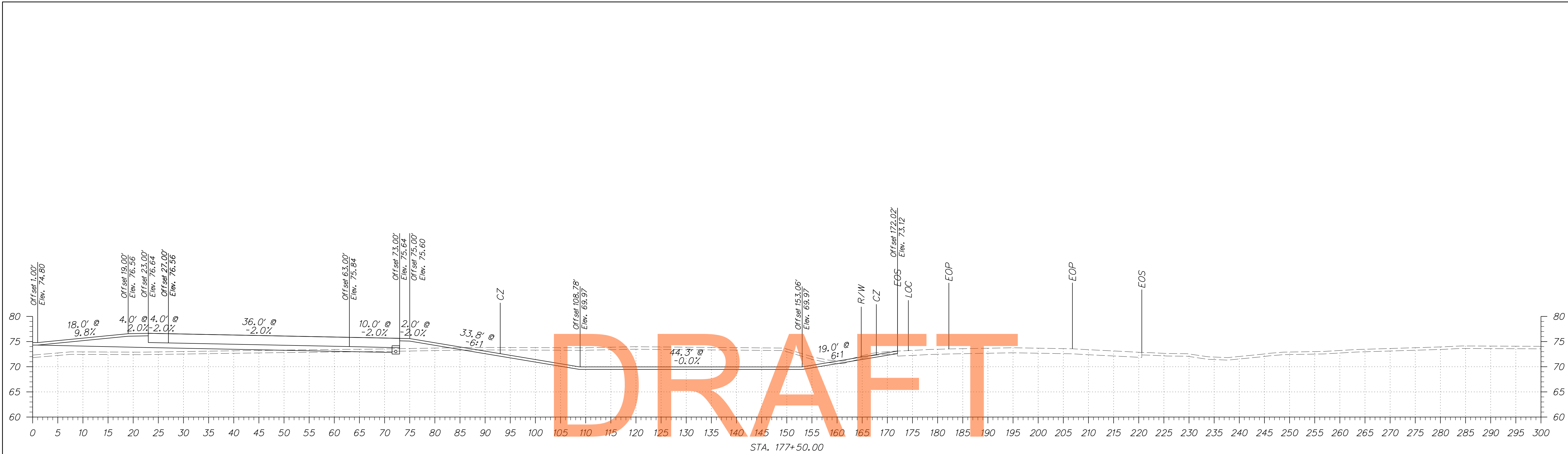

DRAFT

NOT FOR BIDDING

AUGUST 2015

NOTE: CROSS SECTIONS FROM STA 167+00 TO 186+50 DEPICT THE ULTIMATE CONDITION FOLLOWING CONTRACT T200911303. REFER TO MOT PHASE 4 PLANS AND PHASE 4 WARWICK CROSSOVER CROSS SECTIONS FOR THE FINAL CONDITION OF CONTRACT T200811301.

EARTHWORK  
MATCH LINE SEE  
WARWICK RD

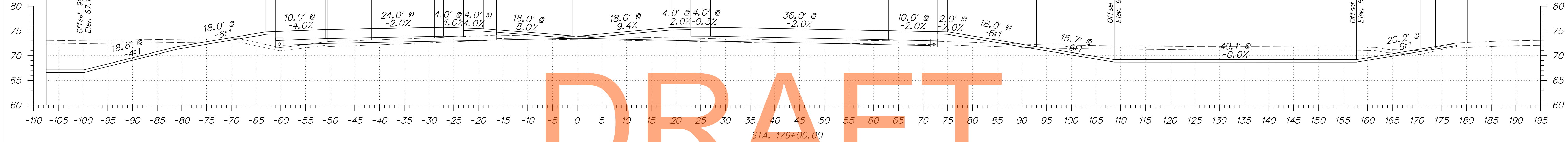

DRAFT

EARTHWORK  
MATCH LINE SEE  
WARWICK RD

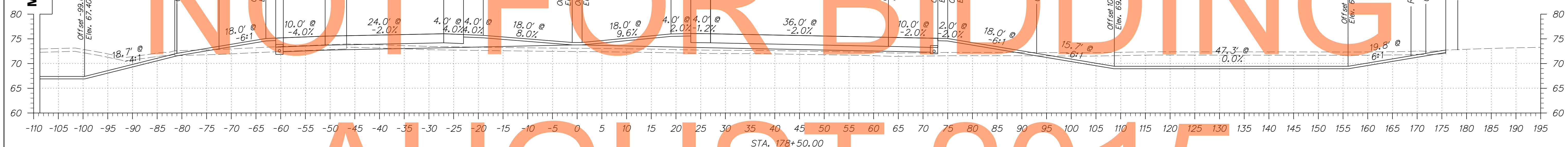

AUGUST 2015

NOTE: CROSS SECTIONS FROM STA 167+00 TO 186+50 DEPICT THE ULTIMATE CONDITION FOLLOWING CONTRACT T200911303. REFER TO MOT PHASE 4 PLANS AND PHASE 4 WARWICK CROSSOVER CROSS SECTIONS FOR THE FINAL CONDITION OF CONTRACT T200811301.

EARTHWORK  
MATCH LINE SEE  
WARWICK RD

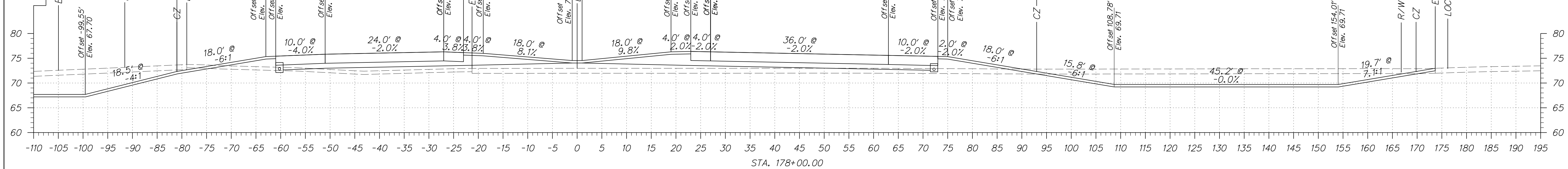

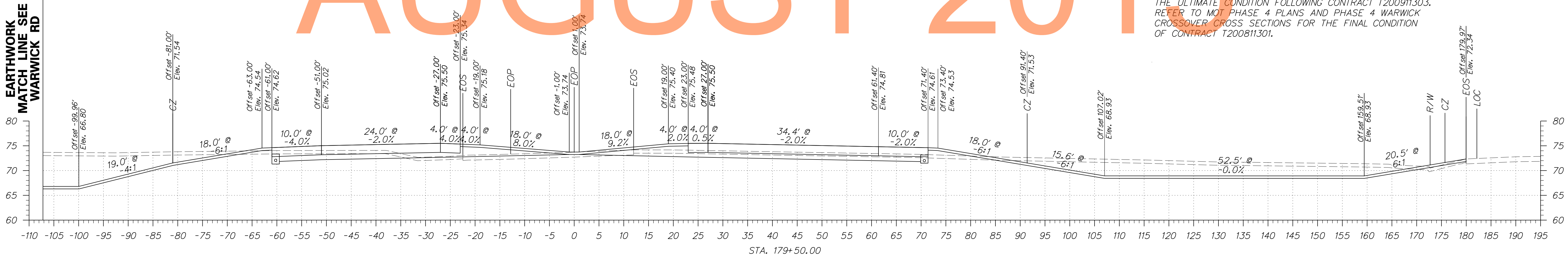
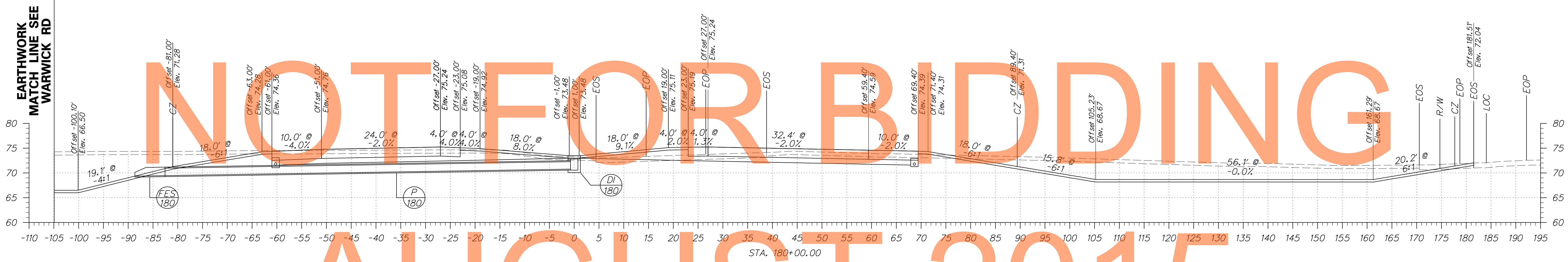
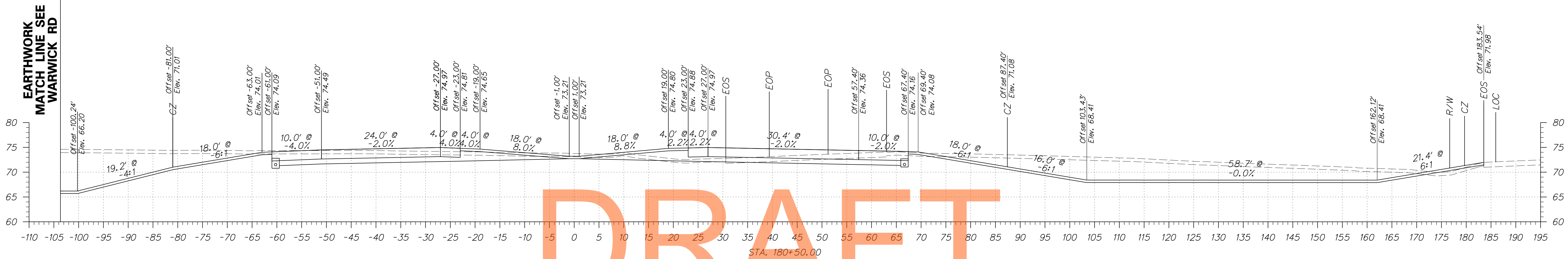

DRAFT

NOT FOR BIDDING

AUGUST 2015

NOTE: CROSS SECTIONS FROM STA 167+00 TO 186+50 DEPICT THE ULTIMATE CONDITION FOLLOWING CONTRACT T200911303. REFER TO MOT PHASE 4 PLANS AND PHASE 4 WARWICK CROSSOVER CROSS SECTIONS FOR THE FINAL CONDITION OF CONTRACT T200811301.

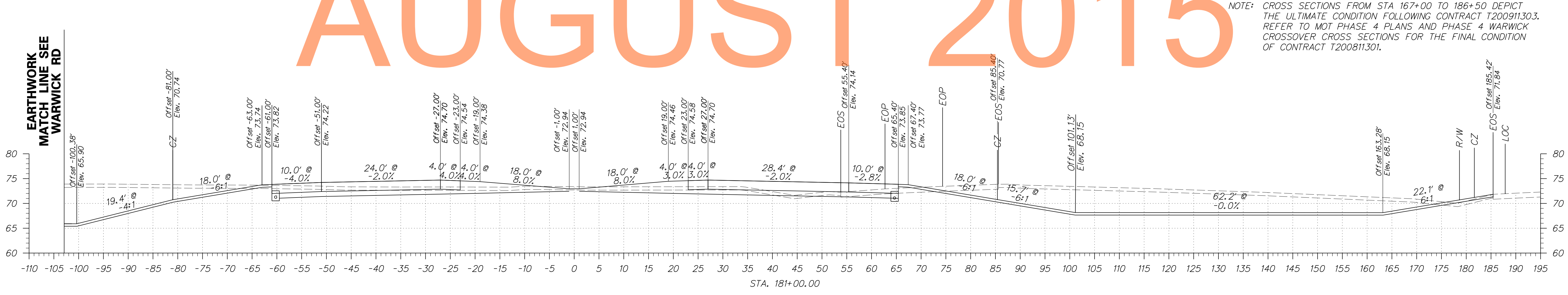
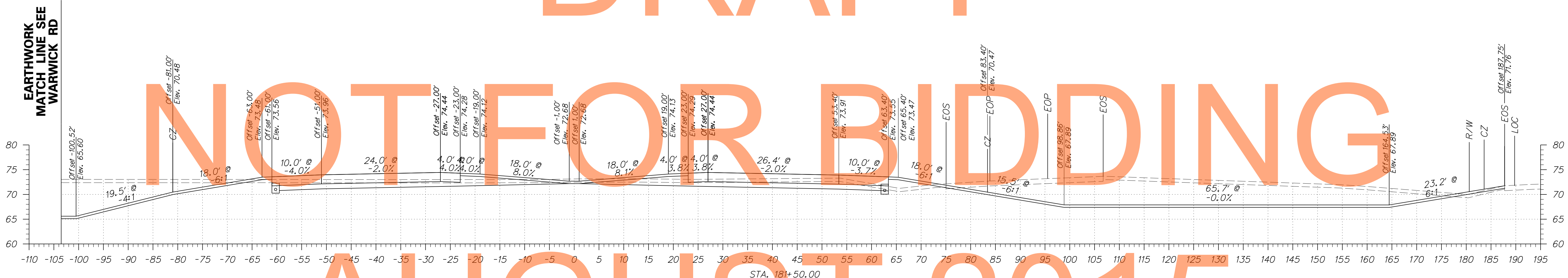
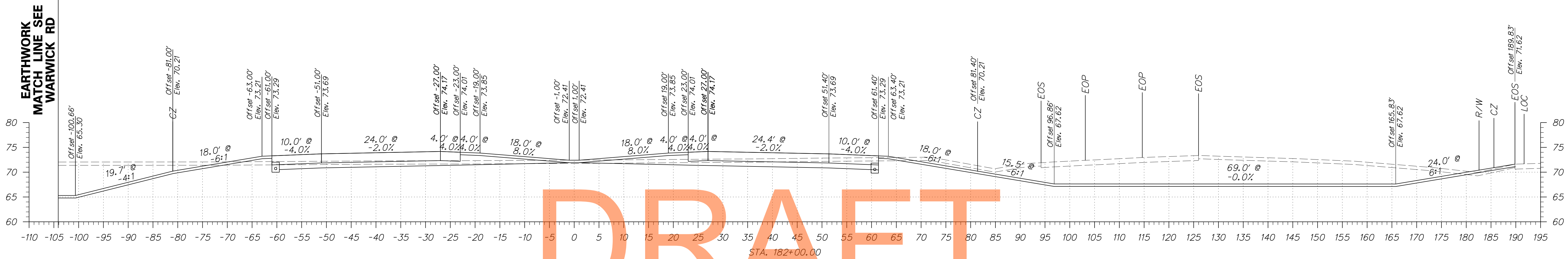

DRAFT

NOT FOR BIDDING

AUGUST 2015

NOTE: CROSS SECTIONS FROM STA 167+00 TO 186+50 DEPICT THE ULTIMATE CONDITION FOLLOWING CONTRACT T200911303. REFER TO MOT PHASE 4 PLANS AND PHASE 4 WARWICK CROSSOVER CROSS SECTIONS FOR THE FINAL CONDITION OF CONTRACT T200811301.

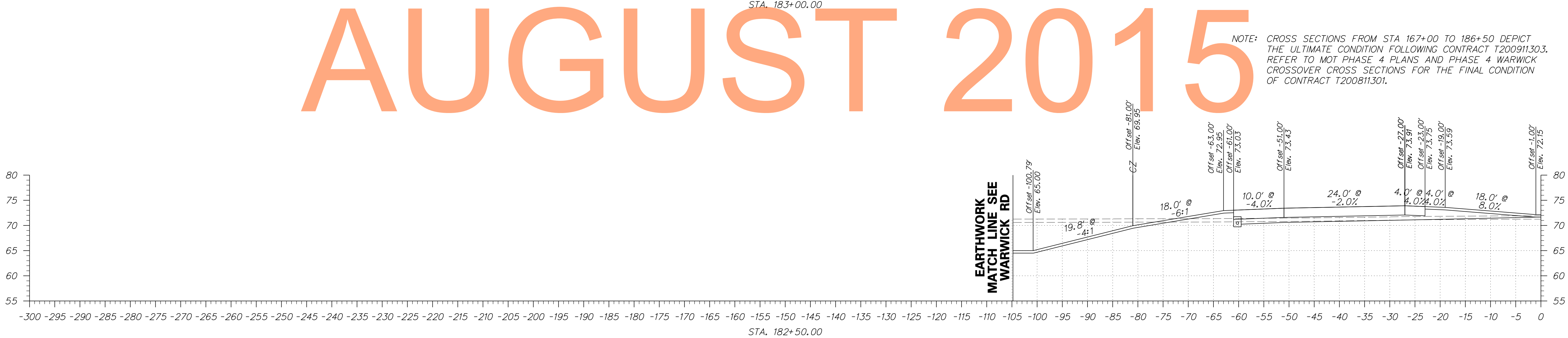
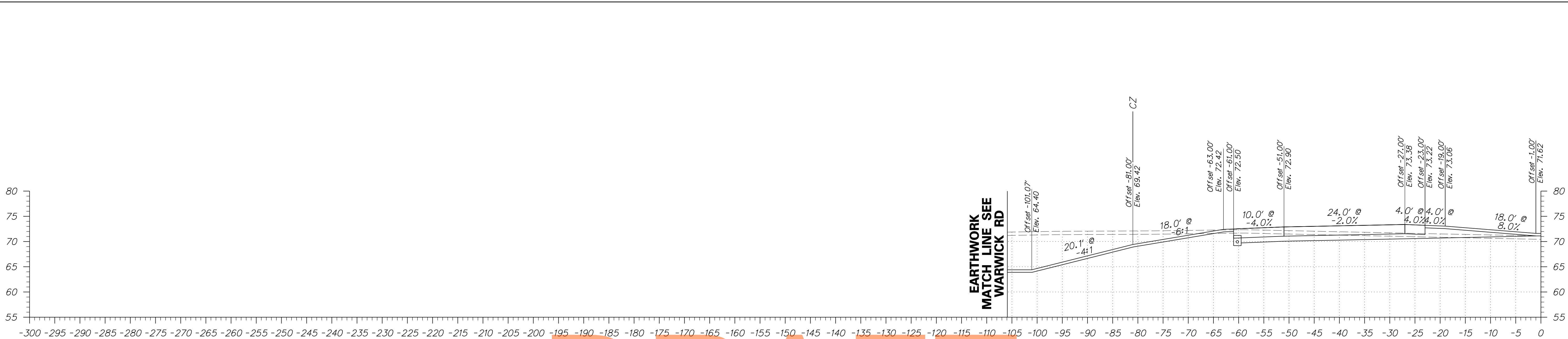

DRAFT

NOT FOR BIDDING

AUGUST 2015

NOTE: CROSS SECTIONS FROM STA 167+00 TO 186+50 DEPICT THE ULTIMATE CONDITION FOLLOWING CONTRACT T200911303. REFER TO MOT PHASE 4 PLANS AND PHASE 4 WARWICK CROSSOVER CROSS SECTIONS FOR THE FINAL CONDITION OF CONTRACT T200811301.



ADDENDUMS / REVISIONS	

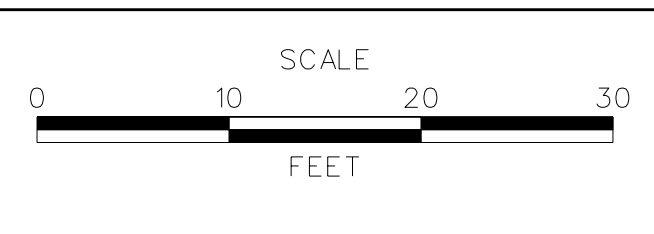

**US 301  
MARYLAND STATE LINE  
TO LEVELS ROAD**

CONTRACT T200811301	BRIDGE NO.
COUNTY NEW CASTLE	DESIGNED BY: JEG
	CHECKED BY: MFM

<b>CROSS SECTIONS US 301 MAINLINE</b>	SHEET NO. 72
	TOTAL SHTS. 539



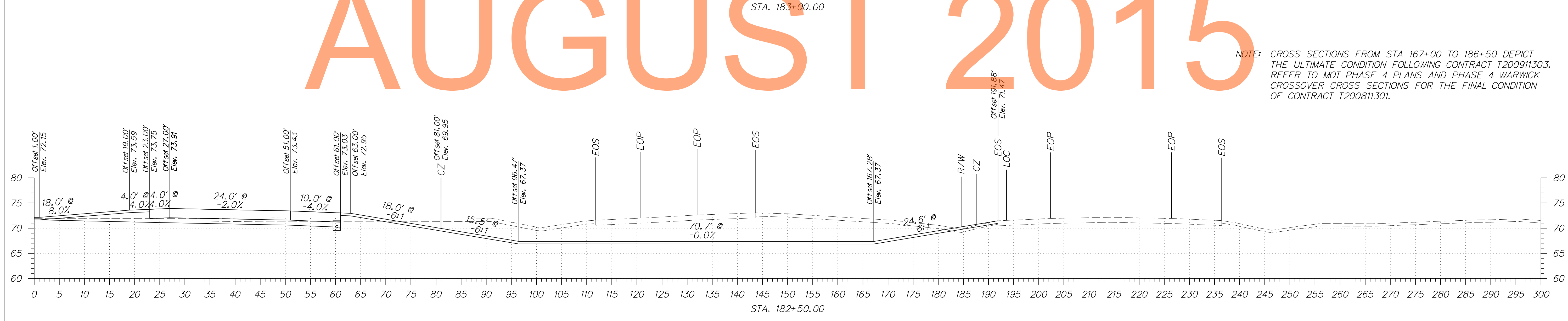
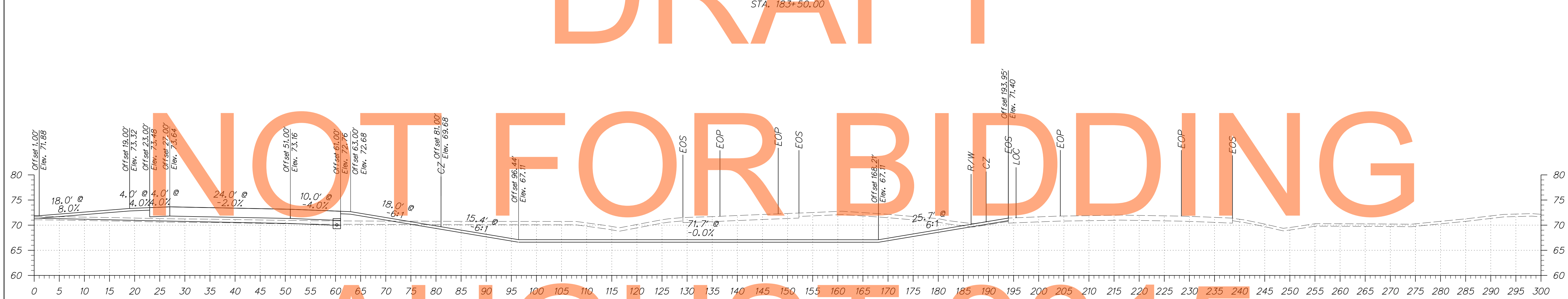
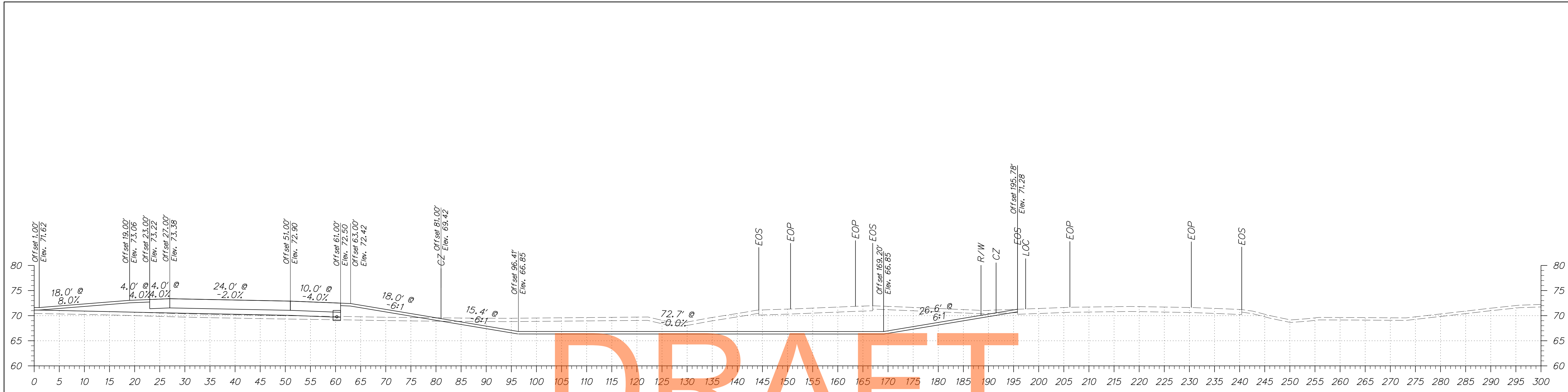

DRAFT

NOT FOR BIDDING

AUGUST 2015

NOTE: CROSS SECTIONS FROM STA 167+00 TO 186+50 DEPICT THE ULTIMATE CONDITION FOLLOWING CONTRACT T200911303. REFER TO MOT PHASE 4 PLANS AND PHASE 4 WARWICK CROSSOVER CROSS SECTIONS FOR THE FINAL CONDITION OF CONTRACT T200811301.

DRAFT

NOT FOR BIDDING

AUGUST 2015

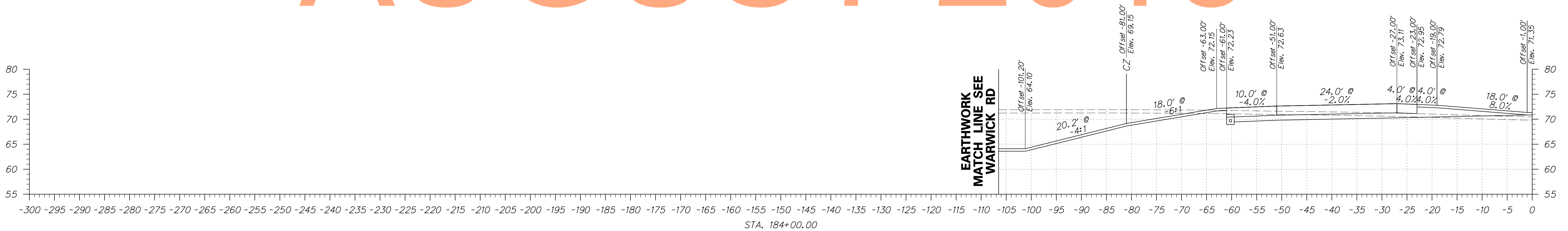
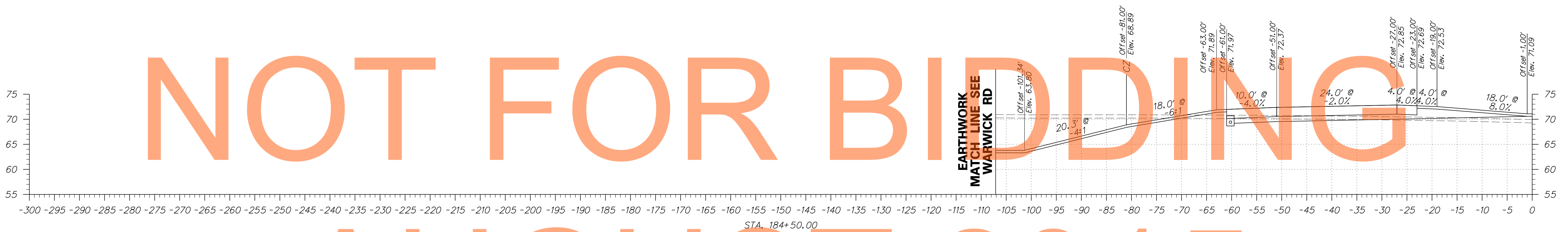
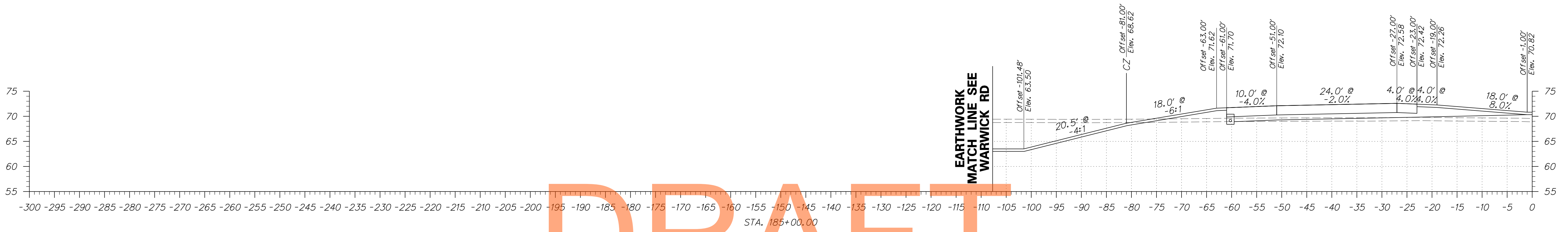

NOTE: CROSS SECTIONS FROM STA 167+00 TO 186+50 DEPICT THE ULTIMATE CONDITION FOLLOWING CONTRACT T200911303. REFER TO MOT PHASE 4 PLANS AND PHASE 4 WARWICK CROSSOVER CROSS SECTIONS FOR THE FINAL CONDITION OF CONTRACT T200811301.



ADDENDUMS / REVISIONS	

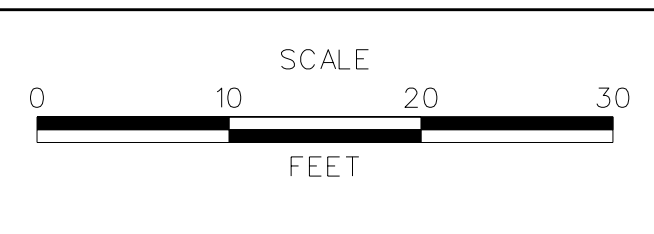

US 301  
MARYLAND STATE LINE  
TO LEVELS ROAD

CONTRACT T200811301	BRIDGE NO.
COUNTY NEW CASTLE	DESIGNED BY: JEG
	CHECKED BY: MFM

<b>CROSS SECTIONS US 301 MAINLINE</b>	SHEET NO. 74
	TOTAL SHTS. 539

# DRAFT

# NOT FOR BIDDING

# AUGUST 2015

NOTE: CROSS SECTIONS FROM STA 167+00 TO 186+50 DEPICT THE ULTIMATE CONDITION FOLLOWING CONTRACT T20091130.3. REFER TO MOT PHASE 4 PLANS AND PHASE 4 WARWICK CROSSOVER CROSS SECTIONS FOR THE FINAL CONDITION OF CONTRACT T200811301.

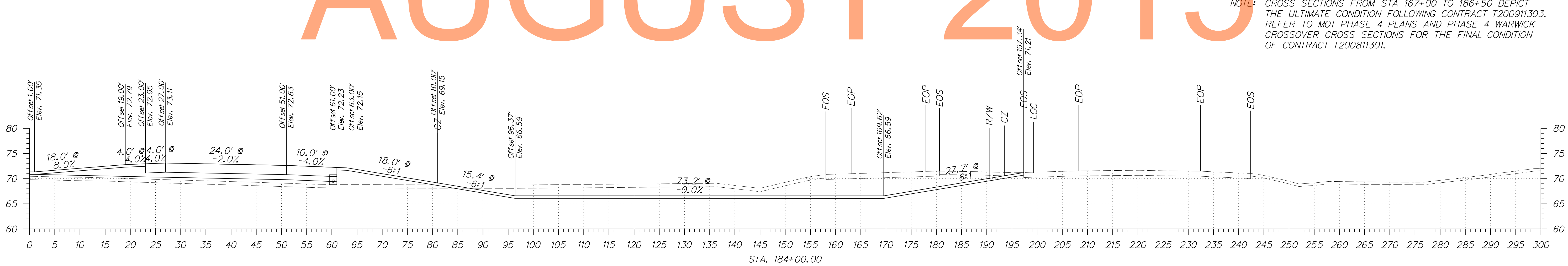
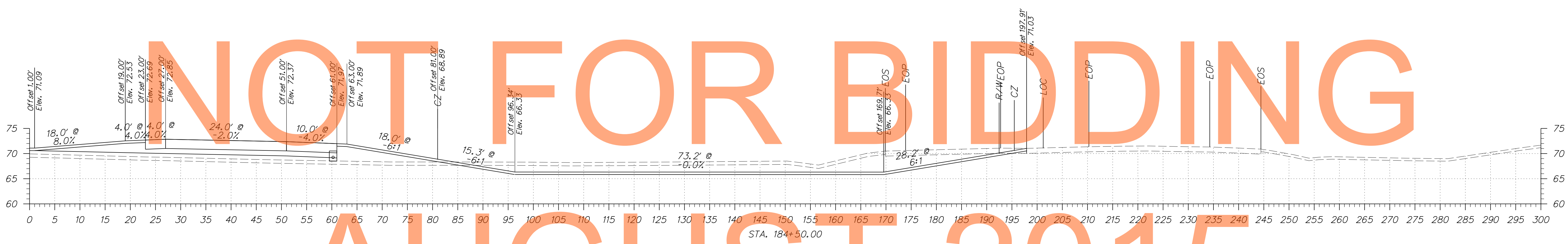
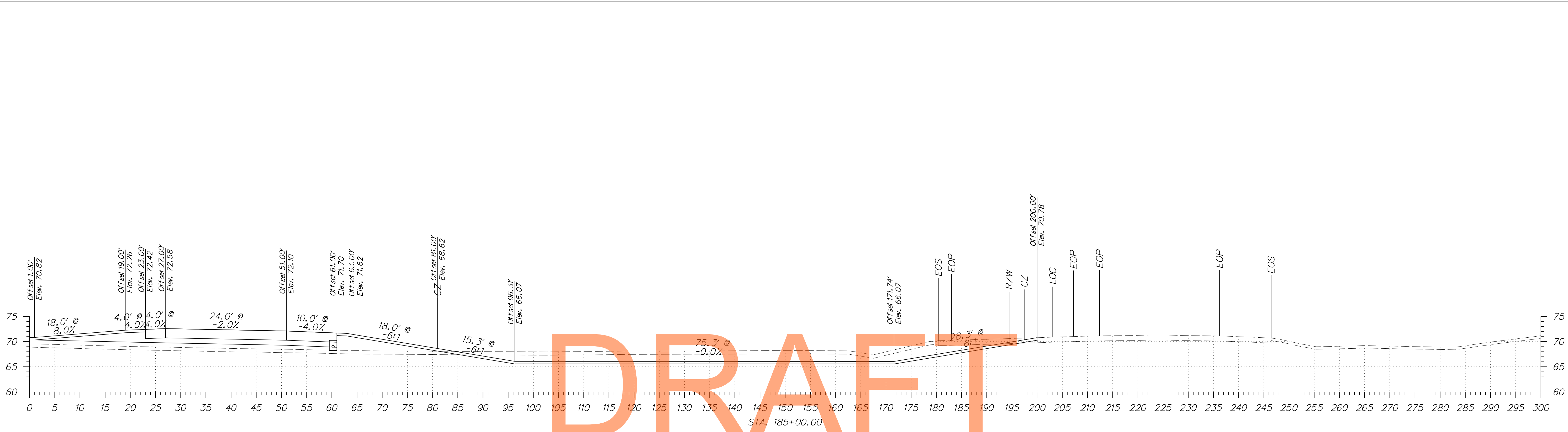

# DRAFT

# NOT FOR BIDDING

# AUGUST 2015

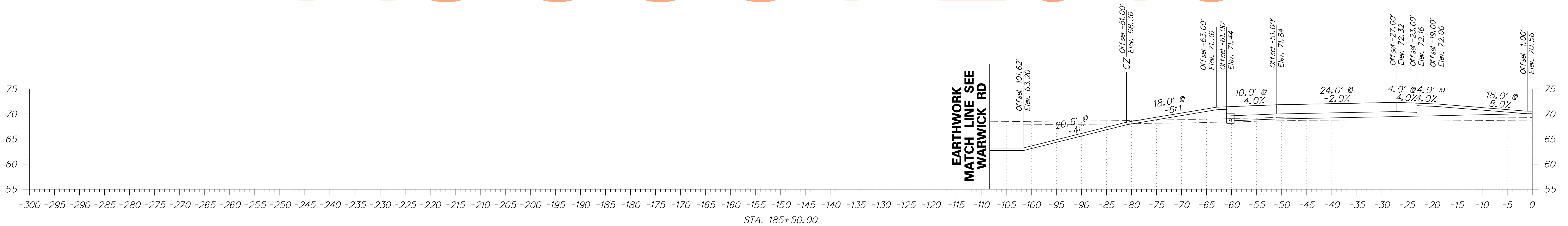
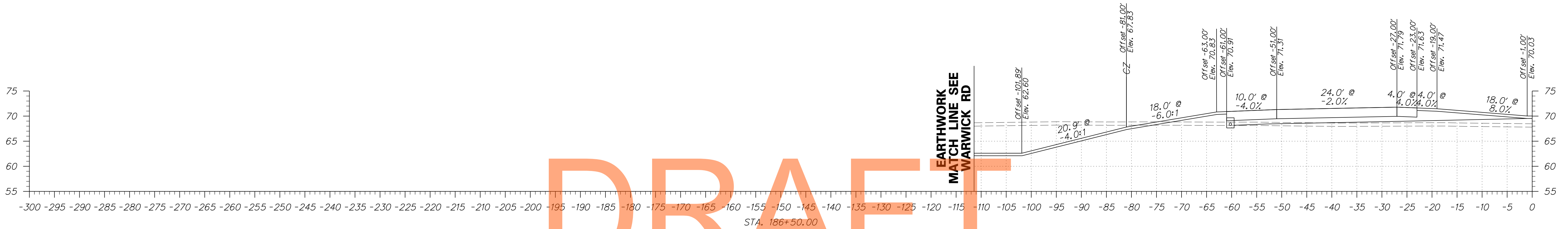

NOTE: CROSS SECTIONS FROM STA 167+00 TO 186+50 DEPICT THE ULTIMATE CONDITION FOLLOWING CONTRACT T200911303. REFER TO MOT PHASE 4 PLANS AND PHASE 4 WARWICK CROSSOVER CROSS SECTIONS FOR THE FINAL CONDITION OF CONTRACT T200811301.

EARTHWORK  
MATCH LINE (AHEAD)  
SEE SWM PLANS  
BMP NO. 611

DRAFT

NOT FOR BIDDING

AUGUST 2015

NOTE: CROSS SECTIONS FROM STA 167+00 TO 186+50 DEPICT THE ULTIMATE CONDITION FOLLOWING CONTRACT T200911303. REFER TO MOT PHASE 4 PLANS AND PHASE 4 WARWICK CROSSOVER CROSS SECTIONS FOR THE FINAL CONDITION OF CONTRACT T200811301.

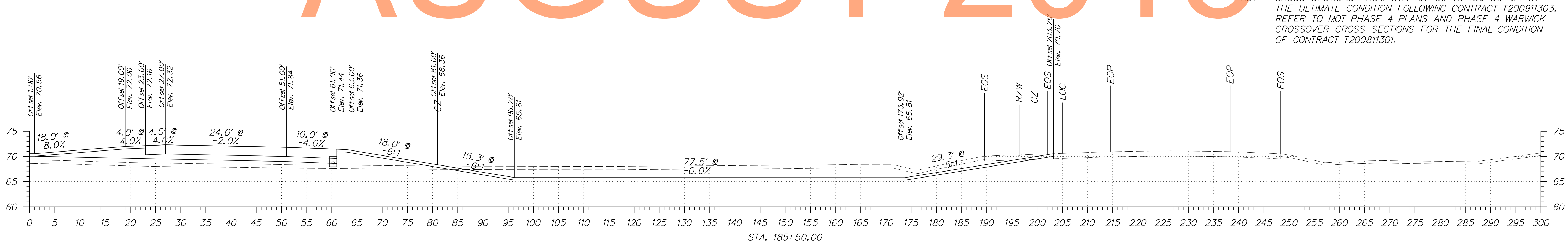
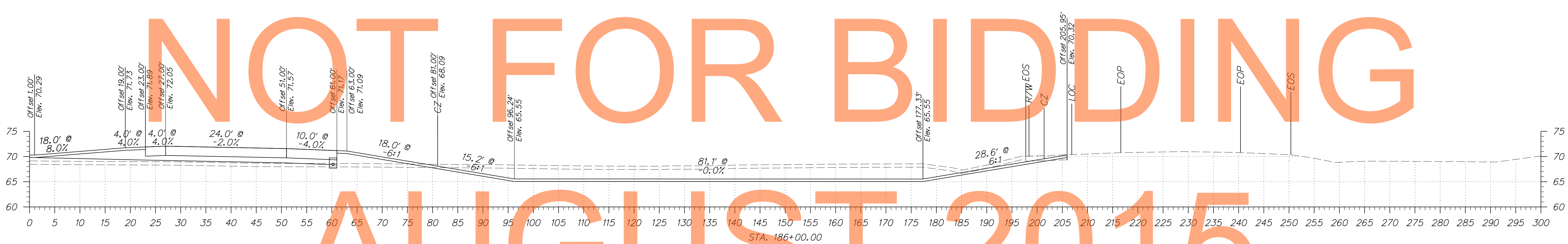

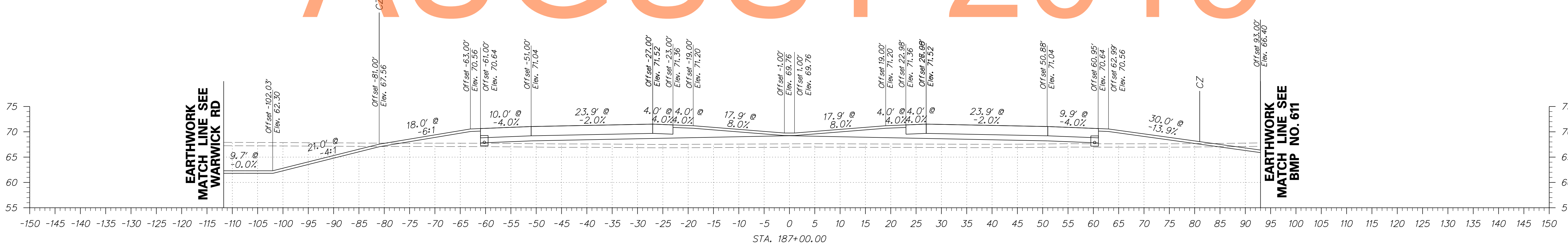
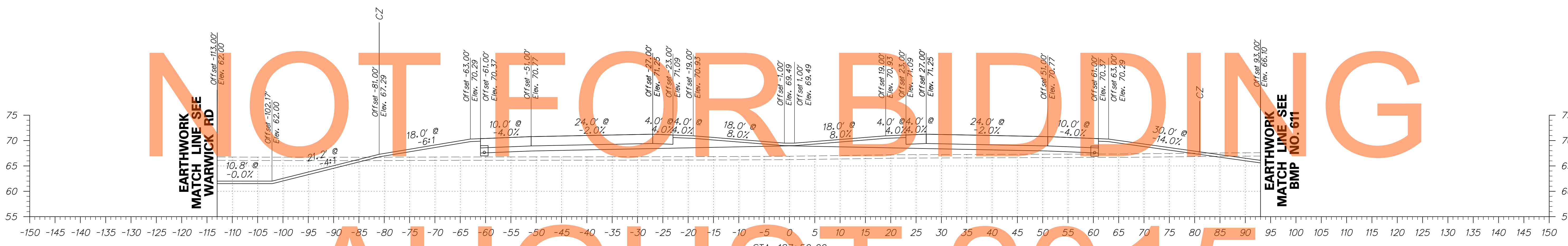
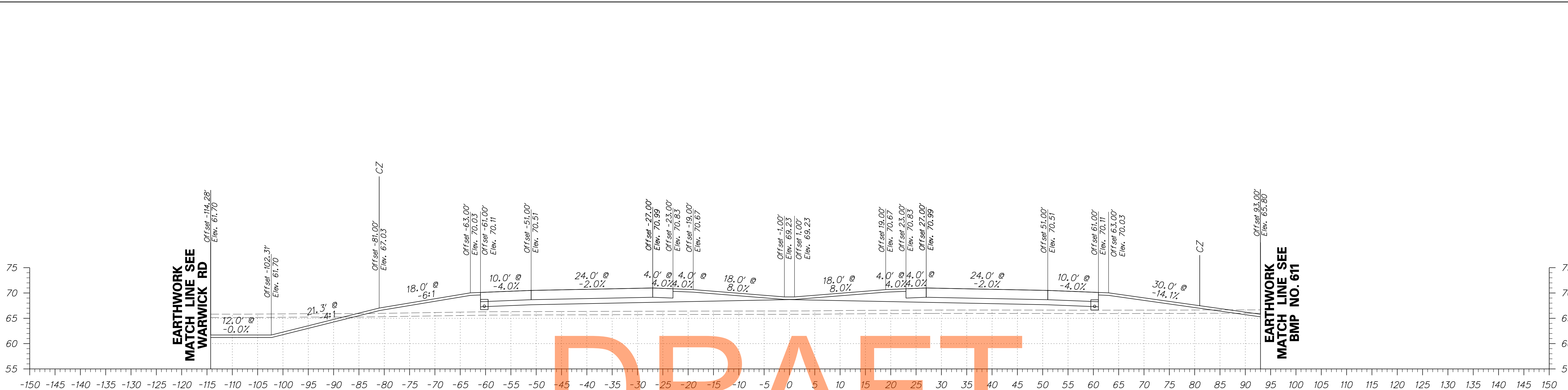

**DRAFT**

**NOT FOR BIDDING**

**AUGUST 2015**

ADDENDUMS / REVISIONS	

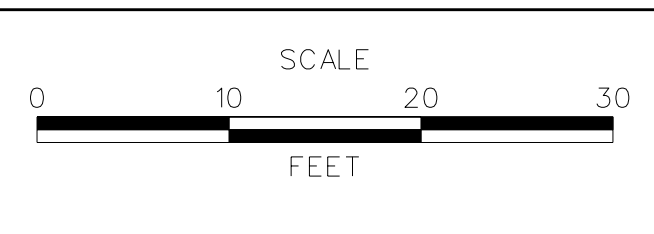

**US 301 MARYLAND STATE LINE TO LEVELS ROAD**

CONTRACT T200811301	BRIDGE NO.
COUNTY NEW CASTLE	DESIGNED BY: SL
	CHECKED BY: RK

<b>CROSS SECTIONS US 301 MAINLINE</b>	SHEET NO. 78
	TOTAL SHTS. 539

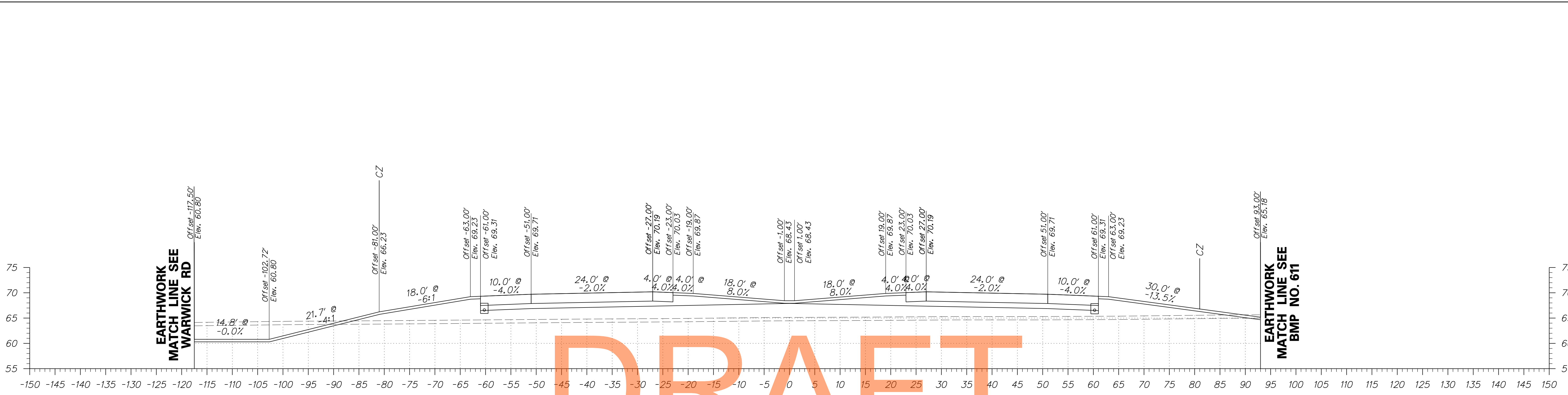

DRAFT

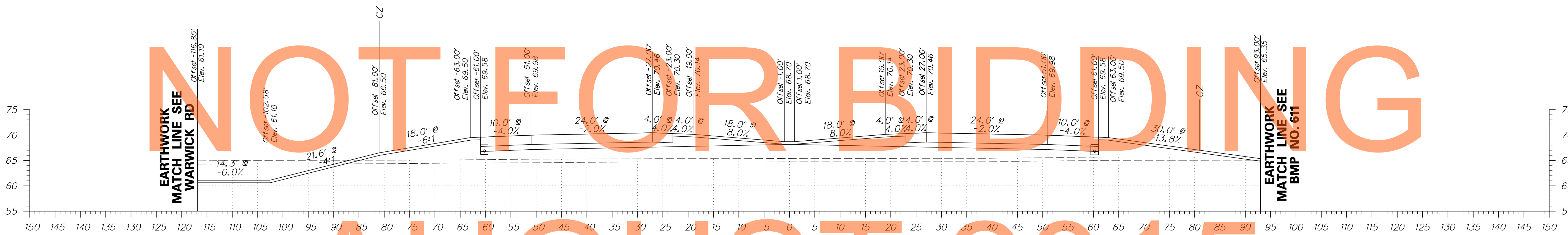

AUGUST 2015

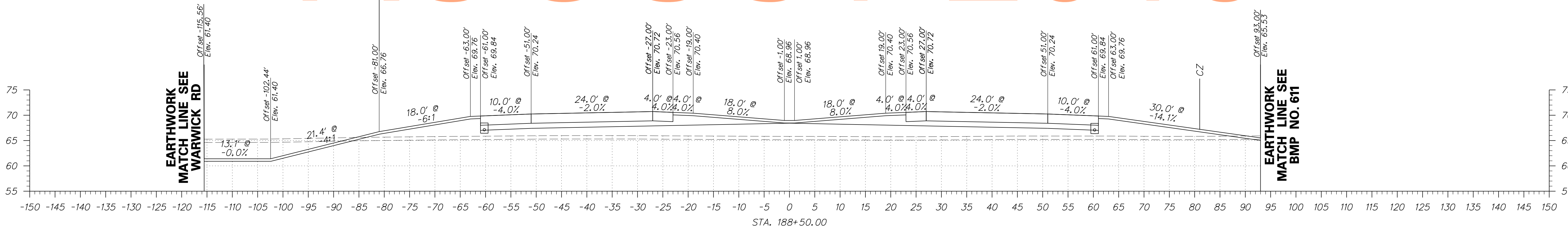

ADDENDUMS / REVISIONS	

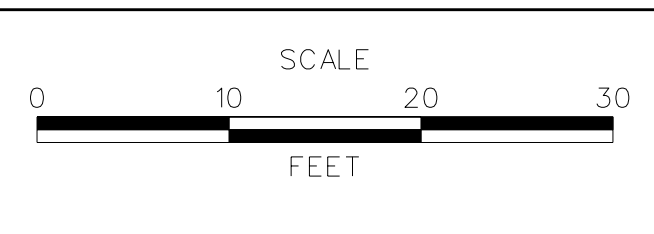

CONTRACT T200811301	BRIDGE NO.
COUNTY NEW CASTLE	DESIGNED BY: SL
	CHECKED BY: RK

<b>CROSS SECTIONS</b> <b>US 301 MAINLINE</b>	SHEET NO. 79
	TOTAL SHTS. 539

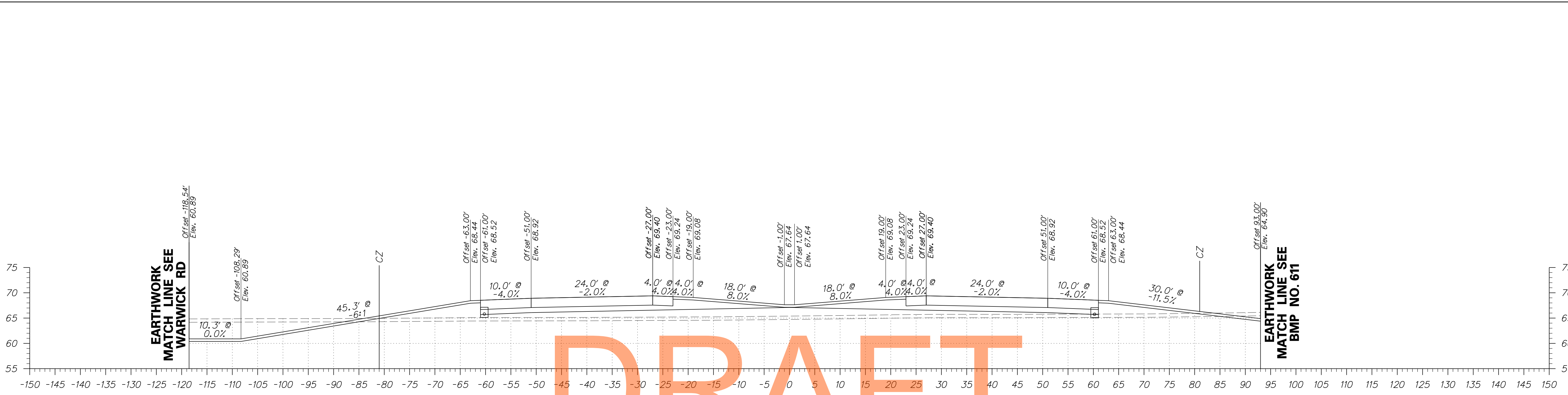

DRAFT



AUGUST 2015

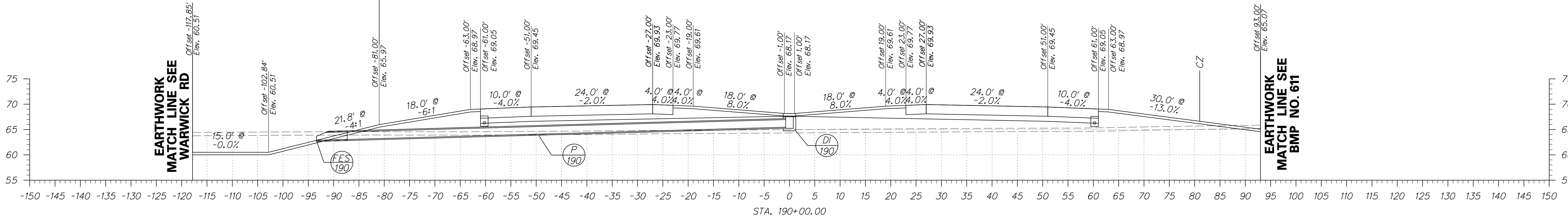

ADDENDUMS / REVISIONS	

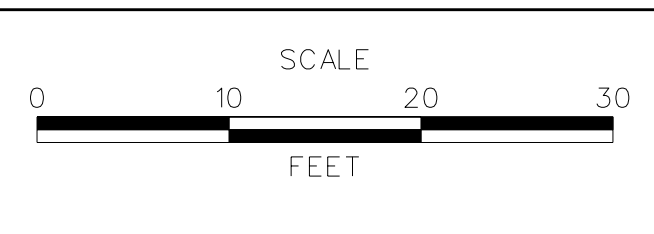

**US 301**  
**MARYLAND STATE LINE**  
**TO LEVELS ROAD**

CONTRACT T200811301	BRIDGE NO.
COUNTY NEW CASTLE	DESIGNED BY: SL
	CHECKED BY: RK

<b>CROSS SECTIONS</b> <b>US 301 MAINLINE</b>	SHEET NO. 80
	TOTAL SHTS. 539



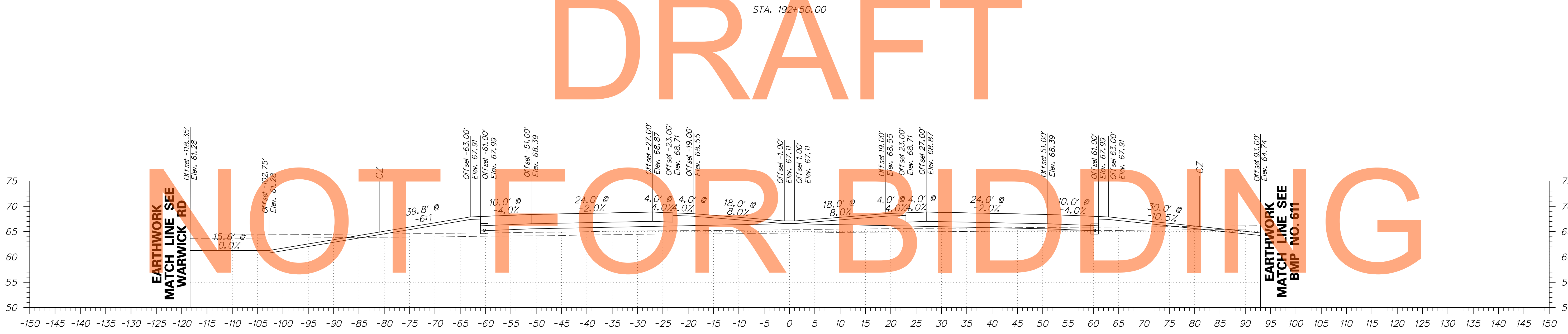
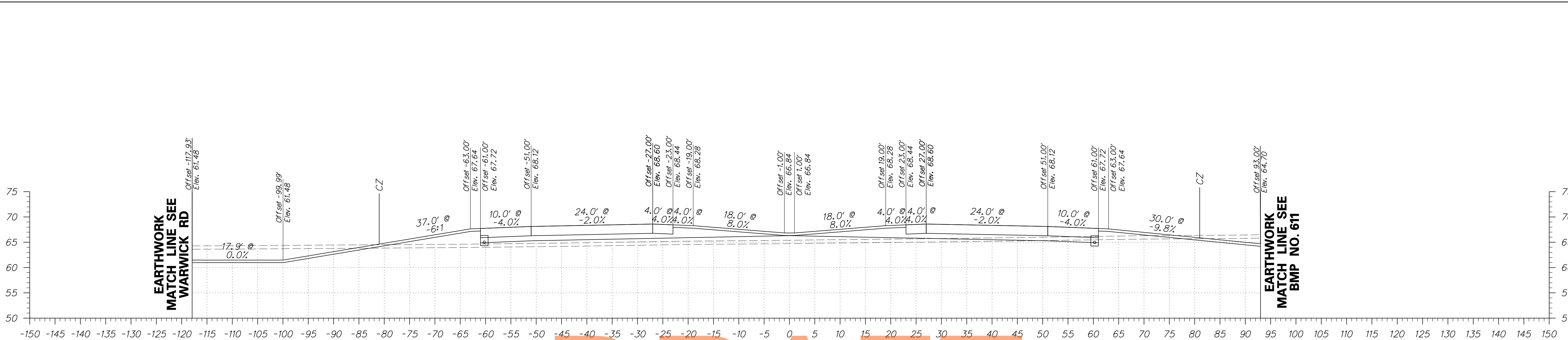

DRAFT

NOT FOR BIDDING

AUGUST 2015

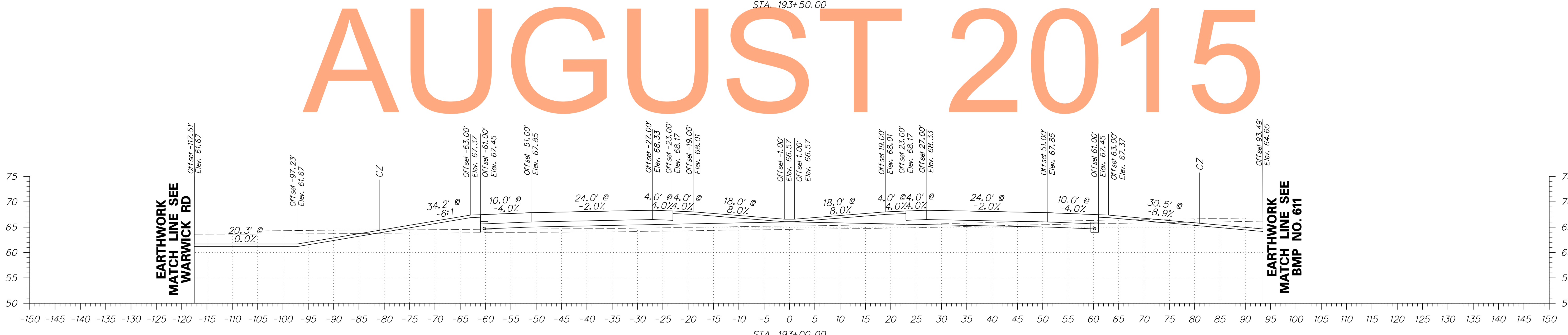
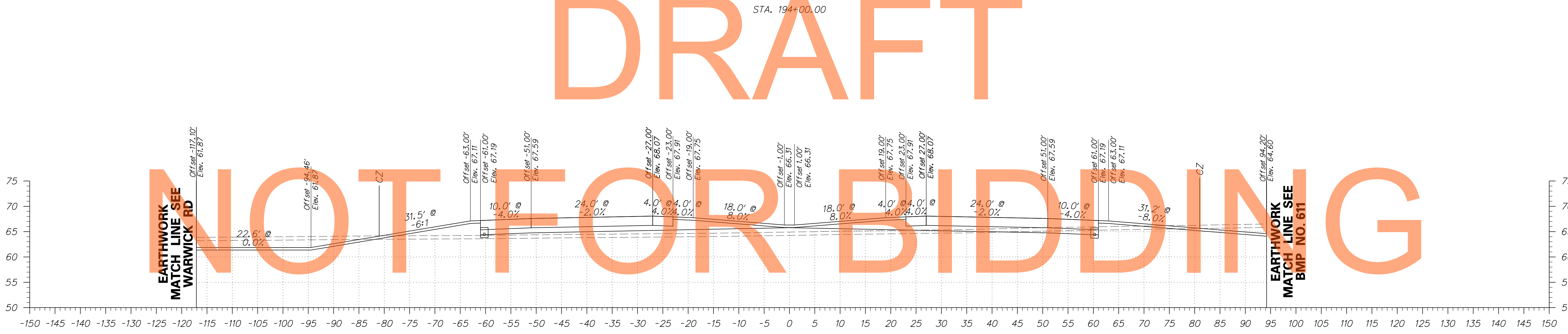
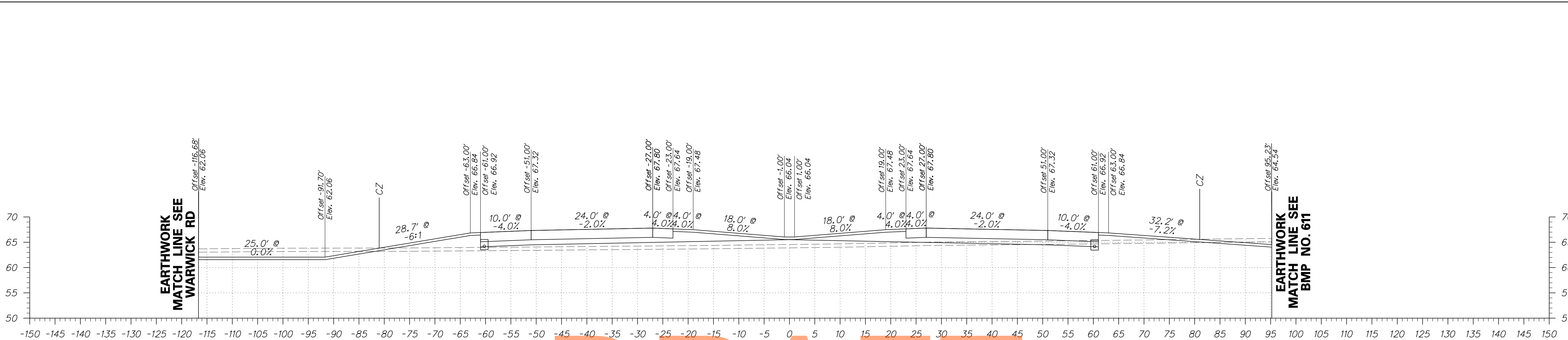

DRAFT

NOT FOR BIDDING

AUGUST 2015

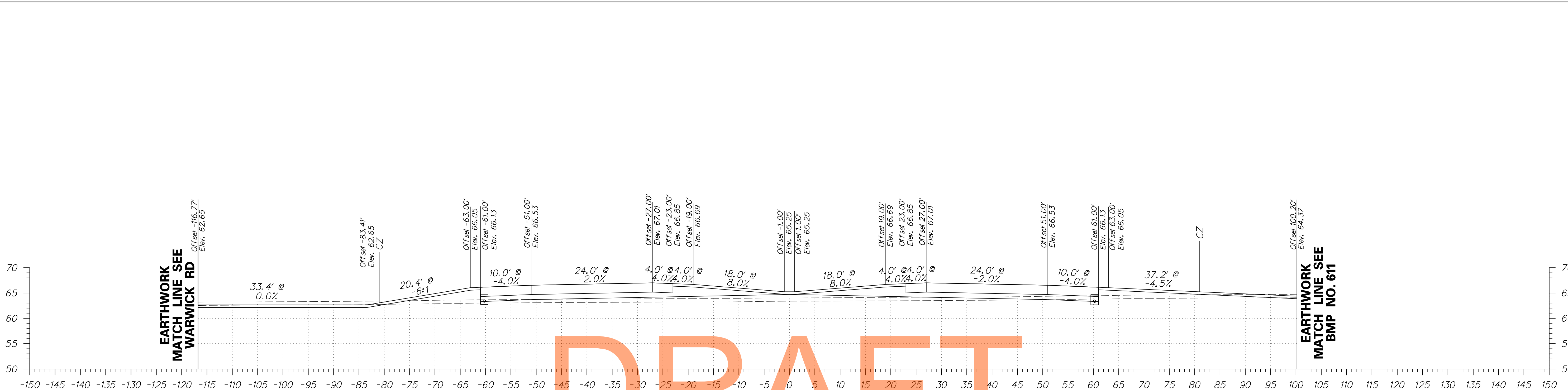

DRAFT

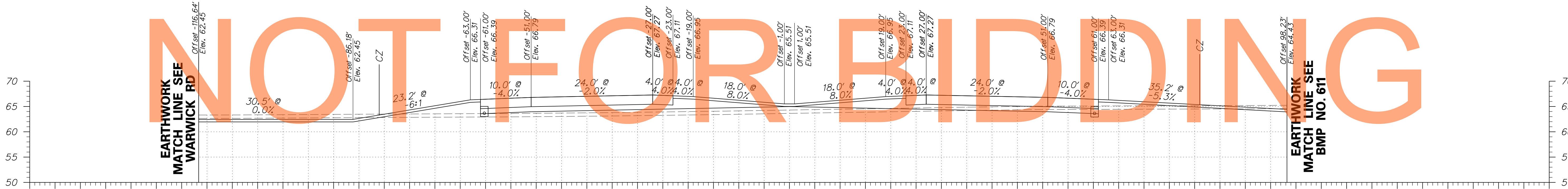

NOT FOR BIDDING

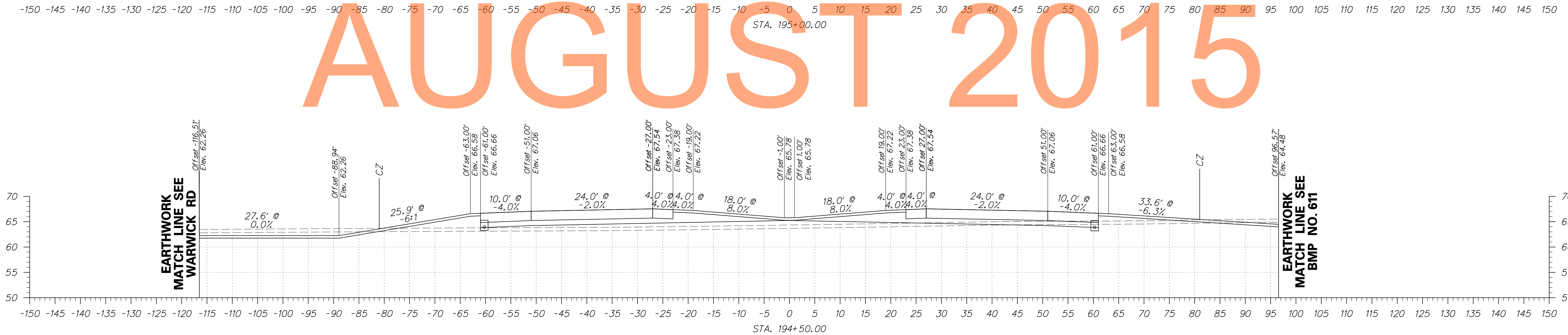

AUGUST 2015

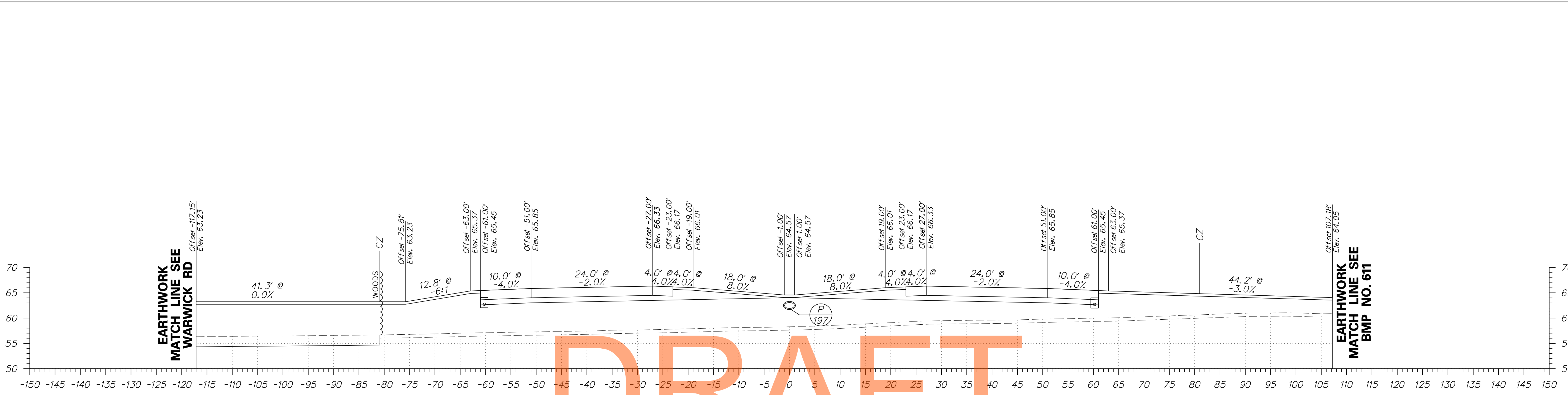

DRAFT

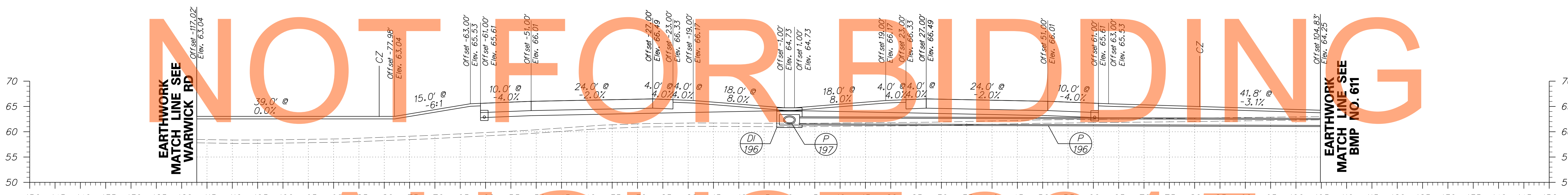

AUGUST 2015

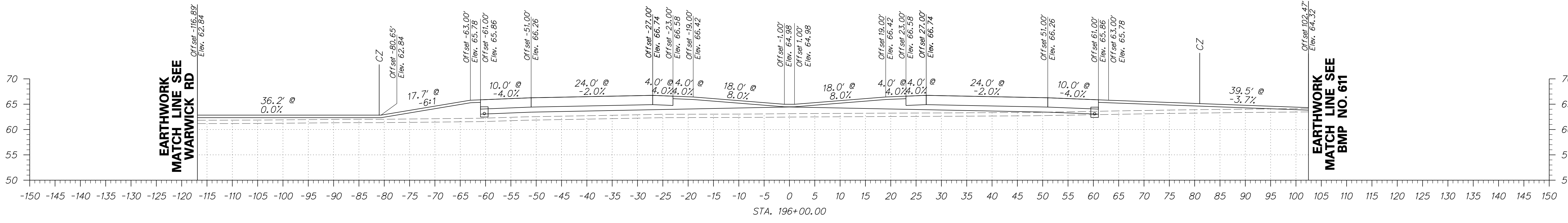

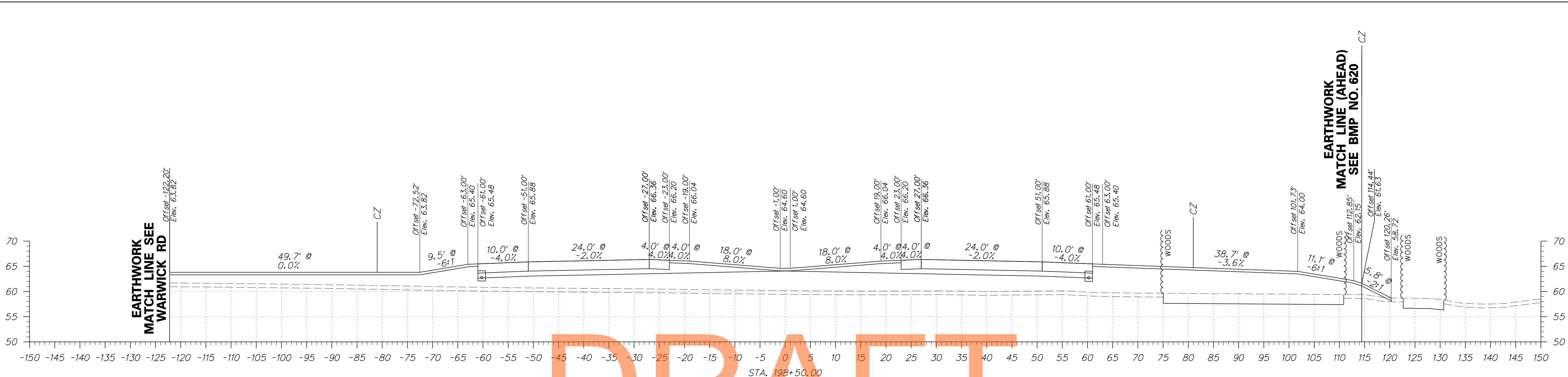

DRAFT

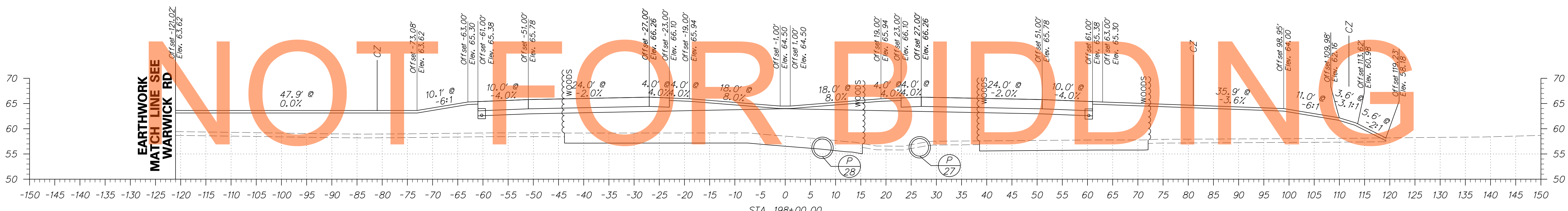

AUGUST 2015

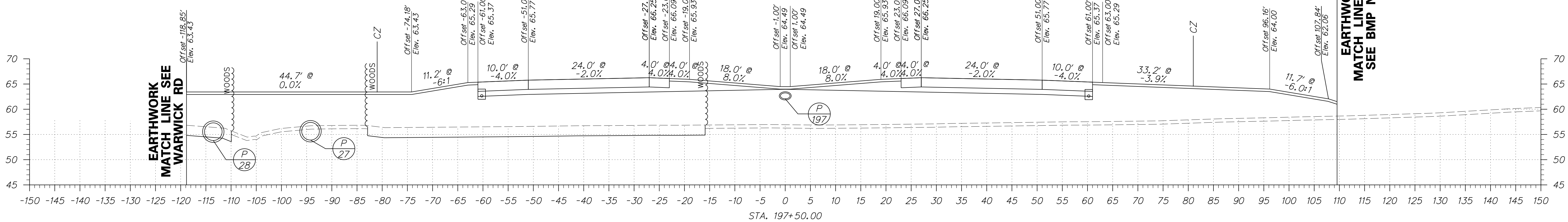

ADDENDUMS / REVISIONS	

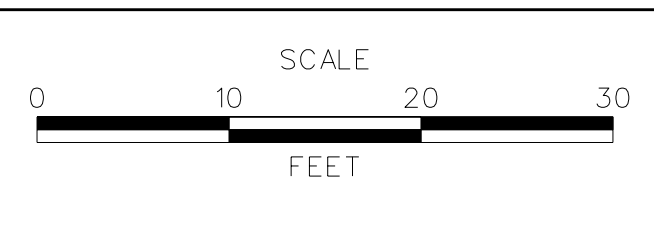

CONTRACT T200811301	BRIDGE NO.
COUNTY NEW CASTLE	DESIGNED BY: SL
	CHECKED BY: RK

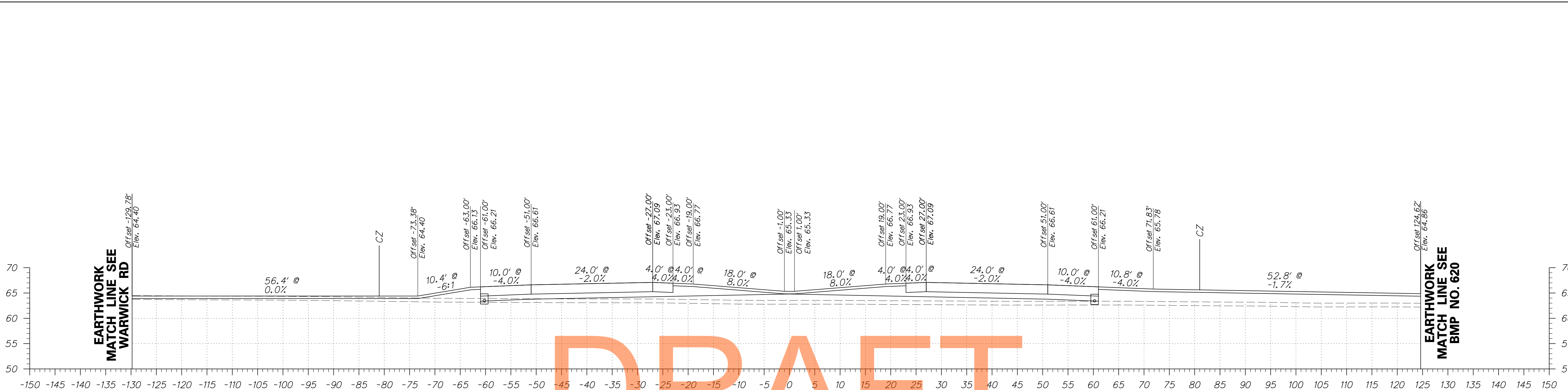

DRAFT

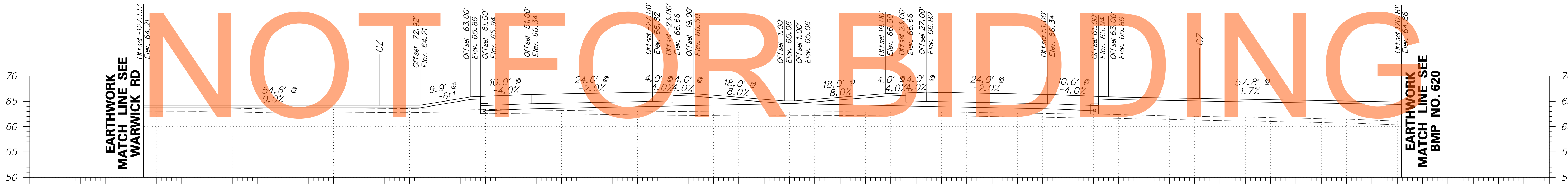

AUGUST 2015

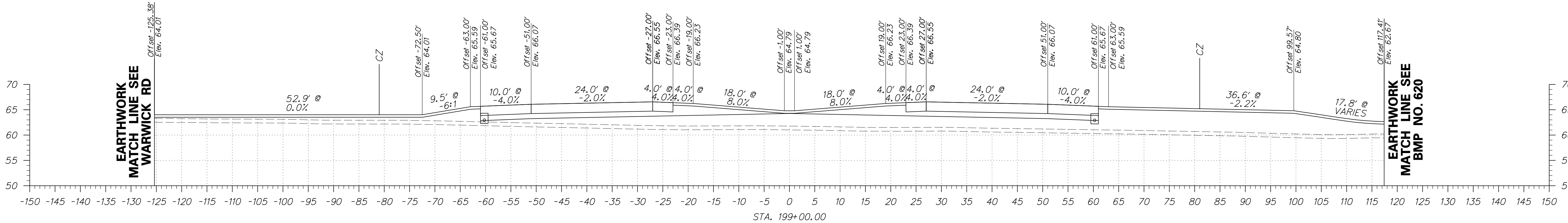

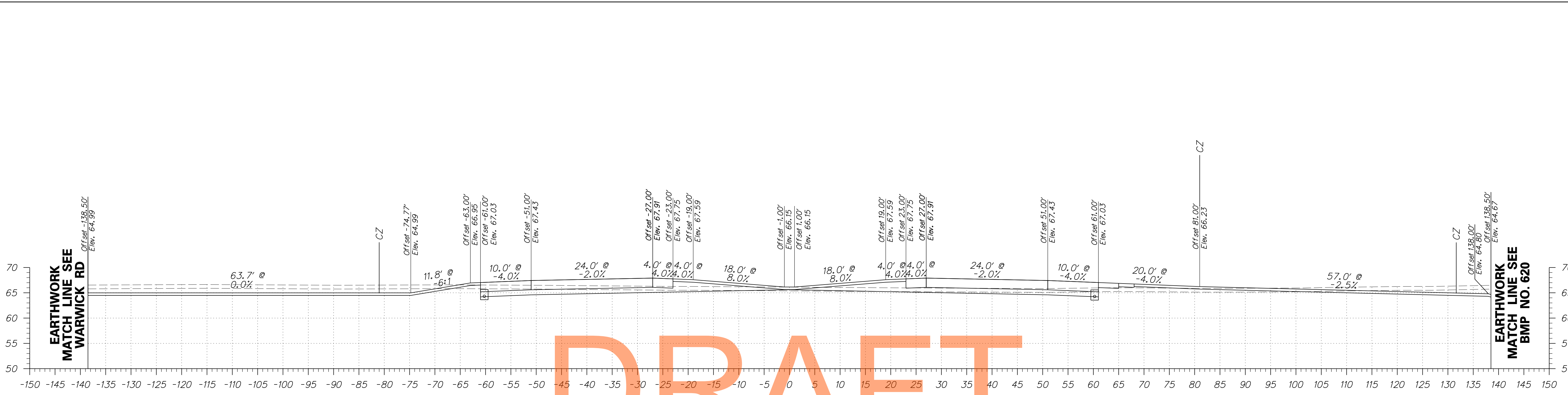

DRAFT

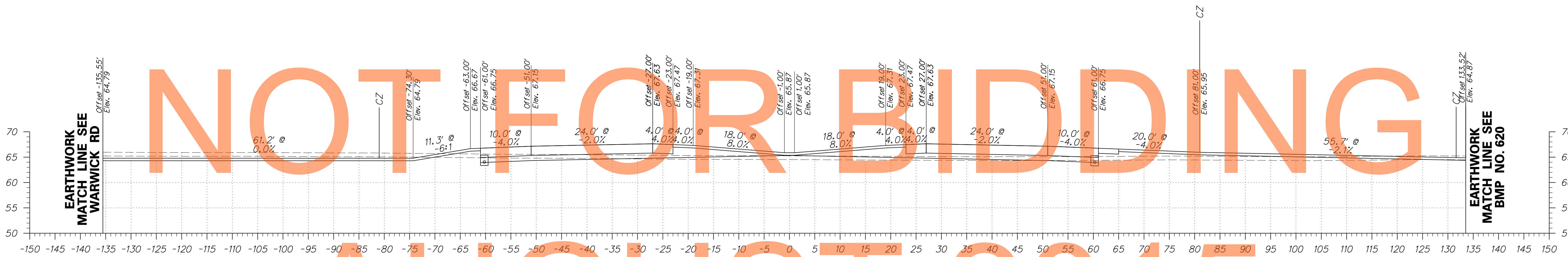

AUGUST 2015

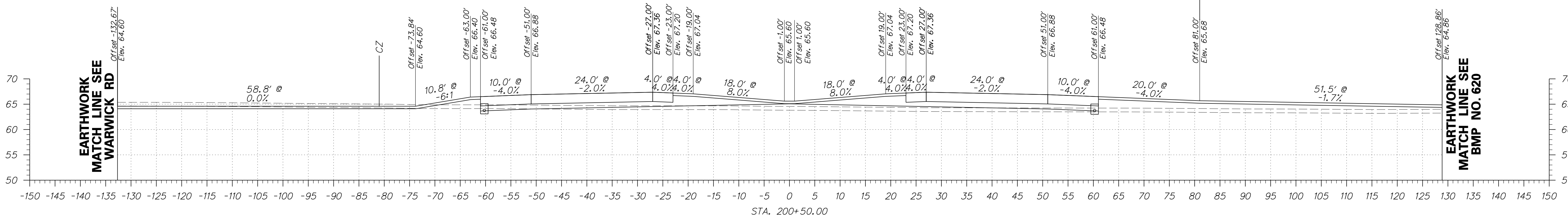

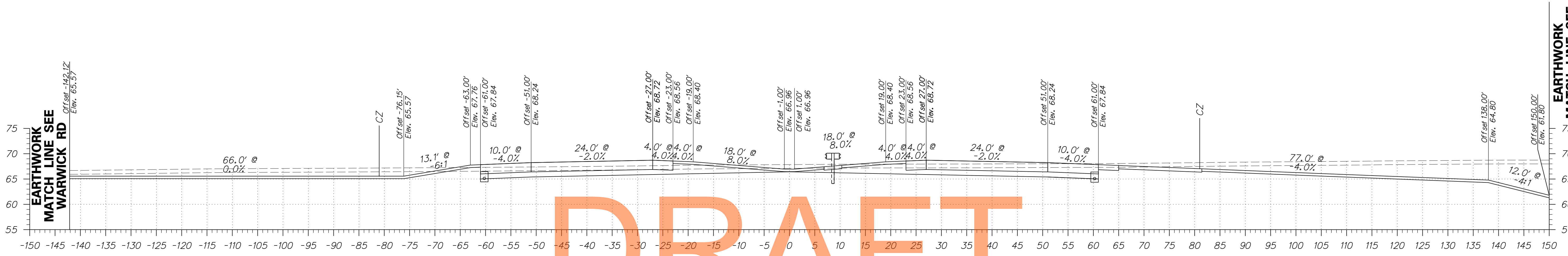

DRAFT

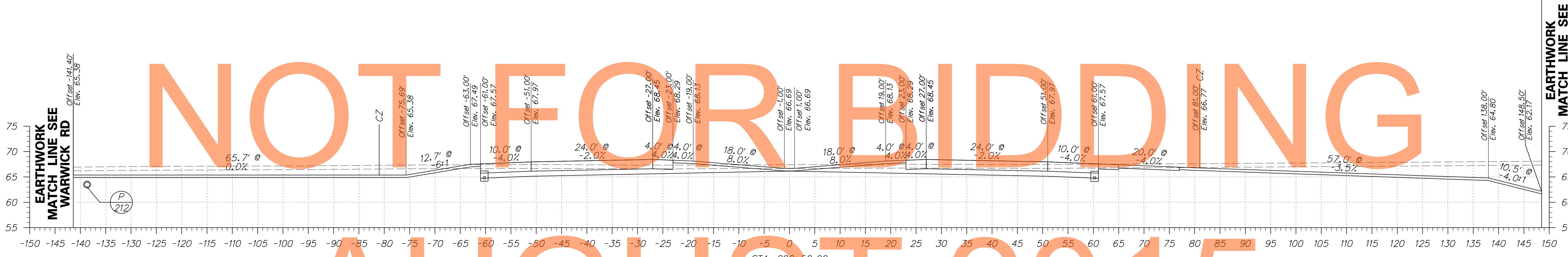

NOT FOR BIDDING

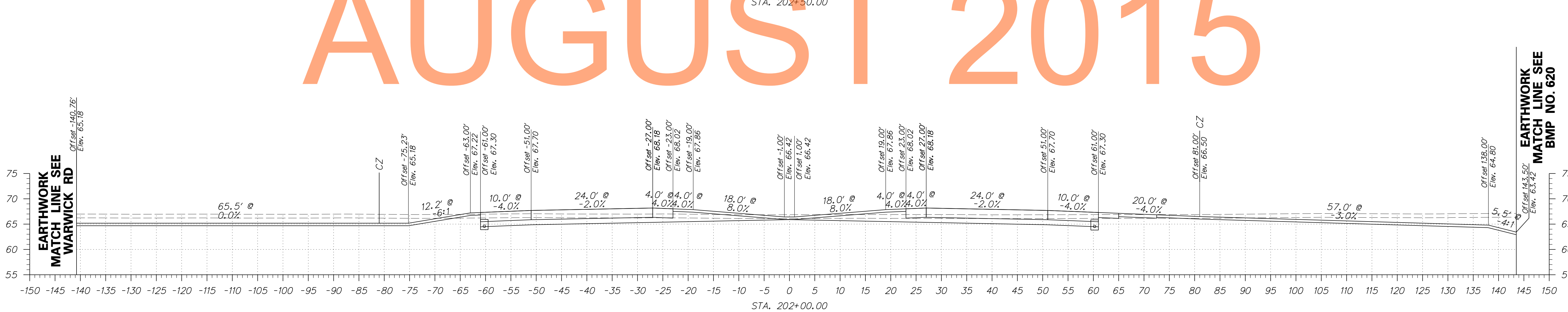

AUGUST 2015



EARTHWORK  
MATCH LINE SEE  
WARWICK RD

STA. 204+50.00

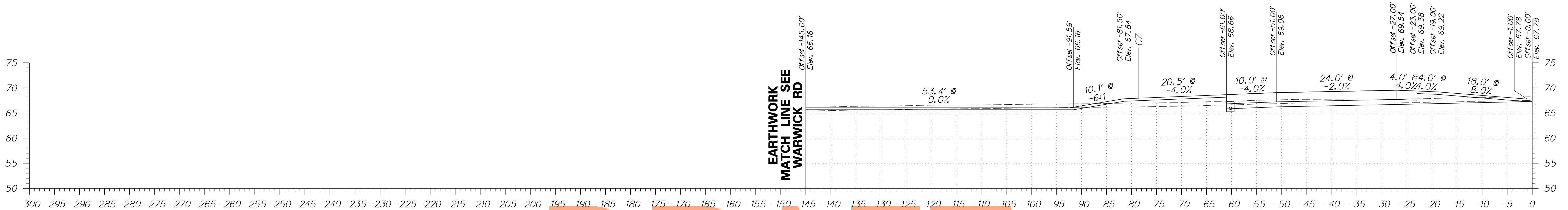

DRAFT

EARTHWORK  
MATCH LINE SEE  
WARWICK RD

STA. 204+00.00

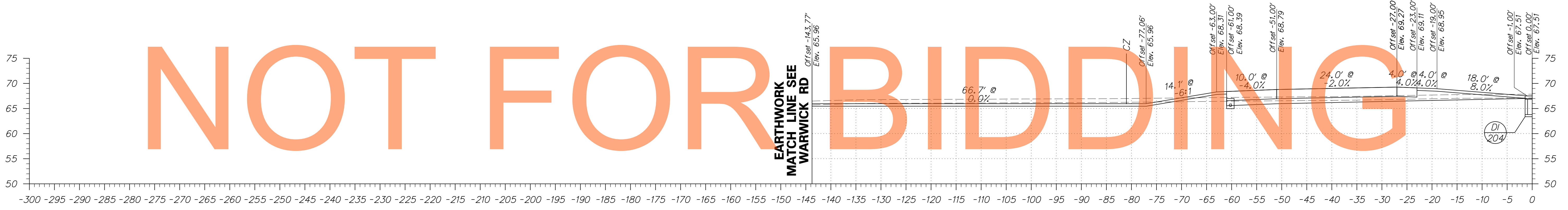

AUGUST 2015

EARTHWORK  
MATCH LINE SEE  
WARWICK RD

STA. 203+50.00

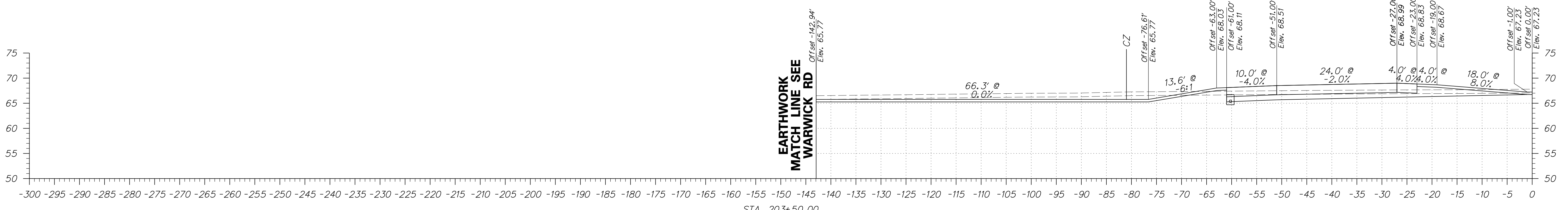

ADDENDUMS / REVISIONS	

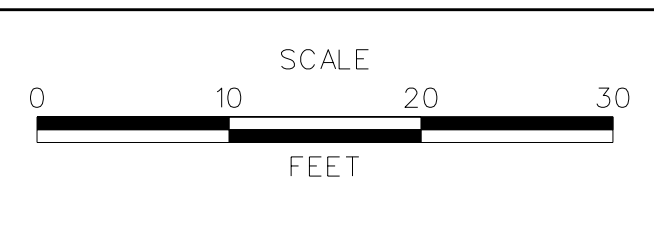

US 301  
MARYLAND STATE LINE  
TO LEVELS ROAD

CONTRACT T200811301	BRIDGE NO.
COUNTY NEW CASTLE	DESIGNED BY: SL
	CHECKED BY: RK

CROSS SECTIONS US 301 MAINLINE	SHEET NO. 89
	TOTAL SHTS. 539

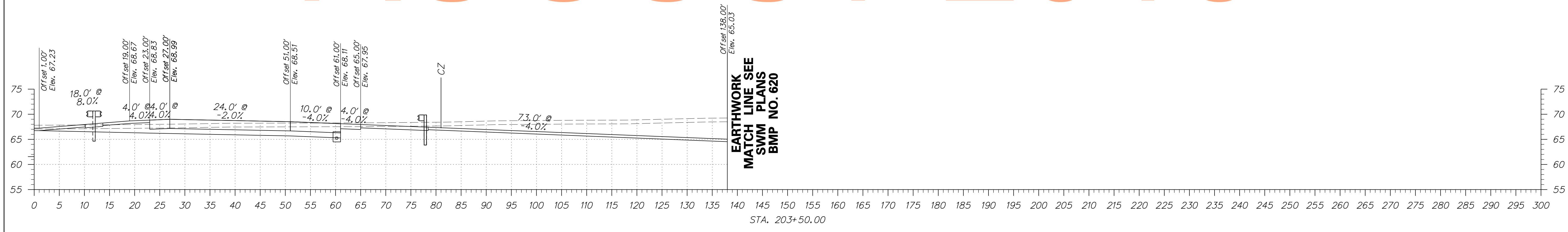
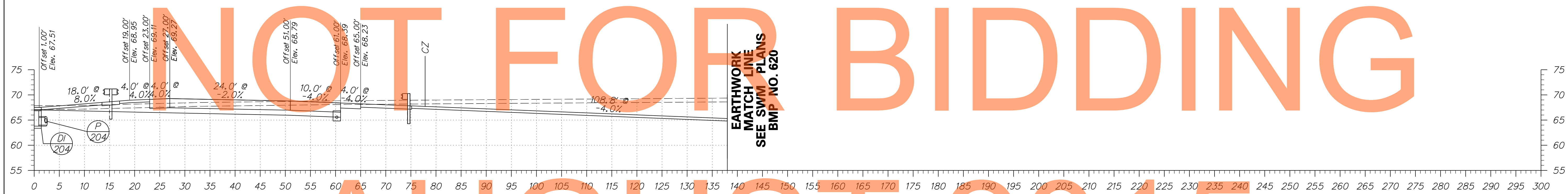
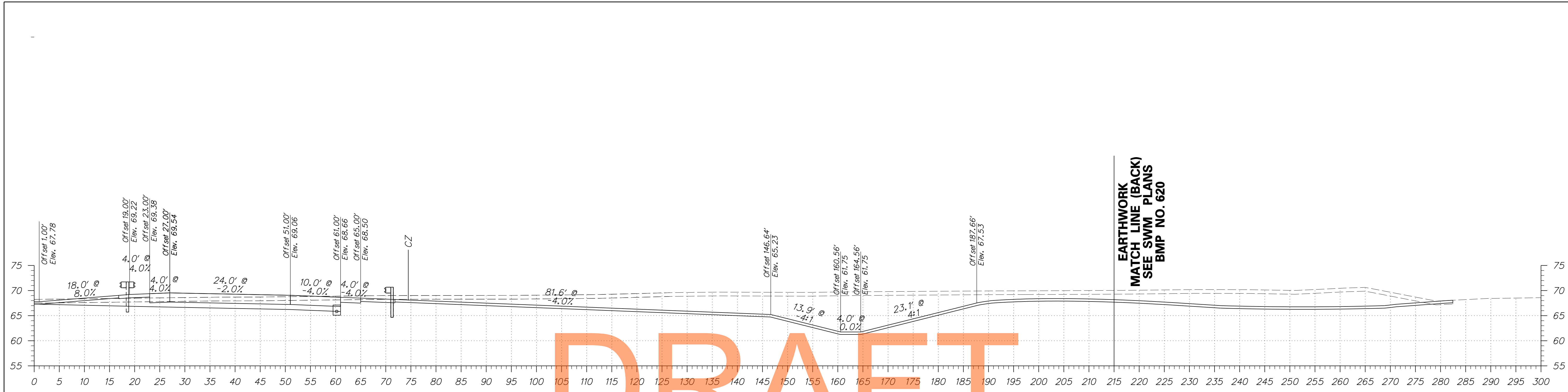

DRAFT

NOT FOR BIDDING

AUGUST 2015

# DRAFT

# NOT FOR BIDDING

# AUGUST 2015

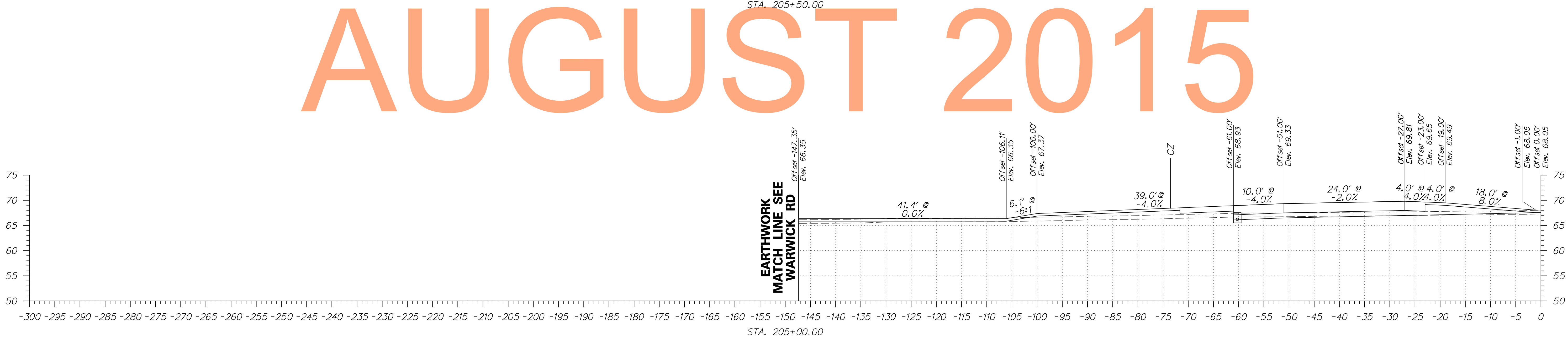
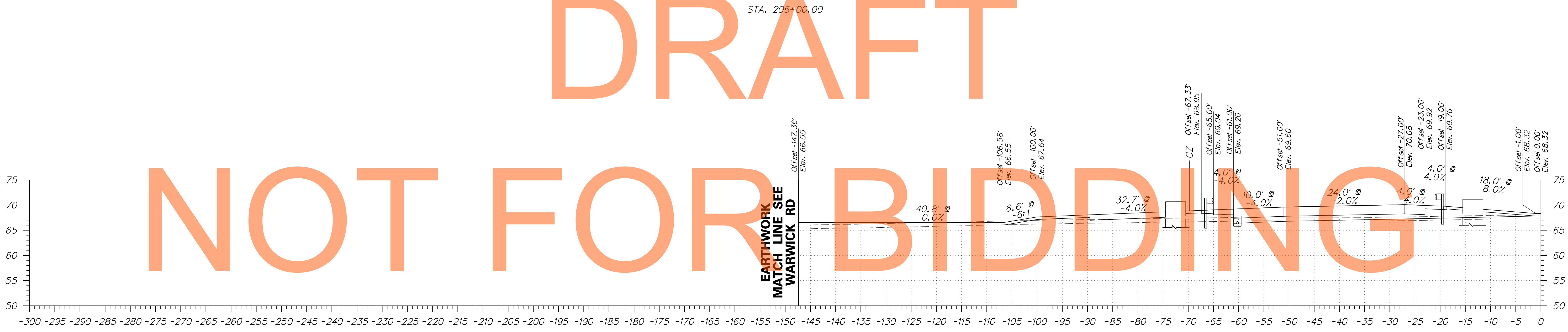
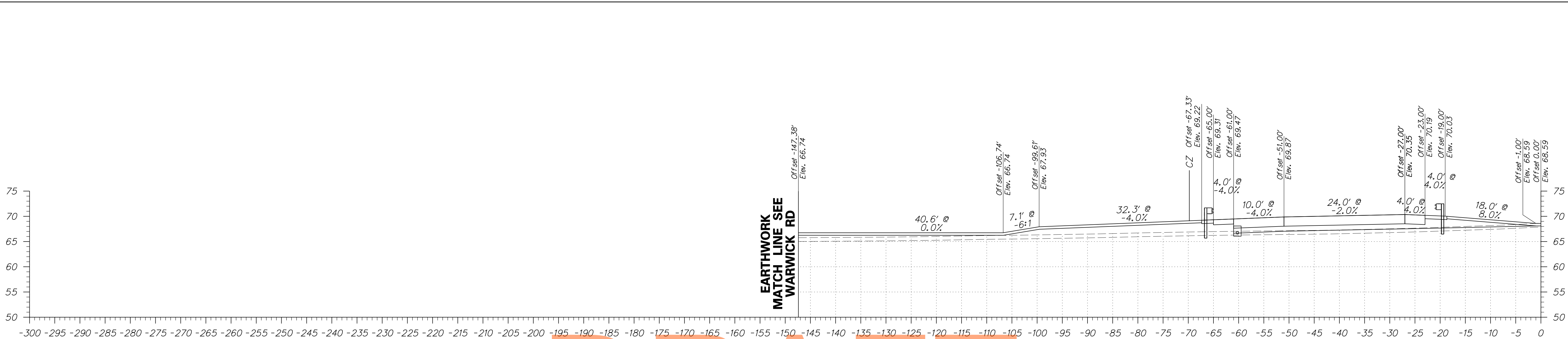

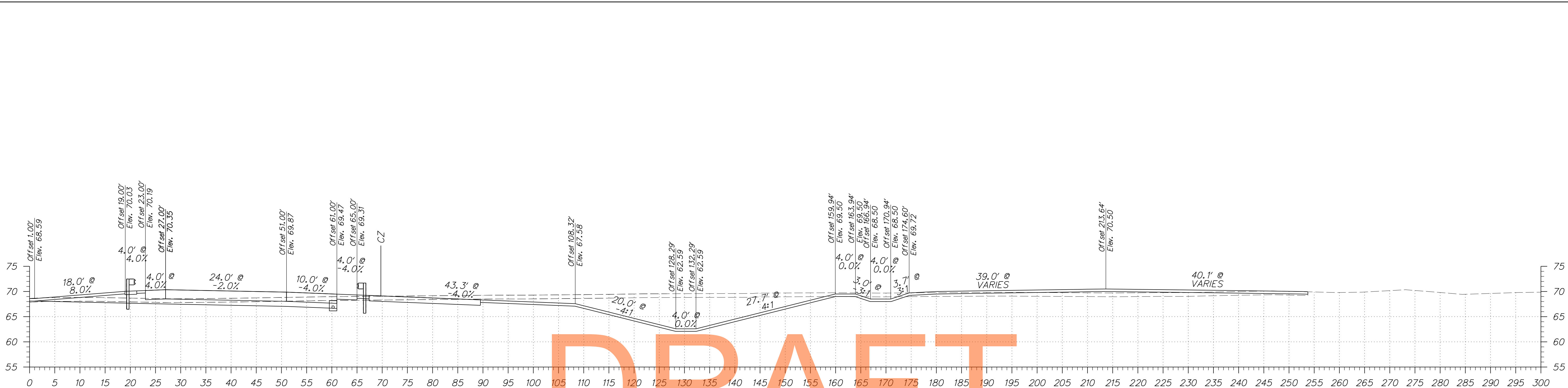

DRAFT

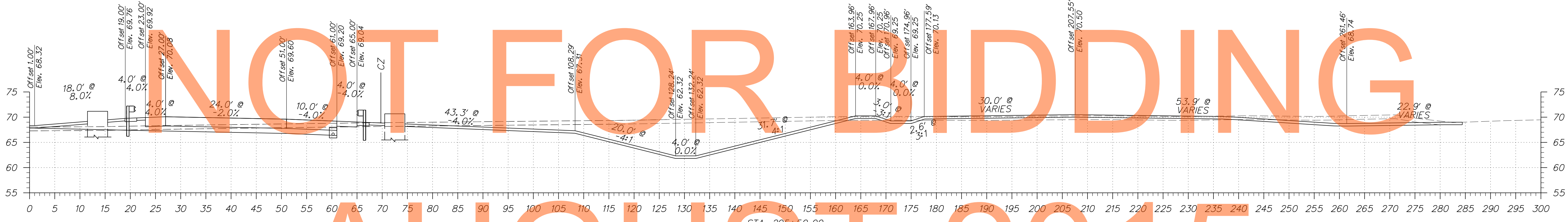

AUGUST 2015

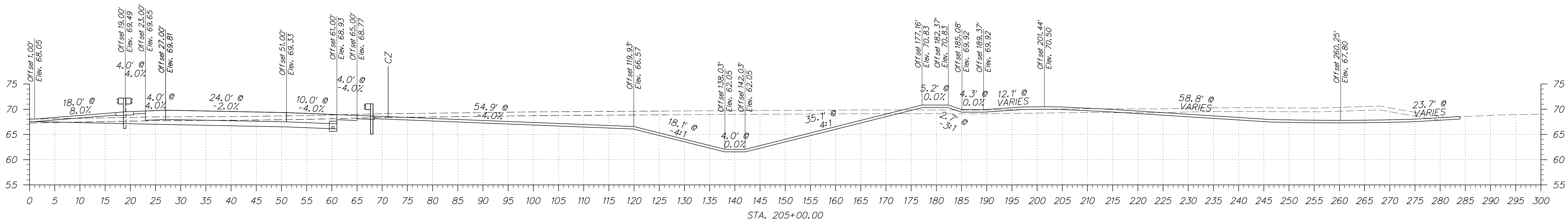

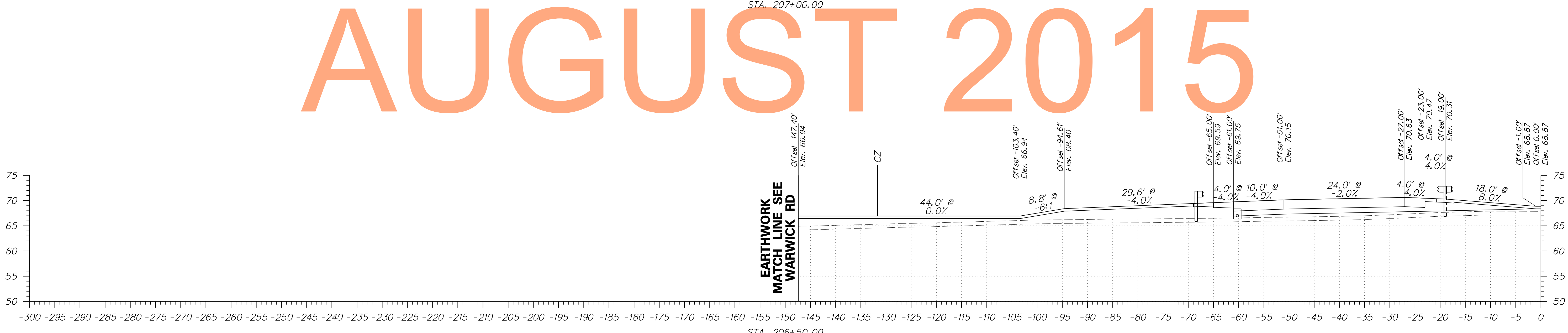
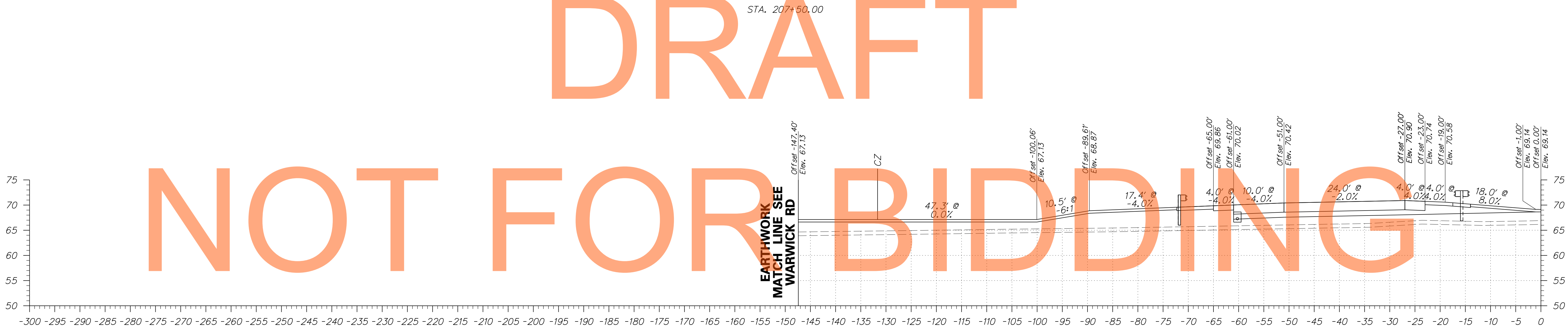
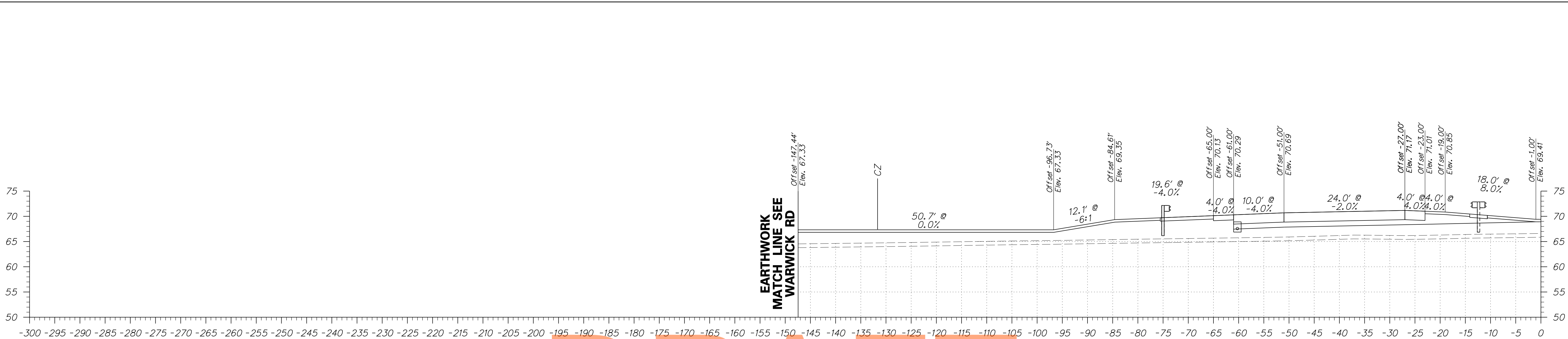

DRAFT  
NOT FOR BIDDING  
AUGUST 2015

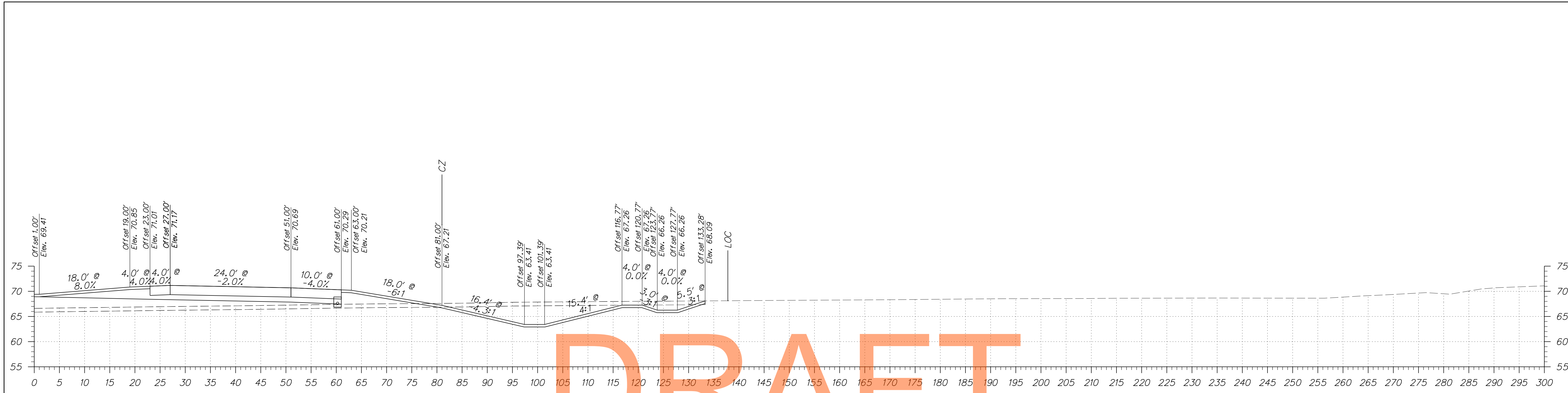

DRAFT

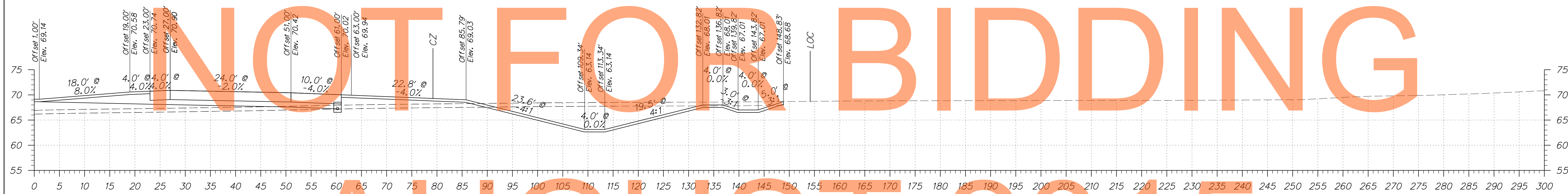

NOT FOR BIDDING

AUGUST 2015

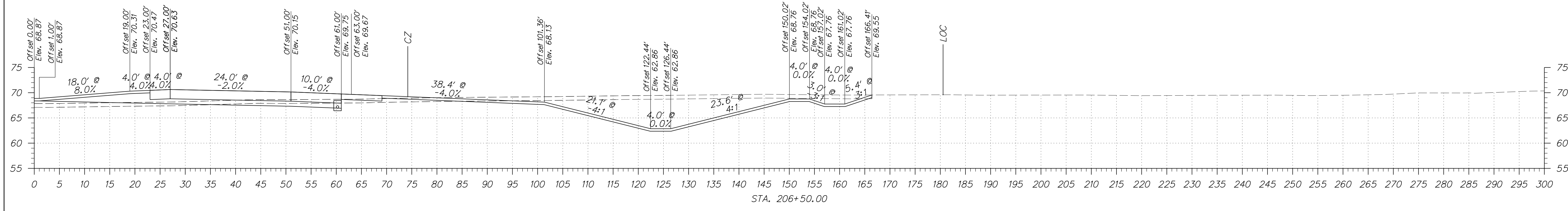

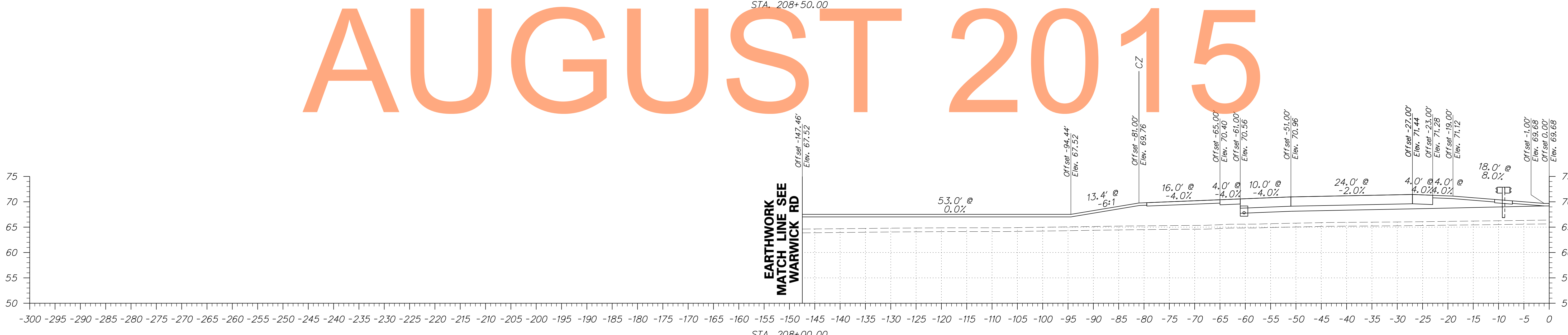
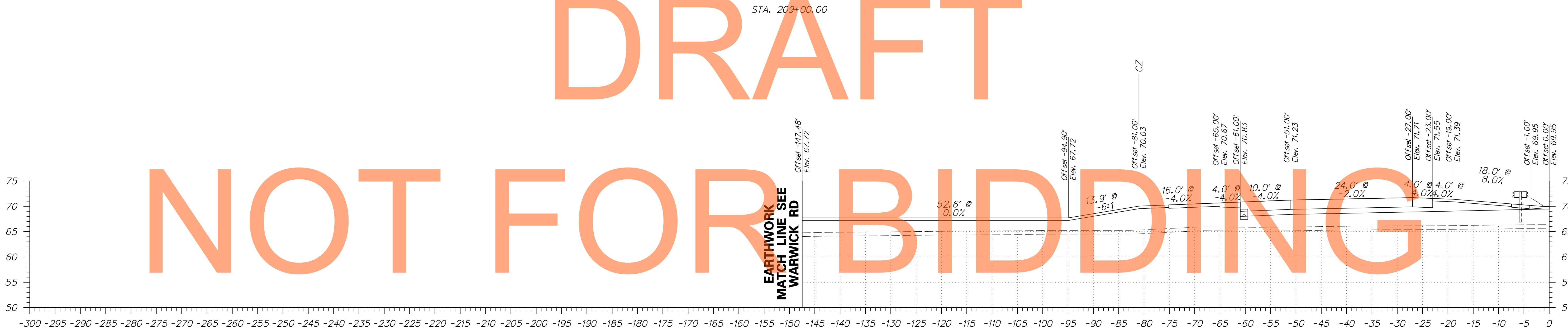
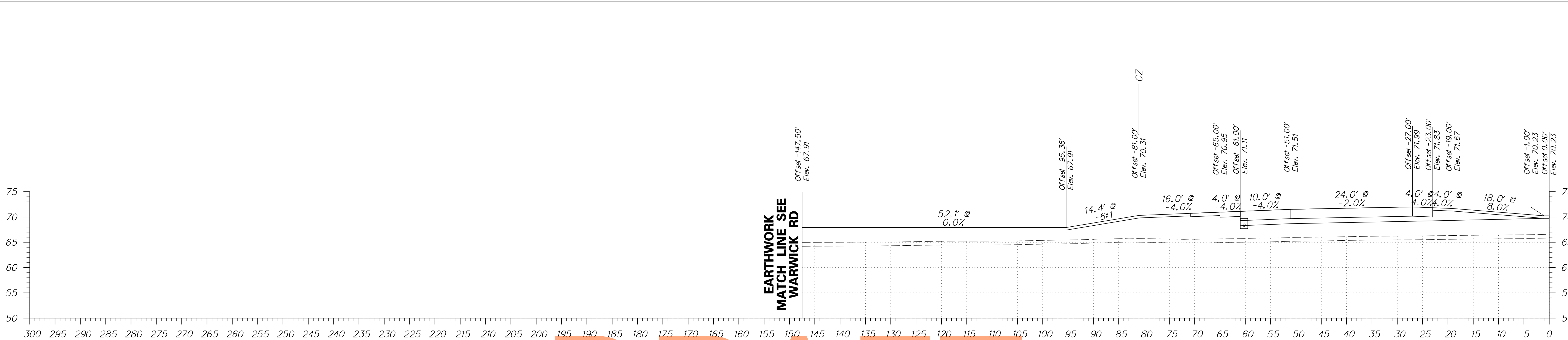

DRAFT  
NOT FOR BIDDING  
AUGUST 2015

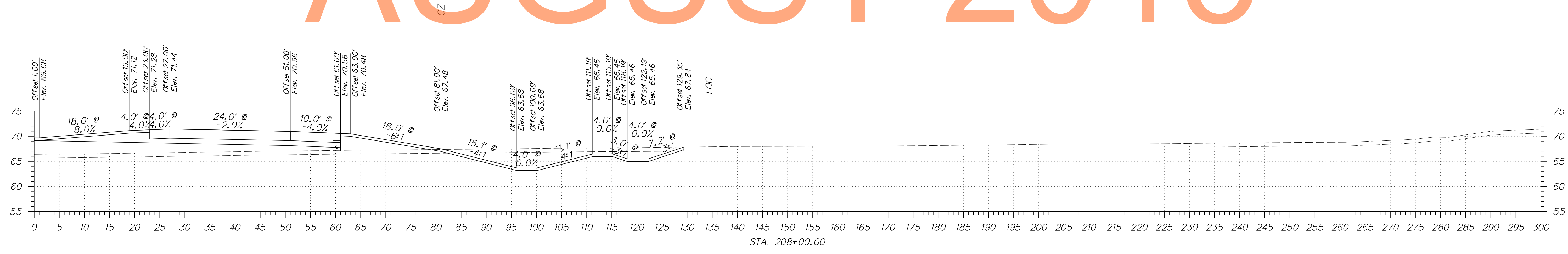
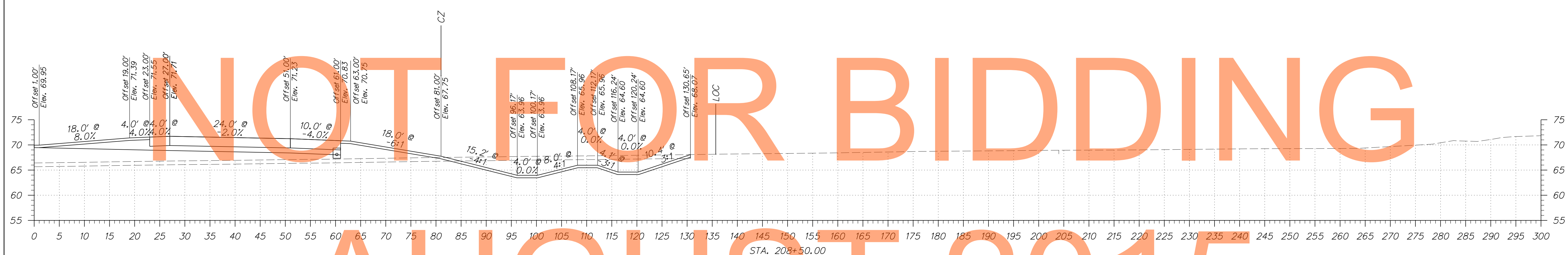
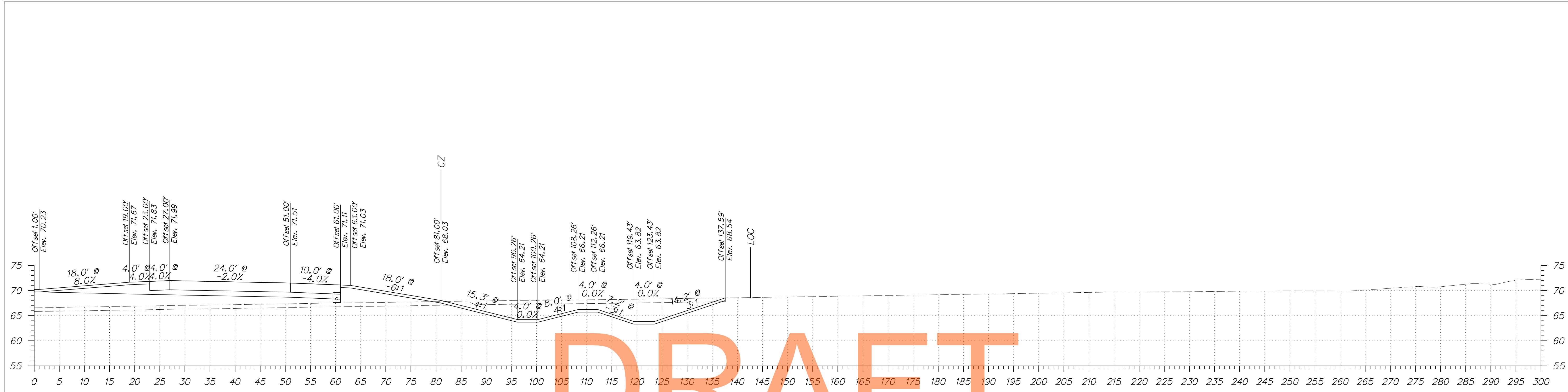

DRAFT

NOT FOR BIDDING

AUGUST 2015

ADDENDUMS / REVISIONS	

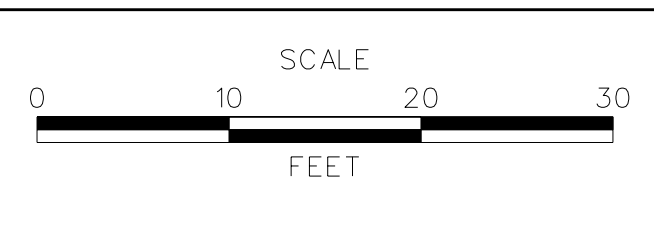

CONTRACT T200811301	BRIDGE NO.
COUNTY NEW CASTLE	DESIGNED BY: SL
	CHECKED BY: RK



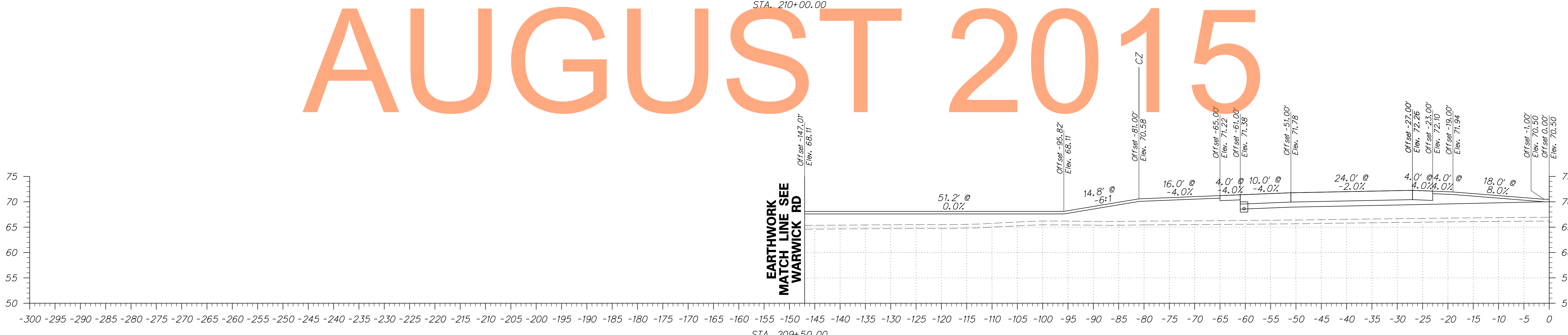
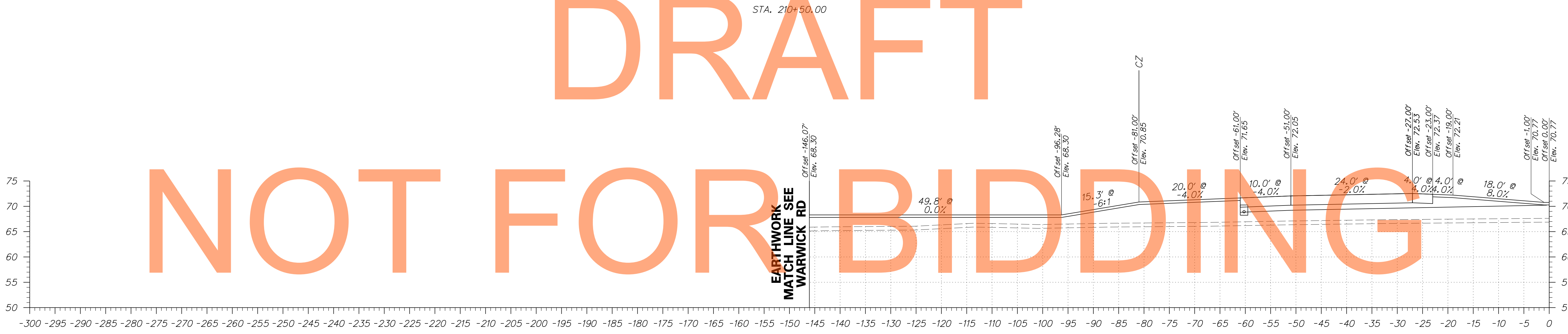
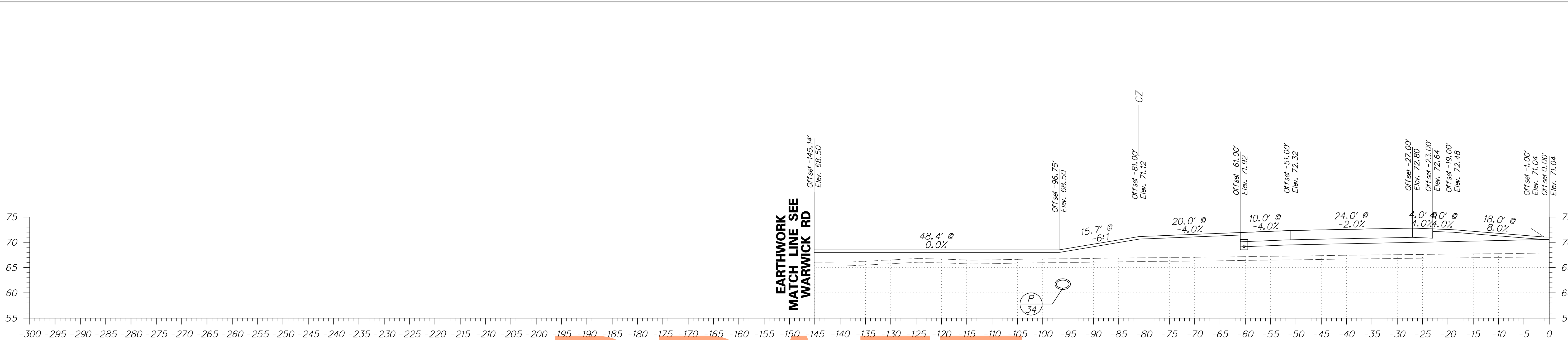

DRAFT

NOT FOR BIDDING

AUGUST 2015

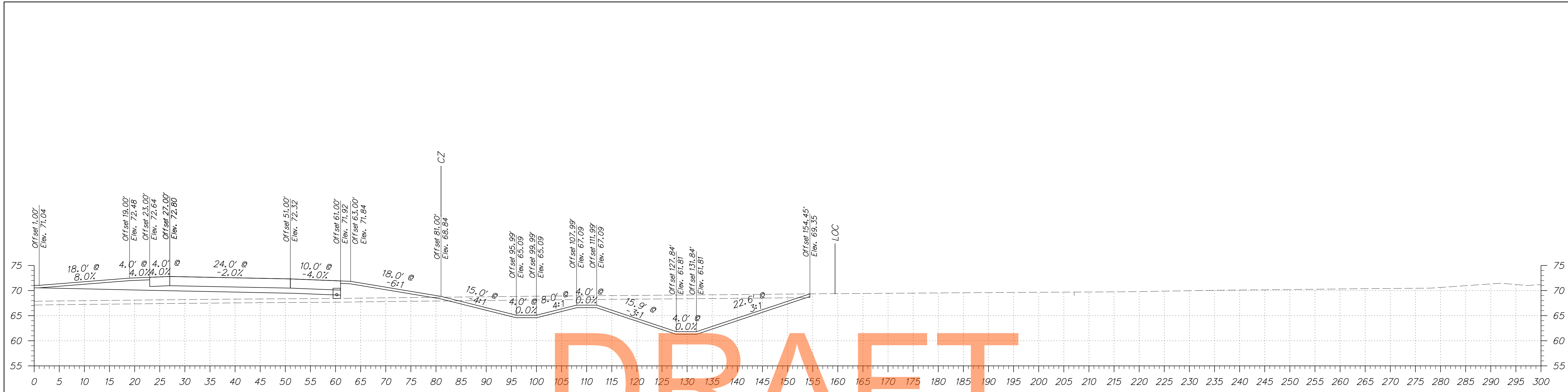

DRAFT

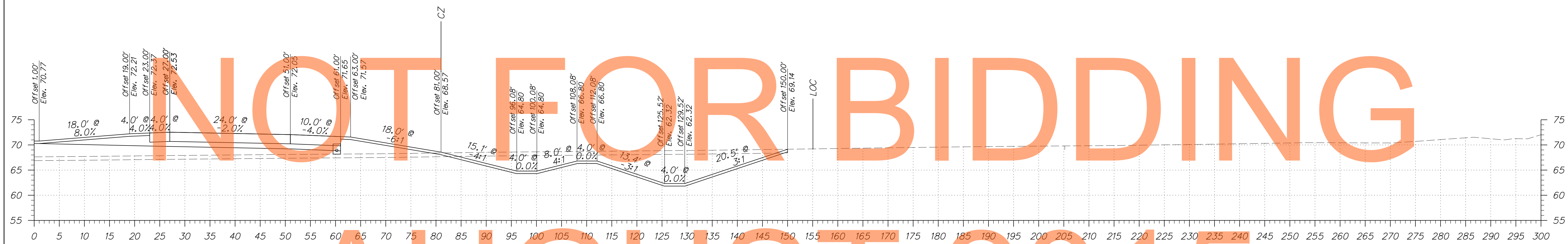

AUGUST 2015

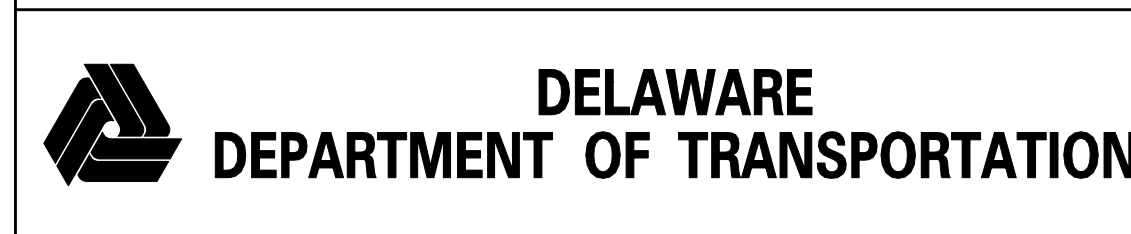
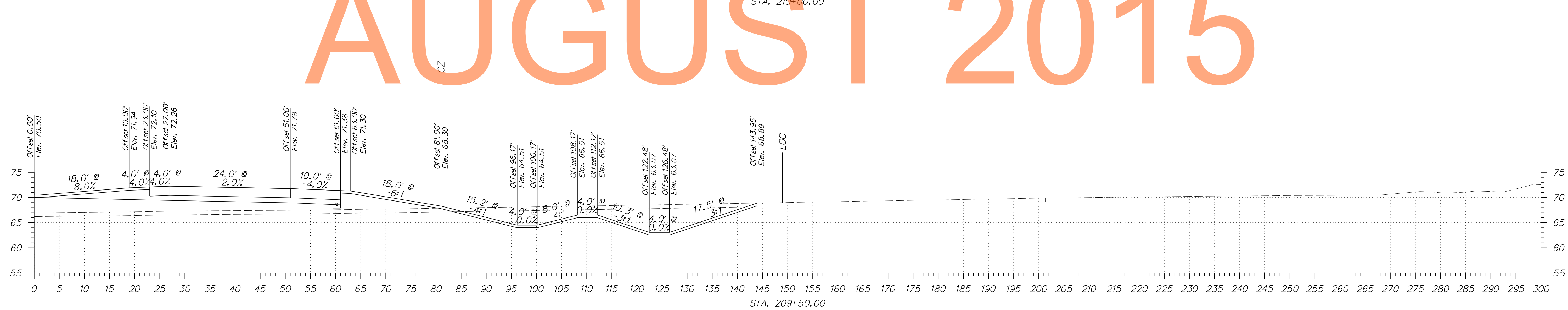

ADDENDUMS / REVISIONS	

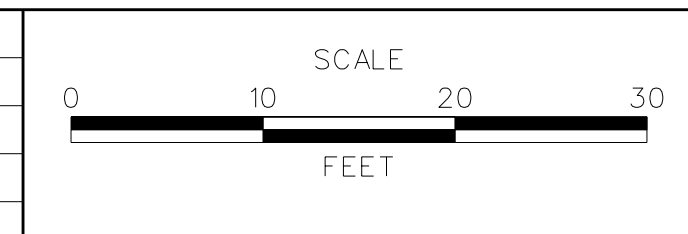

US 301  
MARYLAND STATE LINE  
TO LEVELS ROAD

CONTRACT T200811301	BRIDGE NO.
COUNTY NEW CASTLE	DESIGNED BY: SL CHECKED BY: RK

CROSS SECTIONS US 301 MAINLINE	SHEET NO. 98
	TOTAL SHTS. 539

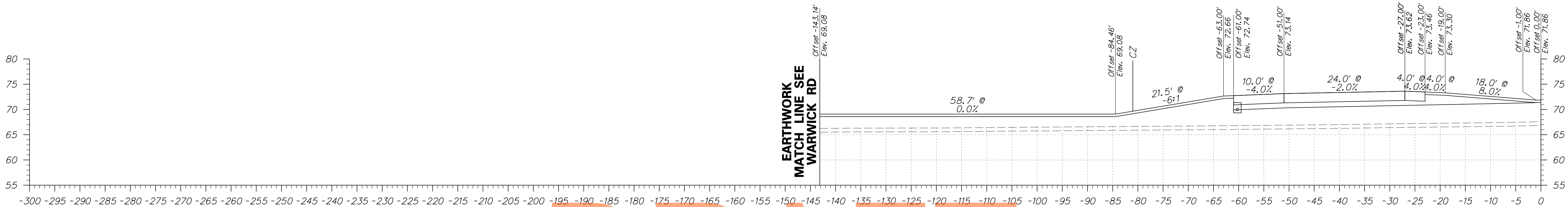

DRAFT

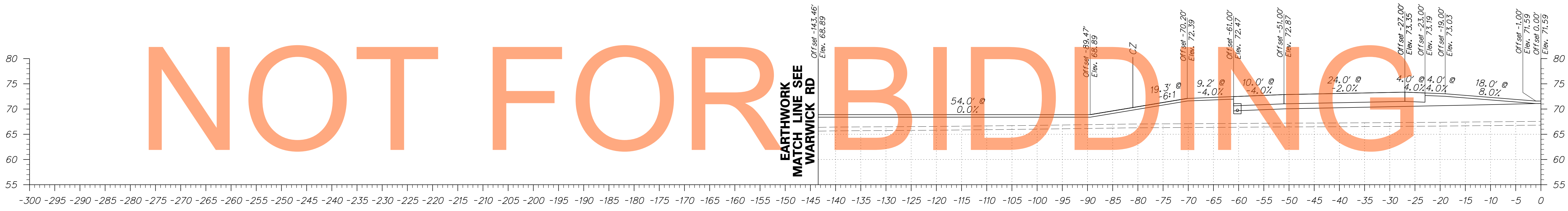

AUGUST 2015

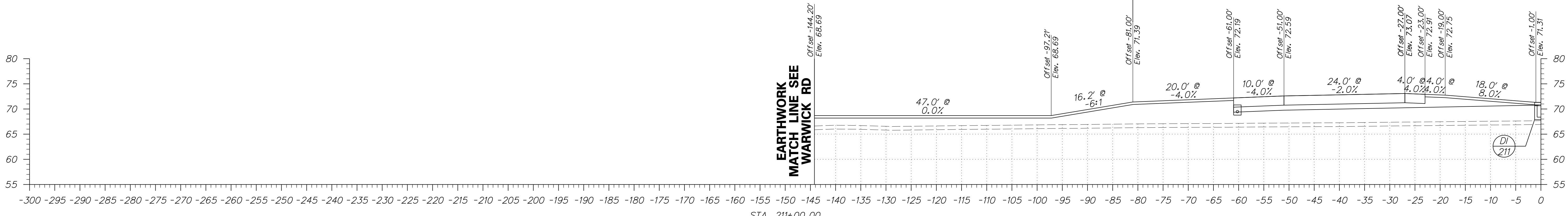

ADDENDUMS / REVISIONS	

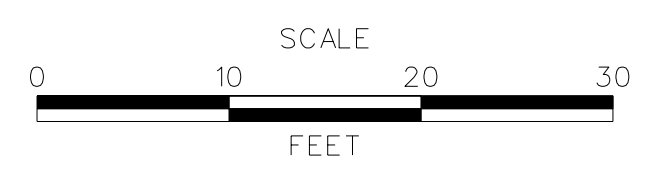

**US 301  
 MARYLAND STATE LINE  
 TO LEVELS ROAD**

CONTRACT T200811301	BRIDGE NO.
COUNTY NEW CASTLE	DESIGNED BY: SL CHECKED BY: RK

**CROSS SECTIONS  
 US 301 MAINLINE**

SHEET NO. 99
TOTAL SHTS. 539

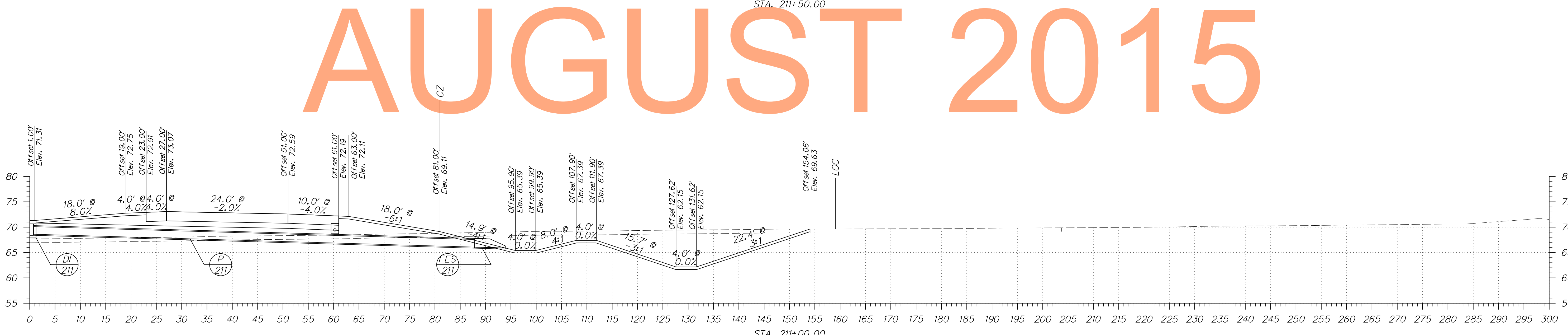
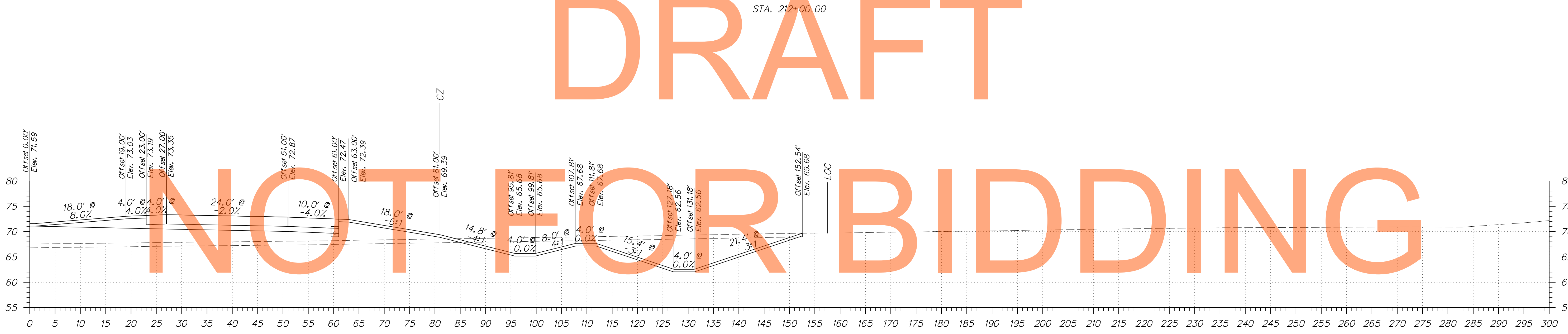
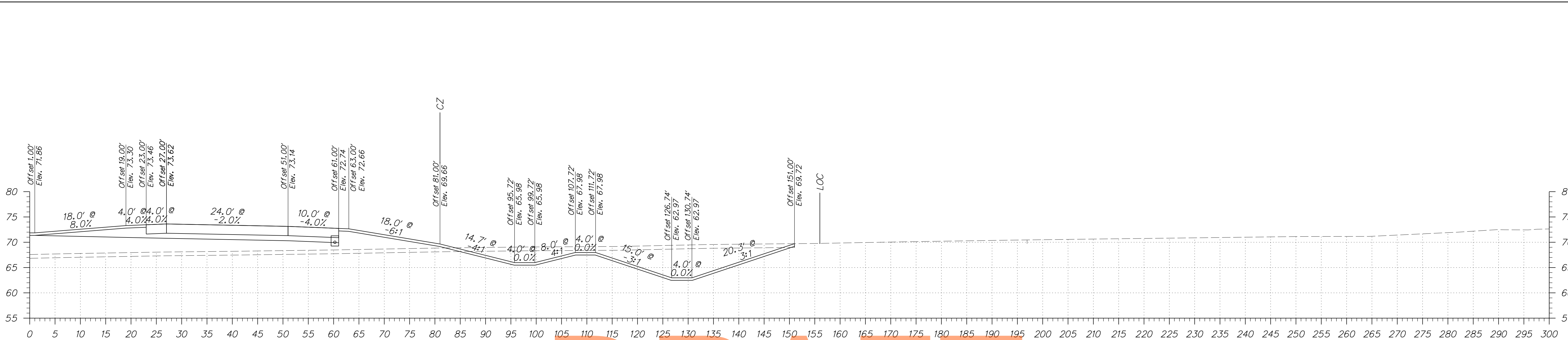

DRAFT  
NOT FOR BIDDING  
AUGUST 2015